



CITY OF DINUBA

PLANNING & DEVELOPMENT

1088 KAMM AVE.
DINUBA, CA 93618
(559) 591-5921

PUBLIC IMPROVEMENT STANDARDS

■ 2023 ■



TABLE OF CONTENTS

SECTION

CITY IMPROVEMENTS 1

<u>DRAWING NO.</u>	<u>TITLE</u>
C - 1	VALLEY GUTTER - CURB RETURN
C - 2	ALLEY - VALLEY GUTTER
C - 3	CURB RAMP (1 OF 2)
C - 4	CURB RAMP (2 OF 2)
C - 5	MEDIAN CURB
C - 6	DECORATIVE CURB, GUTTER & SIDEWALK
C - 7	SIDEWALK UNDERDRAIN PIPE - EXISTING CURB AND GUTTER
C - 8	SIDEWALK UNDERDRAIN PIPE
C - 9	CURB, GUTTER & SIDEWALK
C - 10	ROLL TYPE CURB & GUTTER
C - 11	RESIDENTIAL DRIVE APPROACH
C - 12	COMMERCIAL DRIVE APPROACH
C - 13	TYPICAL DRIVE APPROACH LOCATION
C - 14	EXISTING CURB REMOVAL

ELECTRICAL IMPROVEMENTS 2

<u>DRAWING NO.</u>	<u>TITLE</u>
E - 1	STREETLIGHT
E - 2	DECORATIVE STREETLIGHT
E - 3	SOLAR STREETLIGHT
E - 4	STREETLIGHT CONCRETE PULL BOXES
E - 5	STREETLIGHT POLE NUMBERING
E - 6	STREETLIGHT PLACEMENT - CUL-DE-SACS
E - 7	STREETLIGHT PLACEMENT - LOCAL STREET
E - 8	STREETLIGHT PLACEMENT - COLLECTOR STREET
E - 9	STREETLIGHT PLACEMENT - DIVIDED ARTERIAL STREETS

LANDSCAPE IMPROVEMENTS 3

<u>DRAWING NO.</u>	<u>TITLE</u>
L - 1	LANDSCAPE DESIGN & CONSTRUCTION STANDARDS
L - 2	LANDSCAPE DESIGN & CONSTRUCTION STANDARDS
L - 3	LANDSCAPE DESIGN & CONSTRUCTION STANDARDS
L - 4	WALL MOUNTED CONTROLLER
L - 5	WALL MOUNTED CONTROLLER - INTERIOR
L - 6	DRIP FLUSH INDICATOR
L - 7	MAINLINE POINT OF CONNECTION (POC) FILTER
L - 8	1" BASKET DRIP FILTER/PRESSURE REGULATOR
L - 9	GROUNDING PLATE AND LIGHTNING ARRESTOR
L - 10	BUBBLER/EMITTER ON ROOT BALL LAYOUT

TABLE OF CONTENTS

SECTION

LANDSCAPE IMPROVEMENTS 3

<u>DRAWING NO.</u>	<u>TITLE</u>
L - 11	BUBBLERS/EMITTERS ON ROOT BALL
L - 12	POP UP SPRAY HEAD ON SLOPE
L - 13	ROTOR SPRAY HEAD ON SLOPE
L - 14	POP UP SPRAY HEAD
L - 15	ROTOR SPRAY HEAD
L - 16	IRRIGATION TRENCHING
L - 17	PIPE AT PAVEMENT
L - 18	VALVE BOX LAYOUT
L - 19	SPLICE BOX
L - 20	WATER HAMMER ARRESTOR
L - 21	MAINLINE STUB OUT
L - 22	HYDROMETER
L - 23	MASTER VALVE
L - 24	QUICK COUPLER VALVE
L - 25	MASTER VALVE & FLOW SENSOR LAYOUT
L - 26	FLOW SENSOR
L - 27	GATE VALVE AND ANCHOR
L - 28	2-WIRE IRRIGATION CONNECTIONS
L - 29	2-WIRE REMOTE CONTROL VALVE
L - 30	HYDROMETER LAYOUT
L - 31	1" AIR RELEASE VALVE
L - 32	8" CONCRETE MOW STRIP
L - 33	ROOT BALL SHAVING
L - 34	CROWN OBSERVATION - MULTI
L - 35	CROWN OBSERVATION - HIGH BRANCHED
L - 36	ROOT OBSERVATION - CONTAINER
L - 37	GROUND COVER
L - 38	SHRUB - UNMODIFIED SOIL
L - 39	SHRUB ON SLOPE (5% TO 50%)
L - 40	TREE WITH BERM
L - 41	TREE ON SLOPE (5% TO 50%)
L - 42	VINE - UNMODIFIED SOIL
L - 43	TREE STAKING - SINGLE METAL STAKE
L - 44	TREE PROTECTION
L - 45	WATERING MATURE TREES
L - 46	LINEAR ROOT BARRIERS - PARKING LOT ISLANDS
L - 47	LINEAR ROOT BARRIERS

TABLE OF CONTENTS

SECTION

MISCELLANEOUS IMPROVEMENTS 4

<u>DRAWING NO.</u>	<u>TITLE</u>
M - 1	GALVANIZED STEEL BOLLARD
M - 2	TYPICAL FIRE HYDRANT BOLLARD LOCATION
M - 3	TRASH BIN BLOCK ENCLOSURE
M - 4	TRASH ENCLOSURE GATE DETAIL
M - 5	CHAIN LINK FENCE DETAIL
M - 6	ELEVATION BENCHMARK DETAILS
M - 7	PROPERTY MONUMENT DETAILS
M - 8	TYPICAL PARKING LOT DESIGN & LANDSCAPE
M - 9	ACCESSIBLE PARKING
M - 10	ACCESSIBLE PARKING SIGN
M - 11	INTERNATIONAL SYMBOL OF ACCESSIBILITY (ISA) INSTALLATION
M - 12	MASONRY BLOCK WALL/FENCE
M - 13	PIPE SUPPORTS ACROSS TRENCHES
M - 14	SHALLOW PIPE BACKFILL
M - 15	TYPICAL LOT DRAINAGE WITH PARK STRIPS SHOWN
M - 16	SATELLITE ASSEMBLY (CONTROLLER)
M - 17	LOT LINE GRADING STANDARD
M - 18	WHEEL STOP

SECTION

STREET IMPROVEMENTS 5

<u>DRAWING NO.</u>	<u>TITLE</u>
P - 1	PARKING LOT PAVEMENT STANDARDS
P - 2	STREET CROSS-SECTION
P - 3	STREET WITH MEDIAN CROSS-SECTION
P - 4	TYPICAL COMMERCIAL, INDUSTRIAL, AND RESIDENTIAL CUL-DE-SAC
P - 5	STREET KNUCKLE CONNECTIONS
P - 6	CROSSWALK MARKINGS
P - 7	STOP BAR MARKING AND STOP SIGNS LOCATION
P - 8	STREET SIGN STANDARD (1 OF 2)
P - 9	STREET SIGN INSTALLATION (2 OF 2)
P - 10	TYPE-A STREET INTERSECTION & CURVE RADIUS SURVEY MONUMENT
P - 11	TIMBER BARRICADE
P - 12	STREET NAME SIGN LOCATION
P - 13	DECORATIVE CONCRETE MEDIAN

TABLE OF CONTENTS

SECTION

STORM DRAIN SYSTEM

6

<u>DRAWING NO.</u>	<u>TITLE</u>
SD - 1	TYPE 'A' CATCH BASIN 42" CURB INLET AND 42" BASIN
SD - 2	TYPE 'B' CATCH BASIN 48" CURB INLET AND 48" X 36" BASIN
SD - 3	TYPE 'C' CATCH BASIN 24" DIAMETER INLET DRAIN PIPE
SD - 4	TYPE 'D' CATCH BASIN STANDARD FLAT GRATE
SD - 5	DOUBLE TYPE 'D' INLET (SHEET 1 OF 2)
SD - 6	DOUBLE TYPE 'D' INLET (SHEET 2 OF 2)
SD - 7	TYPE 'E' INLET - TEMPORARY WITH CURB FACE OPENING
SD - 8	TYPE 'E' & 'G' 7' CURB INLET
SD - 9	TYPE 'E' & 'G' INLET OPENING DETAIL
SD - 10	MANHOLE FRAME AND COVER FOR TYPE 'E' & 'G' INLET
SD - 11	STORM DRAIN MANHOLE
SD - 12	CATCH BASIN GRATE
SD - 13	"CHRISTY" U SERIES CATCH BASINS
SD - 14	TOP EDGE CHOICES FOR CATCH BASIN AND/OR GRATE RING
SD - 15	OUTFALL STRUCTURE TYPE 'A'
SD - 16	FENCE CAGE FOR OUTFALL STRUCTURE TYPE 'A'
SD - 17	DESIGN TABLE FOR OUTFALL STRUCTURE TYPE 'A'
SD - 18	OUTFALL STRUCTURE TYPE 'B'
SD - 19	OUTFALL STRUCTURE TYPE 'B' REINFORCEMENT DETAILS
SD - 20	FENCE CAGE FOR OUTFALL STRUCTURE TYPE 'B'
SD - 21	DESIGN TABLE FOR OUTFALL STRUCTURE TYPE 'B'

SECTION

SANITARY SEWER SYSTEM

7

<u>DRAWING NO.</u>	<u>TITLE</u>
SS - 1	SEWER AND WATER SERVICE PROPERTY LOCATIONS
SS - 2	WATER MAIN AND SANITARY SEWER MAIN SEPARATION (SHEET 1 OF 2)
SS - 3	WATER MAIN AND SANITARY SEWER MAIN SEPARATION (SHEET 2 OF 2)
SS - 4	INVERT PLANS OF STANDARD MANHOLES
SS - 5	SANITARY SEWER MANHOLE
SS - 6	SANITARY SEWER DROP MANHOLE
SS - 7	SANITARY SEWER DROP MANHOLE - CLAMPING BRACKET
SS - 8	SEWER LATERALS
SS - 9	MANHOLE FRAME AND COVER
SS - 10	SEWER CLEANOUT
SS - 11	ECCENTRIC MANHOLE
SS - 12	COMMERCIAL AND INDUSTRIAL GREASE TRAP
SS - 13	SEWER LATERAL SERVICE CONNECTION INTO EXISTING SEWER MAIN

TABLE OF CONTENTS

SECTION

WATER SYSTEM

8

<u>DRAWING NO.</u>	<u>TITLE</u>
W - 1	EXISTING WELL ABANDONMENT
W - 2	WATER BLOW-OFF
W - 3	THRUST BLOCK
W - 4	BACKFLOW DEVICE AND FIRE DEPARTMENT CONNECTION
W - 5	FIRE HYDRANT INSTALLATION
W - 6	FIRE HYDRANT PAVEMENT MARKER LOCATION
W - 7	FIRE HYDRANT LOCATION - SIDEWALK
W - 8	WATER VALVE, WELL, AND COVER
W - 9	1" RESIDENTIAL WATER SERVICE
W - 10	1.5" & 2" RESIDENTIAL WATER SERVICE
W - 11	COMMERCIAL 3-MANIFOLD WATER SERVICE
W - 12	2" COMMERCIAL WATER SERVICE
W - 13	4" TURBO WATER SERVICE
W - 14	6" TURBO WATER SERVICE
W - 15	3/4" TO 2" REDUCED PRESSURE PRINCIPAL BACKFLOW PREVENTERS
W - 16	WATER VALVE
W - 17	TRENCH DETAIL
W - 18	WATER SAMPLE STATION (SHEET 1 OF 2)
W - 19	WATER SAMPLE STATION (SHEET 2 OF 2)
W - 20	PRESSURE VACUUM BREAKER BACKFLOW PREVENTER INSTALLATION
W - 21	COMPOUND OR TURBINE METER SETTING WITH REDUCED PRESSURE DEVICE
W - 22	DOUBLE CHECK VALVE
W - 23	APPROVED PORTABLE WATER TRANSPORT BACKFLOW PROTECTION
W - 24	EQUIPMENT COVERS
W - 25	WATER MAIN INTERSECTION CONNECTIONS
W - 26	LOCATIONS OF UTILITY MAINS
W - 27	LOCATIONS FOR UNDERGROUND CONDUITS & PIPES IN RESIDENTIAL AREA CITY STREETS

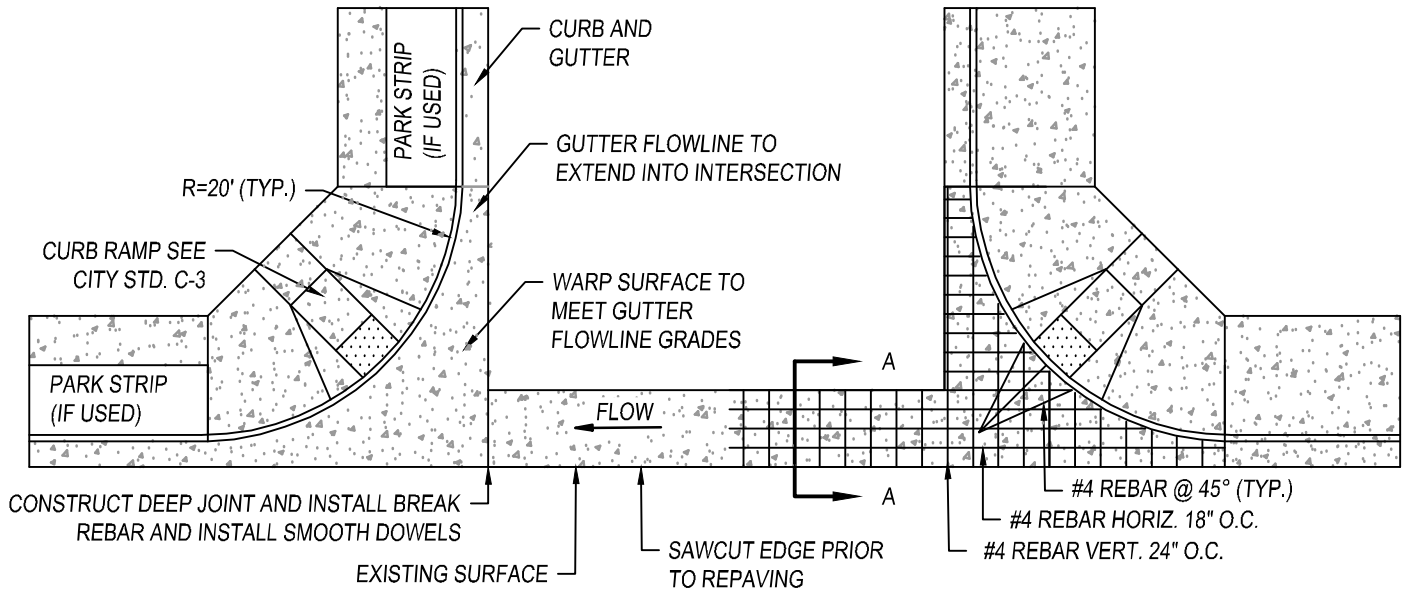

PLAN VIEW

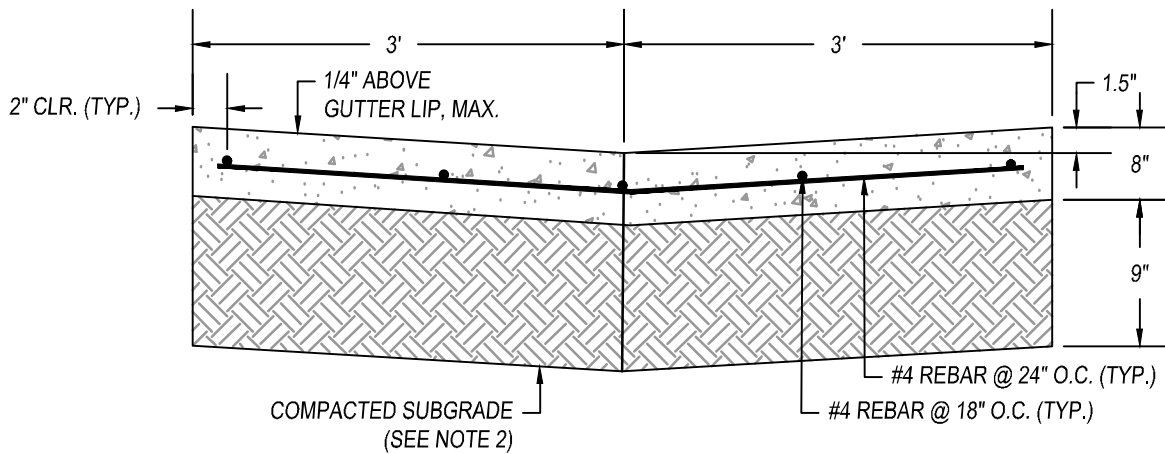

SECTION A-A

NOTES:

1. VALLEY GUTTER SHALL BE CLASS "3" CONCRETE (6 SACK MINIMUM).
2. COMPACT SUBGRADE TO 95% RELATIVE COMPACTION, PER ASTM D1557 AND TEST METHOD CAL216.
3. WIDER CROSS GUTTER MAY BE REQUIRED, AS DIRECTED BY THE CITY ENGINEER.
4. THE VALLEY GUTTER SHALL HAVE A MINIMUM SLOPE OF 0.003 IN THE DIRECTION OF FLOW.
5. ALL WORK SHALL CONFORM TO THE APPLICABLE SECTIONS OF THE SPECIFICATIONS ENTITLED "STANDARD SPECIFICATIONS, STATE OF CALIFORNIA, DEPARTMENT OF TRANSPORTATION", APPROVED CURRENT EDITION.
6. EXPANSION JOINTS SHALL BE CONSTRUCTED AT EVERY 30' OR AS DIRECTED BY THE CITY ENGINEER.
7. AN ENCROACHMENT PERMIT IS REQUIRED FOR ALL WORK DONE WITHIN THE CITY OF DINUBA RIGHT OF WAY.
8. BEARING SOIL SHALL BE COMPACTED TO 95% RELATIVE COMPACTION AS DETERMINED BY A.S.T.M. D-1557 TO A DEPTH OF 1.0' BELOW CROSS GUTTERS.
9. ALL CROSS GUTTER LOCATIONS AND SIZES ARE TO BE APPROVED BY THE CITY ENGINEER.



CITY COUNCIL APPROVAL: 01/24/2023
 APPROVED BY CITY ENGINEER
 APPROVED BY PUBLIC WORKS DIRECTOR

**VALLEY GUTTER -
CURB RETURN**

PUBLIC IMPROVEMENT STANDARDS

C-1

REVISIONS

NAME	BY	DATE

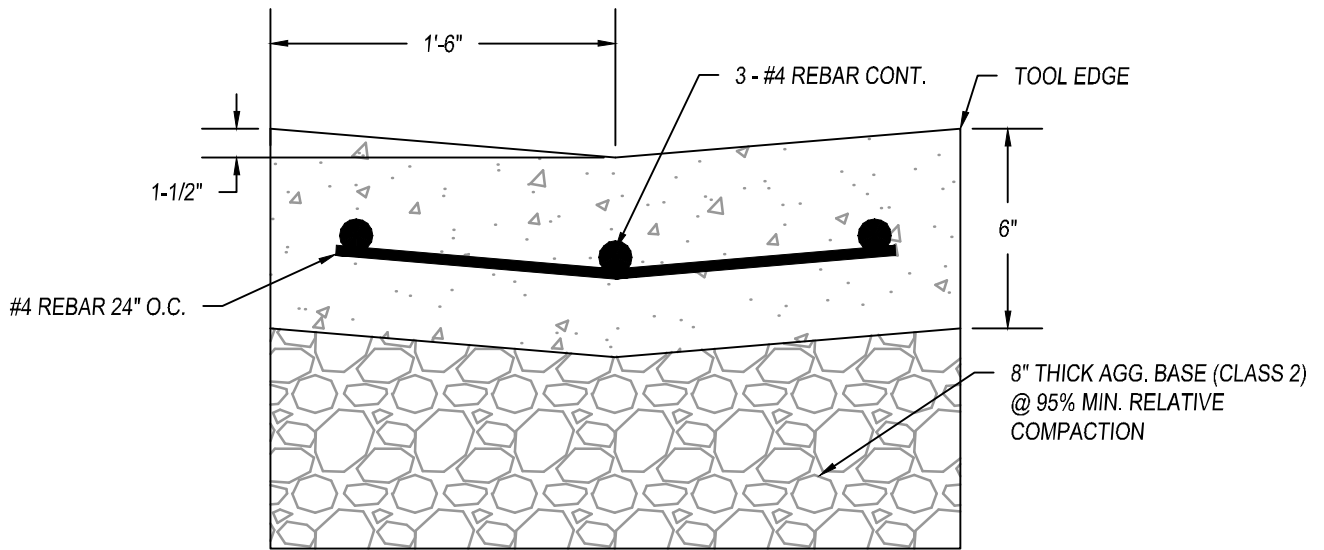

VALLEY GUTTER CROSS -SECTION

NOTES:

1. CONCRETE SHALL BE TYPE "A" (6 SACK MINIMUM)
2. REBAR SHALL HAVE A MINIMUM OF 2" OF CLEAR COVERAGE



CITY COUNCIL APPROVAL: 01/24/2023
 APPROVED BY CITY ENGINEER
 APPROVED BY PUBLIC WORKS DIRECTOR

ALLEY - VALLEY GUTTER

PUBLIC IMPROVEMENT STANDARDS

C-2

REVISIONS

NAME	BY	DATE

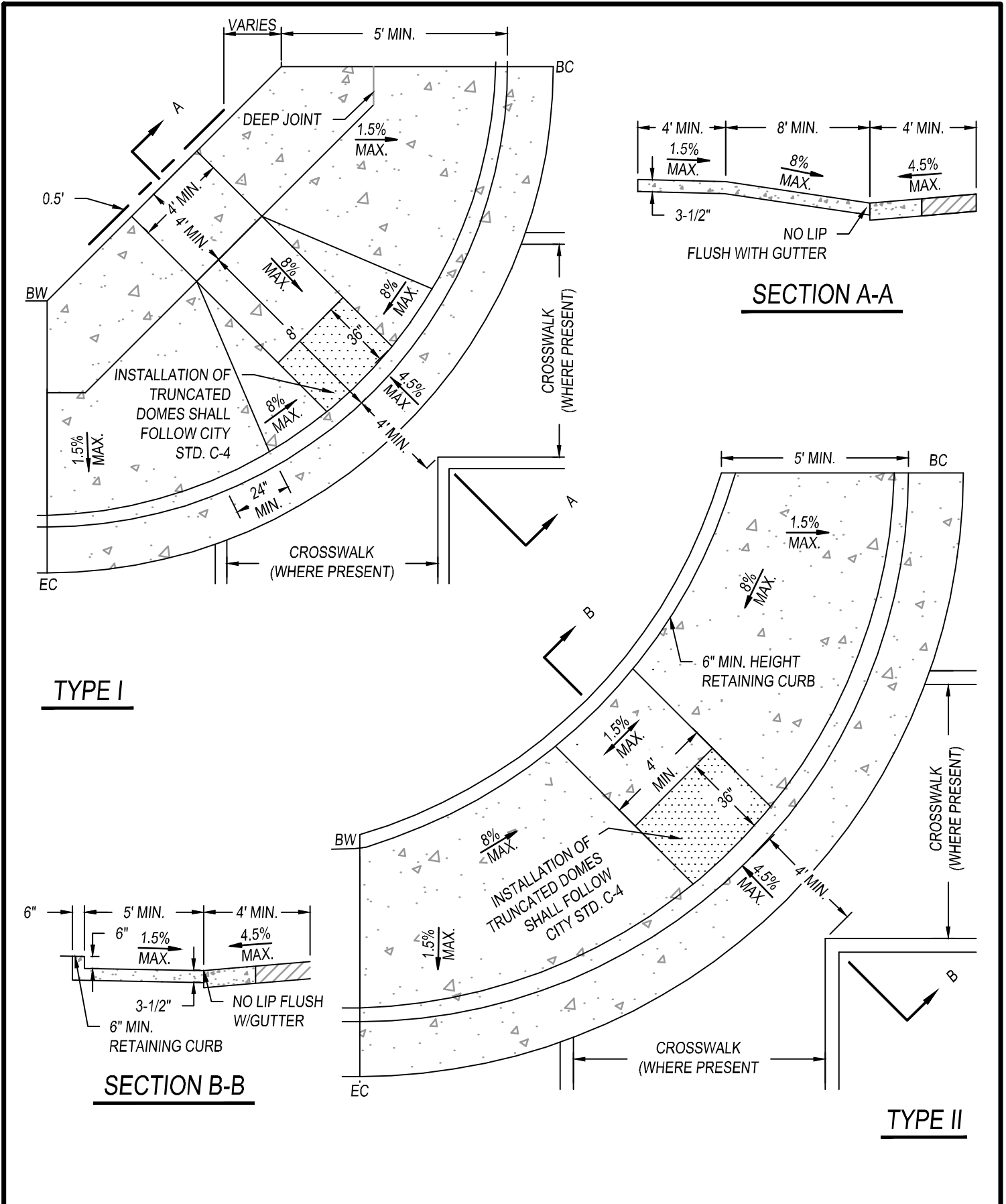

CITY COUNCIL APPROVAL: 01/24/2023

APPROVED BY CITY ENGINEER

APPROVED BY PUBLIC WORKS DIRECTOR

CURB RAMP (1 OF 2)

PUBLIC IMPROVEMENT STANDARDS

C-3

REVISIONS		
NAME	BY	DATE

DETECTABLE WARNING NOTES

1. RAMP SHALL HAVE A DETECTABLE WARNING THAT EXTENDS 36" IN THE DIRECTION OF TRAVEL AND EXTENDS THE FULL WIDTH OF THE RAMP, EXCLUDING FLARED SIDES, INSIDE THE RAMP BORDER.
2. DETECTABLE WARNINGS SHALL COMPLY WITH THE CURRENT EDITION OF THE CALIFORNIA BUILDING CODE.
3. DETECTABLE WARNINGS SHALL BE SLIP-RESISTANT AND CONSIST OF RAISED TRUNCATED DOMES.
4. THE DETECTABLE WARNING SHALL CONTRAST VISUALLY WITH ADJOINING SURFACES, EITHER LIGHT-ON-DARK OR DARK-ON-LIGHT. THE MATERIAL USED TO PROVIDE CONTRAST SHALL BE AN INTEGRAL PART OF THE WALKING SURFACE. DETECTABLE WARNING SURFACES SHALL BE YELLOW AND APPROXIMATE 33538 OF SAE AMS-STD-595A.
5. THE TRUNCATED DOMES MAY BE CONSTRUCTED IN A VARIETY OF METHODS, INCLUDING CAST-IN-PLACE OR STAMPED, OR MAY BE A PART OF A PREFABRICATED SURFACE TREATMENT.
6. DETECTABLE WARNING SURFACES AT LOCATIONS OTHER THAN CURB RAMPS, ISLANDS, OR CUT-THROUGH MEDIANS SHALL DIFFER FROM ADJOINING SURFACES IN RESILIENCY OR SOUND-ON-CANE CONTACT
7. WHERE INSTALLED IN A RADIAL PATTERN, TRUNCATED DOMES SHALL HAVE A CENTER-TO-CENTER SPACING OF 1.6"-2.4".

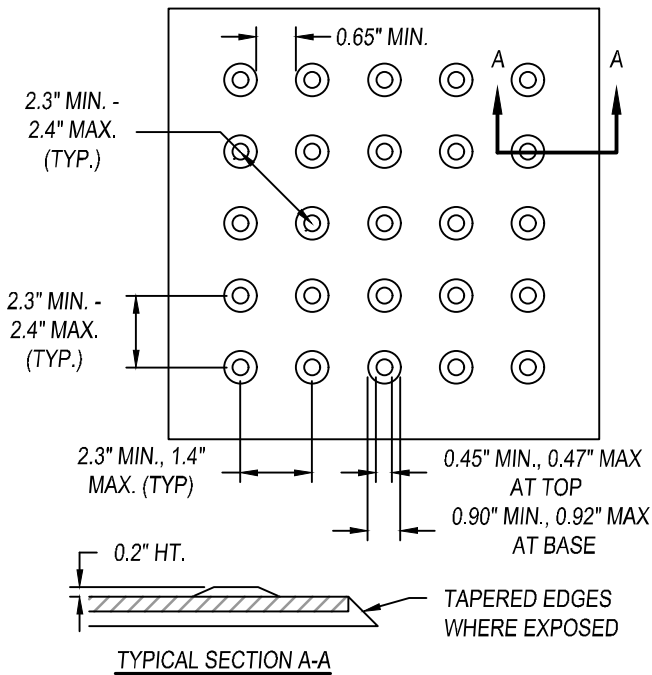

DETECTABLE WARNING DETAIL

NOTES:

1. RAMP SHALL BE A MINIMUM OF 4' WIDE AND SHALL LIE, GENERALLY, IN A SINGLE SLOPED PLANE WITH A MINIMUM OF SURFACE WARPING AND CROSS SLOPE.
2. RAMP SLOPE SHALL NOT EXCEED 8%. FOR TYPE I RAMPS, THE SLOPE OF THE FLARED SIDES SHALL NOT EXCEED 8%.
3. TRANSITIONS FROM RAMPS AND LANDINGS TO SIDEWALKS, GUTTERS OR STREETS SHALL BE FLUSH AND FREE OF ABRUPT CHANGES.
4. THE SLOPE OF ADJOINING GUTTERS, ROAD SURFACE OR ACCESSIBLE ROUTE WITHIN 4' OF THE BOTTOM OF THE RAMP SHALL NOT EXCEED 4.5% SLOPE. THIS LANDING AREA SHALL BE THE FULL WIDTH OF THE RAMP. GUTTER PAN TRANSITIONING SHALL OCCUR OUTSIDE OF THIS LANDING AREA.
5. THE 4' CLEAR SPACE AT THE BOTTOM OF THE RAMP SHALL TERMINATE WITHIN THE INSIDE EDGE OF MARKED CROSSWALKS.
6. PROVIDE A LANDING AREA AT THE UPPER END OF THE RAMP OF AT LEAST 4' DEEP BY THE FULL WIDTH OF THE RAMP. THE UPPER LANDING AREA SHALL NOT EXCEED 1.5% SLOPE IN ANY DIRECTION.
7. SURFACE OF CURB RAMP AND FLARED SIDES SHALL HAVE A BROOM FINISH TRANSVERSE TO THE PATH OF TRAVEL AND SHALL BE OF CONTRASTING FINISH TO THAT OF ADJACENT SIDEWALK.
8. FOR TYPE I RAMPS, THERE SHALL BE A SEGMENT OF FULL-HEIGHT CURB AT LEAST 24" LONG ON EACH SIDE OF THE CURB RAMP AND WITHIN THE MARKED CROSSWALK.

CURB RAMP (2 OF 2)



CITY COUNCIL APPROVAL: 01/24/2023

APPROVED BY CITY ENGINEER

APPROVED BY PUBLIC WORKS DIRECTOR

PUBLIC IMPROVEMENT STANDARDS

C-4

REVISIONS

NAME	BY	DATE

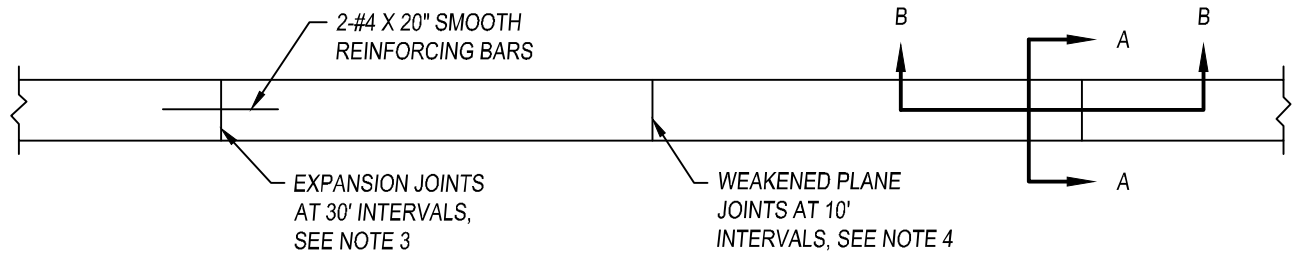

PLAN

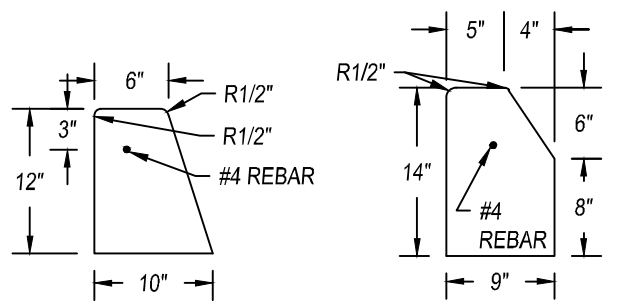

SECTION A-A

LANDSCAPE CURB

SECTION A-A

STATE STANDARD B-1 FOR CITY MEDIAN CURB

* MEDIAN CURBS SHALL HAVE 4" TOTAL BATTER

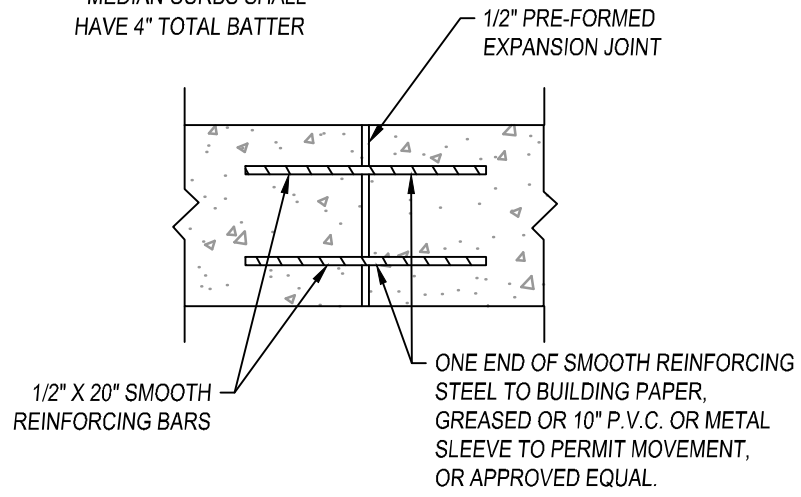

SECTION B-B

NOTES:

1. ALL CONCRETE WORK SHALL BE OF CLASS 'A' CONCRETE (6 SACK MIN.).
2. ALL CONCRETE SHALL HAVE A LIGHT BROOM FINISH.
3. EXPANSION JOINTS 1/2" WIDE SHALL BE INSTALLED IN CURB AT 30' INTERVALS, EXPANSION JOINTS FILLED SHALL BE SHAPED TO THE CROSS SECTION OF THE CURB, JOINTS SHALL BE CONSTRUCTED AT RIGHT ANGLES TO BACK OF CURB.
4. WEAKENED PLANE JOINTS SHALL BE A MINIMUM DEPTH OF 1-1/2" TO 2" MIN. WITH A SCORING TOOL LEAVING THE EDGES ROUNDED.



CITY COUNCIL APPROVAL: 01/24/2023

APPROVED BY CITY ENGINEER

APPROVED BY PUBLIC WORKS DIRECTOR

MEDIAN CURB

PUBLIC IMPROVEMENT STANDARDS

C-5		
REVISIONS		
NAME	BY	DATE

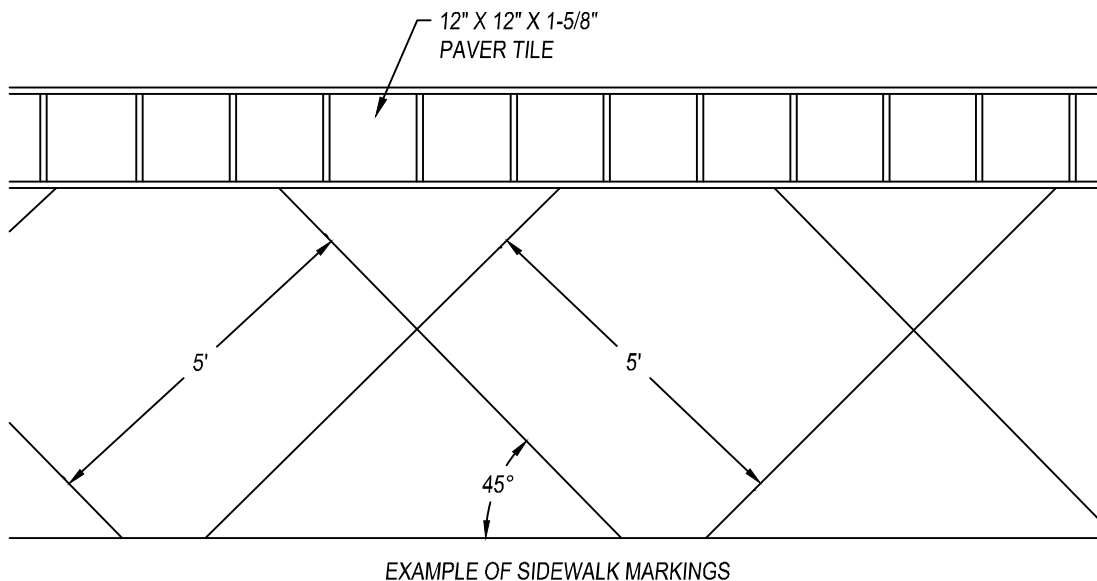
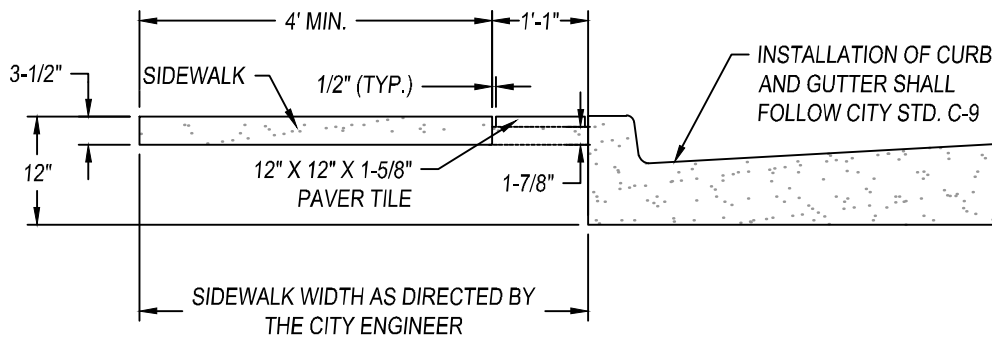

NOTES:

1. ALL DECORATIVE CURB, GUTTER AND SIDEWALK SHALL BE CLASS "A" CONCRETE (6 SACK MIN.) COLOR: SAN DIEGO BUFF, DAVIS BRAND COLOR, BUILDERS CONCRETE BATCH NO. NK60170, OR APPROVED EQUAL.
2. MARKINGS ARE 5' X 5', "SALT" WITH MEDIUM "BROOM" FINISH. SQUARE MARKINGS TO BE AT 45° ANGLES.
3. PAVER TILE COLOR: STEP STONE, CLASSIC WALKS, CUSTOM COLOR NO. 1144, FORM FINISH, OR APPROVED EQUAL.
4. PAVER MORTAR COLOR: NATURAL COLOR, OR APPROVED EQUAL.
5. CONCRETE SHALL CONFORM TO THE PROJECT PLANS AND SPECIFICATIONS AND TO THE STATE SPECIFICATIONS.



CITY COUNCIL APPROVAL: 01/24/2023
 [Signature]
 APPROVED BY CITY ENGINEER
 [Signature]
 APPROVED BY PUBLIC WORKS DIRECTOR

**DECORATIVE CURB,
 GUTTER & SIDEWALK**

PUBLIC IMPROVEMENT STANDARDS

C-6		
REVISIONS		
NAME	BY	DATE

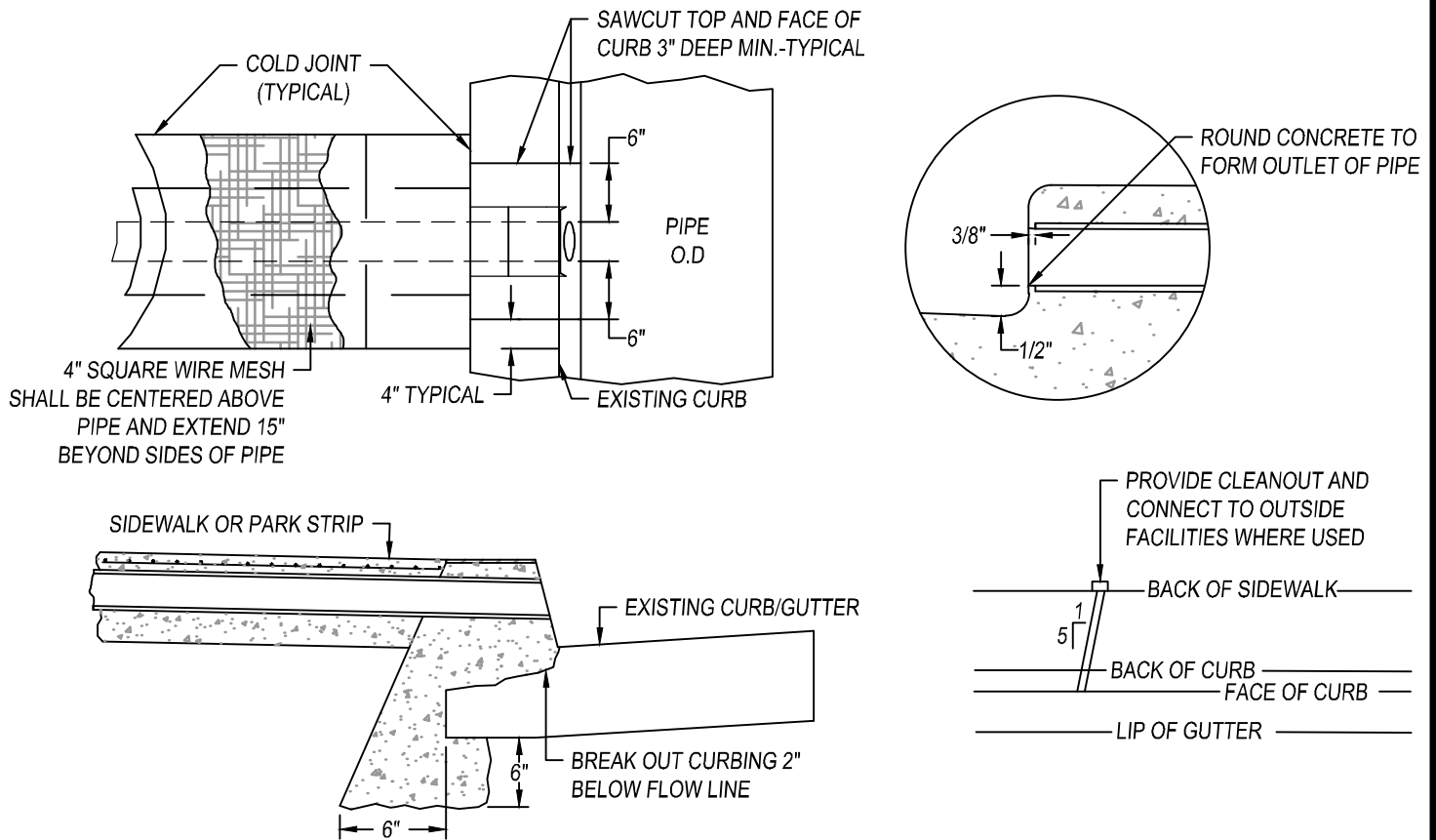

DRAINLINE INSTALLATION FOR EXISTING CURB AND GUTTER

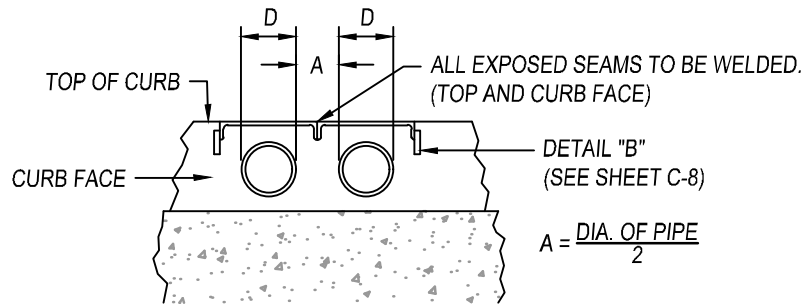

DUAL PIPE INSTALLATION

NOTES:

1. PIPE SHALL BE ONE CONTINUOUS LENGTH WITH NO JOINTS FROM PROPERTY LINE TO CURB LINE.
2. MULTIPLE PIPES TO BE SET A MINIMUM DISTANCE OF D/2 APART. (SEE DETAIL ABOVE)
3. CONCRETE SHALL BE CLASS "A" CONCRETE (6 SACK MIN.)
4. PIPE SHALL BE SCH. 80 PVC.
5. WIRE MESH TO BE INSTALLED IN CONCRETE ABOVE DRAIN LINE.
6. PERMITTED SIZE AND NUMBER OF PIPES/TUBING TO BE BASED ON DRAINAGE AREA AND SHALL BE DETERMINE BY THE ENGINEER OF RECORD.
7. NO DRAIN ALL BE PERMITTED IN DRIVE APPROACH AREAS.
8. DRAINS SHALL BE ANGLED THROUGH SIDEWALK IN DIRECTION OF GUTTER FLOW.



CITY COUNCIL APPROVAL: 01/24/2023

APPROVED BY CITY ENGINEER

APPROVED BY PUBLIC WORKS DIRECTOR

**SIDEWALK UNDERDRAIN PIPE -
EXISTING CURB AND GUTTER**

PUBLIC IMPROVEMENT STANDARDS

C-7		
REVISIONS		
NAME	BY	DATE

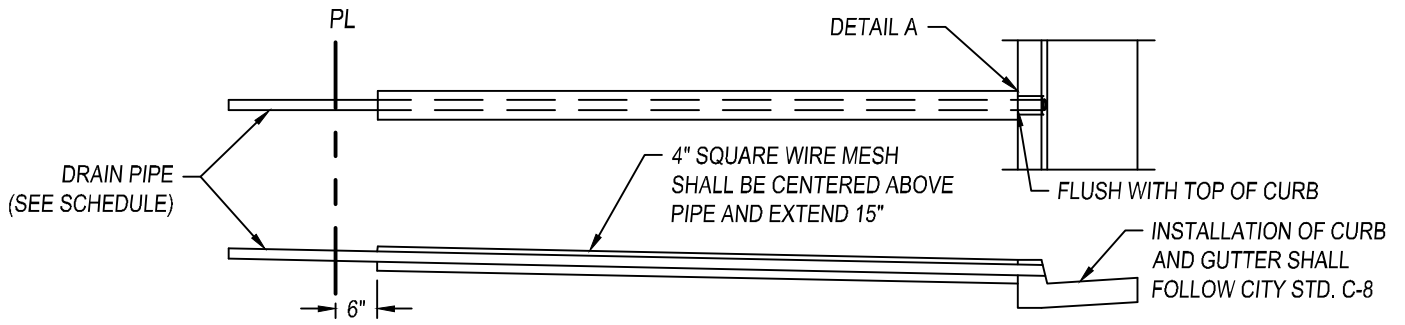

DRAINLINE INSTALLATION FOR NEW CONSTRUCTION

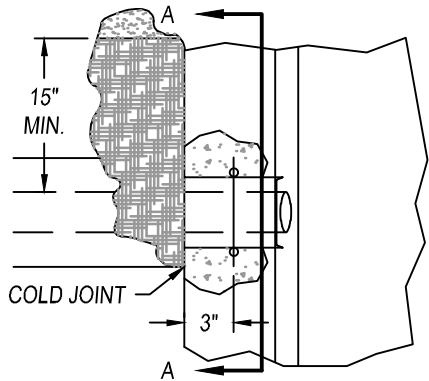

DETAIL A

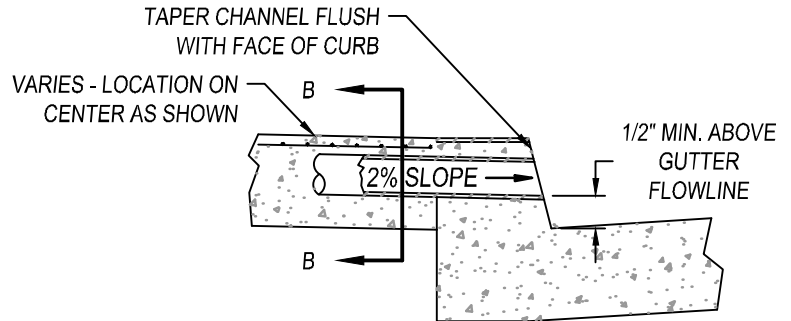

DETAIL B

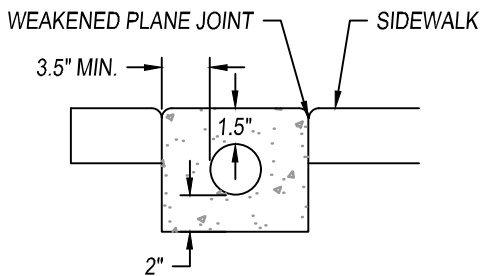

SECTION A-A

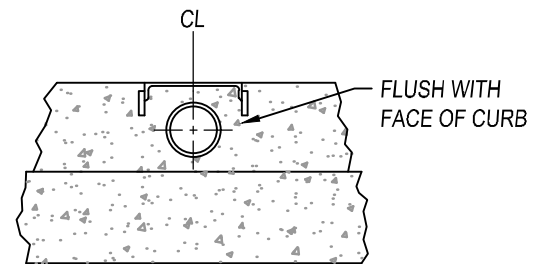

SECTION B-B

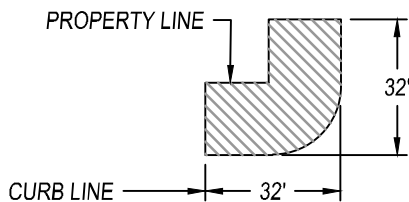

DRAIN SHALL NOT OCCUPY THE HATCH AREA

BLOCK CORNER

NOTES:

1. FOR INSTALLATION ON EXISTING CURB AND GUTTER REFER TO CITY STD. C-7.
2. SCHEDULE 80 PVC.
3. CHANNEL MATERIAL TO BE PVC UNLESS OTHERWISE APPROVED BY THE CITY ENGINEER.

SCHEDULE		
PIPE DIA.	HEIGHT	WIDTH
3"	6" TO 8"	6"
4"	6" TO 8"	6"
6"	8" TO 10"	8"



CITY COUNCIL APPROVAL: 01/24/2023

APPROVED BY CITY ENGINEER

APPROVED BY PUBLIC WORKS DIRECTOR

SIDEWALK UNDERDRAIN PIPE

PUBLIC IMPROVEMENT STANDARDS

C-8

REVISIONS

NAME	BY	DATE

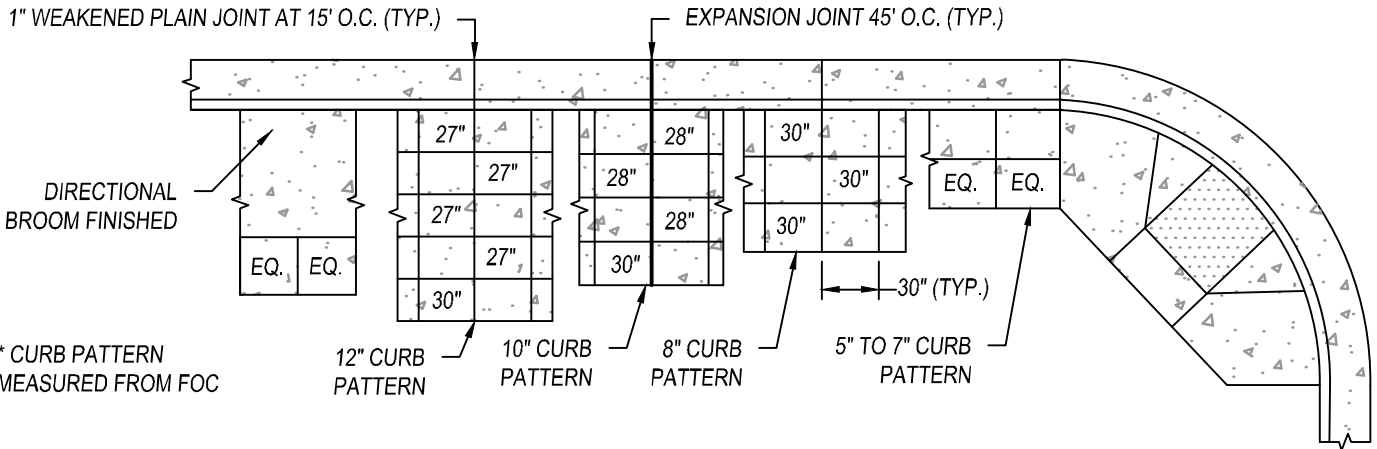

PLANS OF SIDEWALK, CURB & GUTTER, AND SCRIBE LINE DETAILS

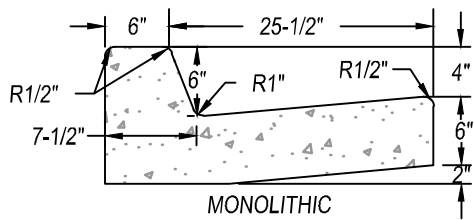

SECTION OF CURB & GUTTER

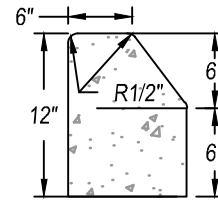

CURB

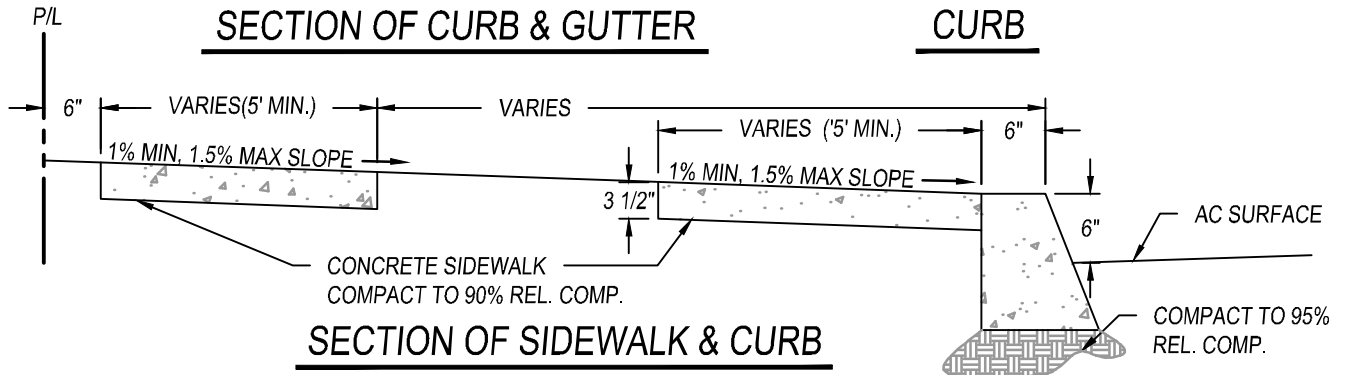

SECTION OF SIDEWALK & CURB

NOTES:

1. AREA BETWEEN CURB AND SIDEWALK SHALL BE FILLED LEVEL WITH CLEAN TOPSOIL FREE OF DEBRIS.
2. IF BICYCLE/PEDESTRIAN PATH REQUIRED, MINIMUM SIDEWALK WIDTH. CONTRACTOR SHALL FILL AREA BETWEEN NEW GUTTER AND EXISTING STREET SURFACE WITH MIN 5" ASPHALT CONCRETE.
3. SIDEWALKS, CURBS AND GUTTERS TO BE CLASS 3 CONCRETE; EXTRUDED CURB SHALL BE CLASS 2.
4. APPLY TACK COAT TO GUTTER PAN FACE AND EXISTING AC PRIOR TO PAVING.
5. BROOM FINISH ON CURB AND GUTTER AND SIDEWALK MED, SWEAT FINISH ON SIDEWALK IS OPTIONAL OR AS DIRECTED BY THE CITY ENGINEER.
6. BROOM FINISH SHALL BE PERPENDICULAR TO THE PATH OF TRAVEL ON SIDEWALK, AND PARALLEL TO THE PATH OF TRAVEL ON CURB AND GUTTER.
7. CURB AND GUTTER SUBGRADE, COMPACT TO 95% SIDEWALK SUBGRADE COMPACT TO 90% BEHIND DROVE APPROACH, 95%.
8. EXPANSION JOINT MATERIAL SHALL CONSIST OF 1/4" THICK PREMOLDED JOINT MATERIAL MEETING ASTM DESIGNATION D-1751.
9. ALL WORK CONSTRUCTED BY THIS STANDARD SHALL BE COMPLETED IN COMPLIANCE WITH CURRENT ADA REGULATIONS.
10. FINISH OF CONCRETE SHOULD MATCH ADJACENT PRE-EXISTING CONCRETE.
11. ANY UTILITY BOXES THAT ENCR OACH THE SIDEWALK SHALL BE BORDERED BY A 12" CONCRETE COLLAR A MINIMUM OF 3 1/2" THICK.
12. ALL SIDEWALK REPLACEMENT OR REPAIRS SHALL INSTALL #4 DOWEL BARS, 12" IN LENGTH AND TIE-IN EXISTING CONCRETE IMPROVEMENT AT 18" O.C. OR AS DIRECTED BY THE CITY ENGINEER.



CITY COUNCIL APPROVAL: 01/24/2023
 APPROVED BY CITY ENGINEER
 APPROVED BY PUBLIC WORKS DIRECTOR

CURB, GUTTER AND SIDEWALK

PUBLIC IMPROVEMENT STANDARDS

C-9

REVISIONS

NAME	BY	DATE

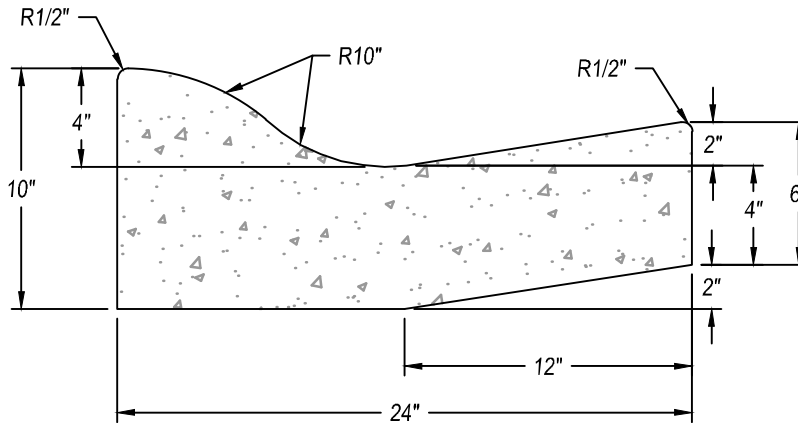

ROLL TYPE CURB AND GUTTER

(PLANNED UNIT DEVELOPMENTS ONLY)

NOTES:

1. ALL WORK SHALL CONFORM TO THE APPLICABLE SECTIONS OF THE CURRENT STATE STANDARD SPECIFICATIONS.
2. SUBGRADE PREPARATION FOR ROLL TYPE CURBS AND GUTTERS SHALL BE CONSTRUCTED TRUE TO GRADE AND CROSS SECTION WITH MINIMUM RELATIVE COMPACTION OF 95% TO A MIN. DEPTH OF 6" BELOW THE SUBGRADE.
3. CONCRETE FOR CURB AND GUTTER SHALL BE CLASS "A" (6 SACK MIN.) AND SHALL BE WITHIN 2.5" TO 5.5" SLUMP.
4. TIMBER FORMS SHALL BE SURFACED ON THE SIDE PLACED NEXT TO THE CONCRETE AND SHALL NOT BE LESS THAN 1.5" THICK AFTER BEING SURFACED.
5. TOP AND FACE SHALL BE TROWELED SMOOTH, THEN GIVEN A FINAL MEDIUM BRUSH FINISH.
6. WHERE EXISTING CURB AND GUTTERS ARE TO BE REPLACED, NEW CONSTRUCTION SHALL MATCH EXISTING CONSTRUCTION UNLESS OTHERWISE DIRECTED BY THE CITY ENGINEER.
7. CONCRETE SHALL CONTAIN NO ADDITIVES UNLESS PRIOR APPROVAL IS OBTAINED FROM THE CITY ENGINEER.
8. EXISTING SECTIONS OF CURB AND GUTTER SHALL BE SAWCUT AT THE LIMITS OF THE AREA TO BE RECONSTRUCTED.
9. WEAKENED PLANE JOINTS OR COLD JOINTS SHALL BE CONSTRUCTED AT 15' INTERVALS. EXPANSION JOINTS SHALL BE AT EACH SIDE OF STRUCTURES AND AT END OF CURB RETURNS.
10. ROLL TYPE CURB AND GUTTER SHALL BE APPROVED BY THE CITY PRIOR TO PERMIT ISSUANCE.
11. PERMIT FOR CURB AND GUTTER CONSTRUCTION SHALL ACCOMPANY ACTUAL WORK.
12. WHEN CONSTRUCTING NEW CURB AND GUTTER, THE EXISTING PAVEMENT SHALL BE SAWCUT A MINIMUM OF 2.0' FROM THE LIP OF THE GUTTER OR AS DIRECTED BY THE CITY ENGINEER.



CITY COUNCIL APPROVAL: 01/24/2023

[Signature]
APPROVED BY CITY ENGINEER

[Signature]
APPROVED BY PUBLIC WORKS DIRECTOR

ROLL TYPE CURB AND GUTTER

PUBLIC IMPROVEMENT STANDARDS

C-10

REVISIONS

NAME	BY	DATE

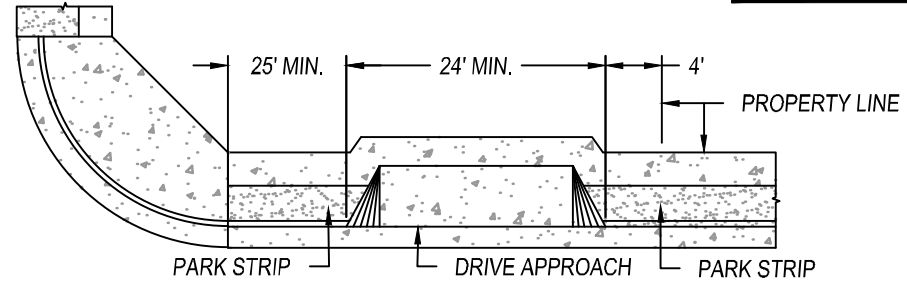
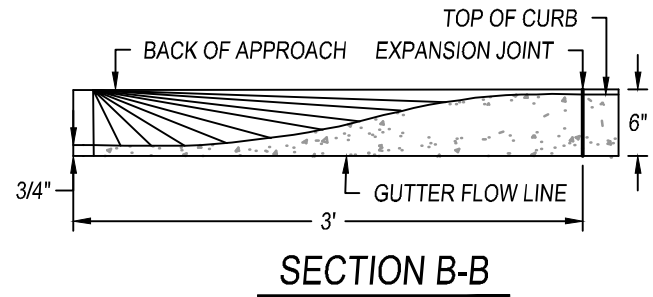
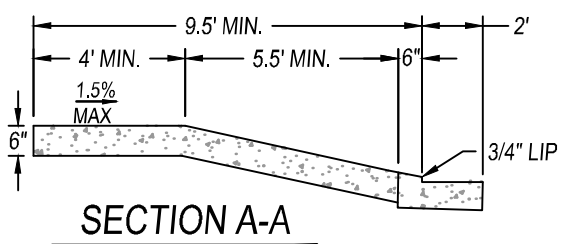
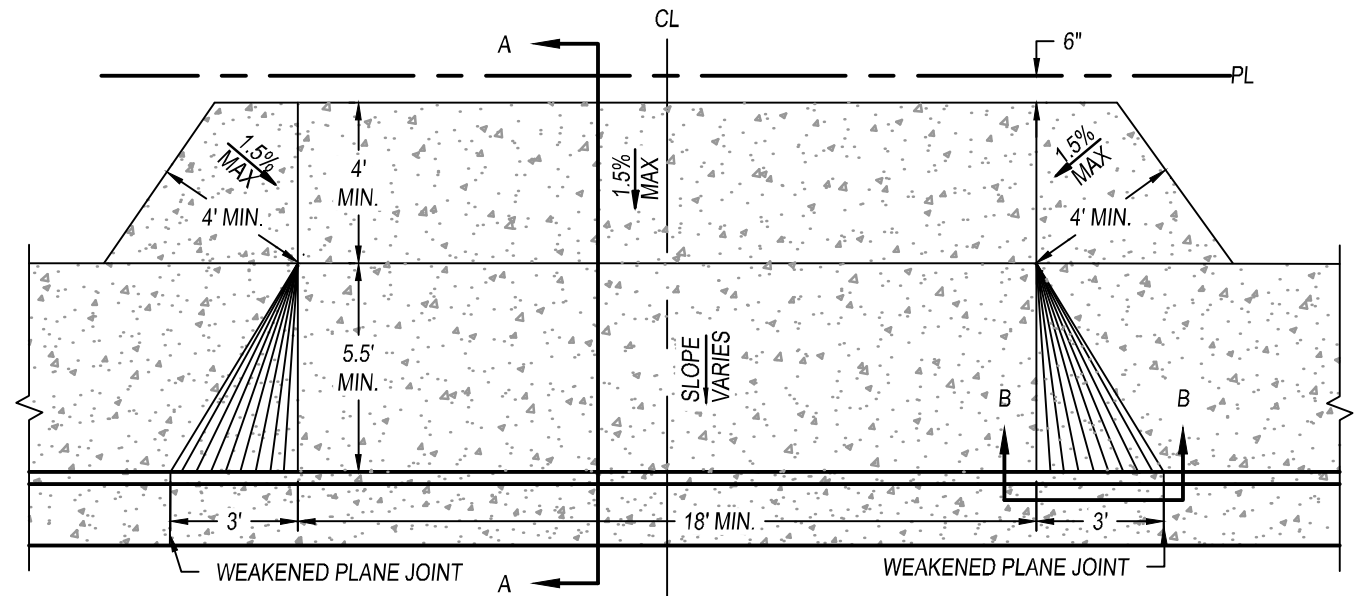

DRIVE APPROACH DISTANCE

NOTES:

1. ENTIRE WIDTH OF DRIVE APRON TO PL SHALL HAVE A MIN. THICKNESS OF 6" OF CONCRETE.
2. DRIVE OPENINGS SHALL BE A MIN. OF 14' MEASURED FROM OUT SIDE THROAT TO OUTSIDE THROAT APART WHEN LOCATED ON THE SAME PROPERTY. NOT MORE THAN 40% OF THE BUILDING SITE FRONTAGE SHALL BE USED FOR VEHICULAR ACCESS.
3. THERE SHALL BE 25' MIN. SETBACK FROM CURB AND GUTTER RADIUS END TO DRIVE APPROACH. THIS DISTANCE MAY BE INCREASED AT THE DISCRETION OF THE CITY ENGINEER.
4. ALL CONCRETE SHALL BE CLASS "A" (6 SACK MINIMUM) AND TEST TO A MIN. OF 2,500 P.S.I. IN 28 DAYS.
5. DRIVEWAYS SHALL BE FORMED TO FULL DEPTH OF POUR.
6. SUBGRADE UNDER DRIVEWAY APPROACH SHALL BE COMPACTED TO 95% MIN. RELATIVE COMPACTION.
7. THE DRIVEWAY SURFACE SHALL HAVE A HEAVY BROOM FINISH.
8. THE BOTTOM FRONT LIP OF THE DRIVEWAY ENTRANCE SHALL HAVE A 45 DEG. BEVEL.
9. 22' MINIMUM DISTANCE BETWEEN DOUBLE APPROACH FROM EDGE OF FLARE TO EDGE OF FLARE.



CITY COUNCIL APPROVAL: 01/24/2023
 APPROVED BY CITY ENGINEER
 APPROVED BY PUBLIC WORKS DIRECTOR

RESIDENTIAL DRIVE APPROACH
PUBLIC IMPROVEMENT STANDARDS

C-11		
REVISIONS		
NAME	BY	DATE

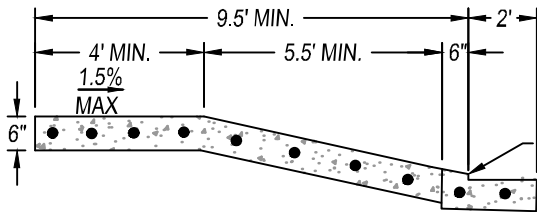
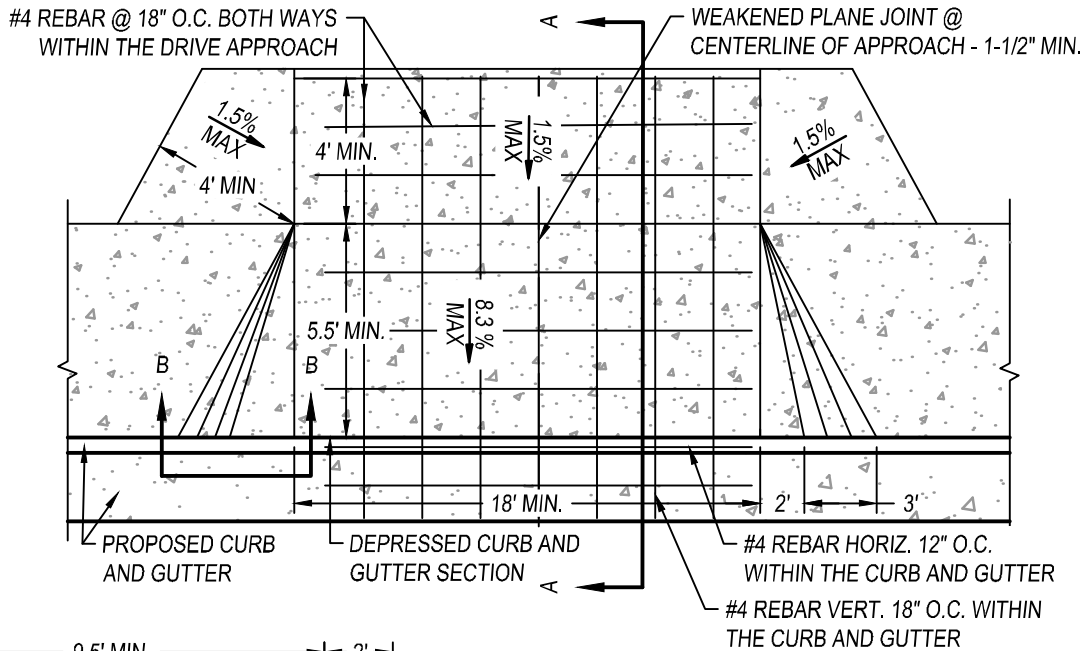

SECTION A-A

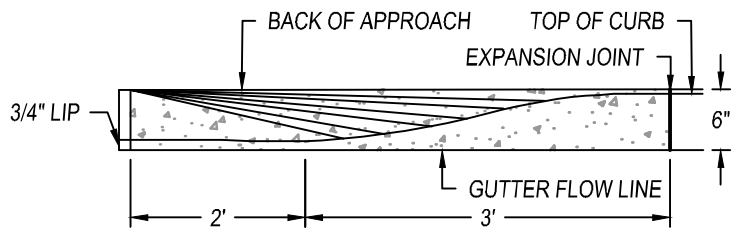

SECTION B-B

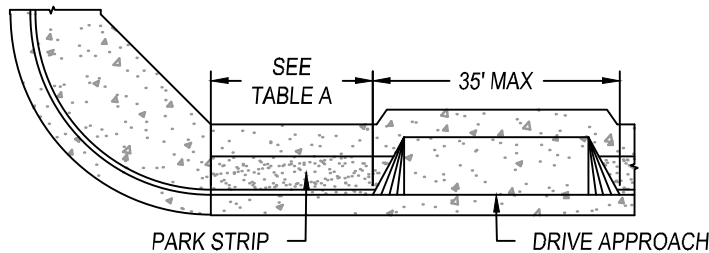

DRIVE APPROACH LOCATION

TABLE A	
TYPE OF STREET	DISTANCE
ARTERIAL STREET	100'-0"
COLLECTOR STREET	50'-0"
LOCAL STREET	35'-0"

NOTES:

- ENTIRE WIDTH OF DRIVE APRON TO PL SHALL HAVE A MIN. THICKNESS OF 8" OF CONCRETE.
- DRIVE OPENINGS SHALL BE A MIN. OF 24' APART WHEN LOCATED ON THE SAME PROPERTY. NOT MORE THAN 70% OF THE BUILDING SITE FRONTAGE SHALL BE USED FOR VEHICULAR ACCESS.
- THERE SHALL BE 35' MIN. SETBACK FROM CURB AND GUTTER RADIUS END TO DRIVE APPROACH. THIS DISTANCE MAY BE INCREASED AT THE DISCRETION OF THE CITY ENGINEER.
- ALL CONCRETE SHALL BE CLASS "A" (6 SACK MINIMUM) AND TEST TO A MIN. OF 3,000 P.S.I. IN 28 DAYS.
- DRIVE APPROACHES SHALL BE FORMED TO FULL DEPTH OF POUR.
- SUBGRADE UNDER THE DRIVE APPROACH SHALL BE COMPACTED TO 95% MIN. REL. COMP.
- THE DRIVE APPROACH SURFACE SHALL HAVE A HEAVY "BROOM" FINISH.
- THE BOTTOM FRONT LIP OF THE DRIVE APPROACH ENTRANCE SHALL HAVE A 45 DEG. BEVEL.



CITY COUNCIL APPROVAL: 01/24/2023

APPROVED BY CITY ENGINEER

APPROVED BY PUBLIC WORKS DIRECTOR

COMMERCIAL DRIVE APPROACH

PUBLIC IMPROVEMENT STANDARDS

C-12

REVISIONS

NAME	BY	DATE

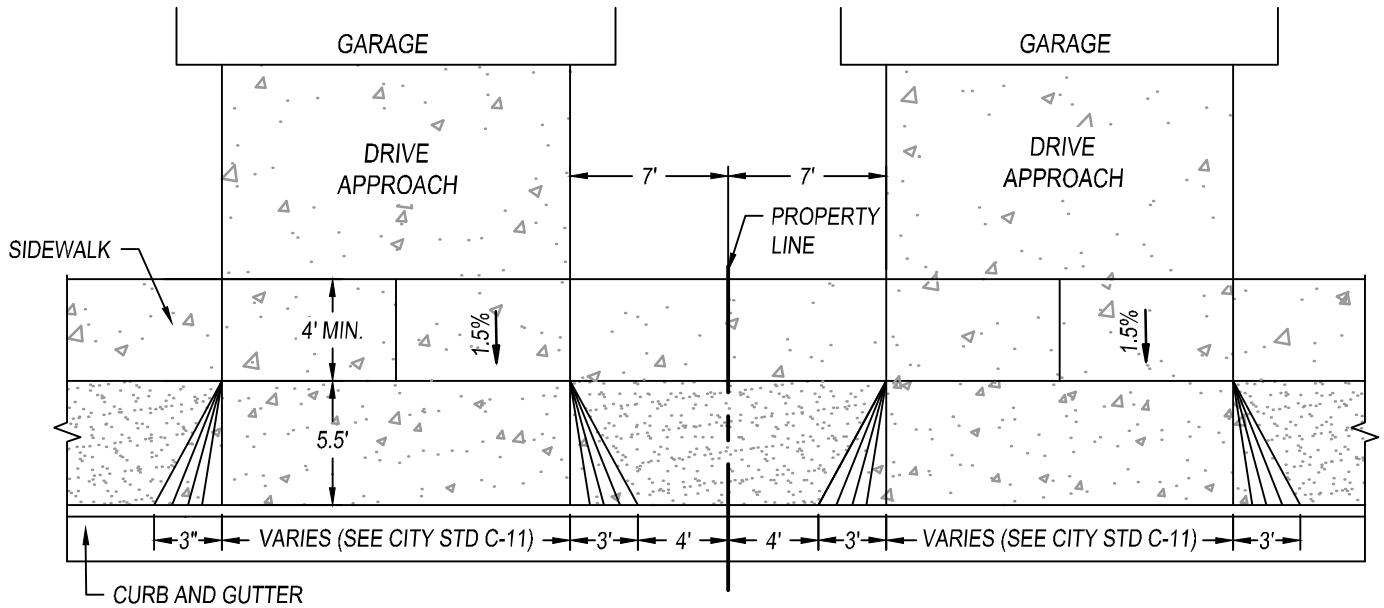

DRIVEWAY APPROACH WITH PLANTER

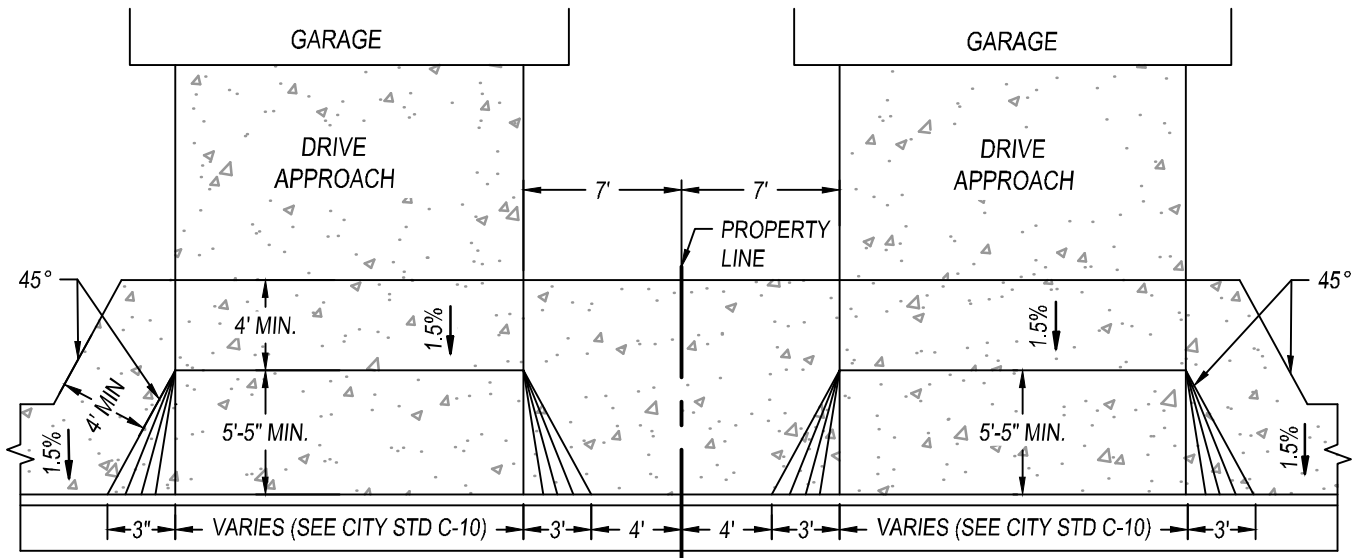

DRIVEWAY APPROACH WITHOUT PLANTER

NOTES:

1. THE SIDEWALK BEHIND THE DRIVE APPROACH SHALL BE 6" THICK.
2. SIDEWALK SUB-GRADE BEHIND THE DRIVE APPROACH SHALL BE 95% MINIMUM RELATIVE COMPACTED.



CITY COUNCIL APPROVAL: 01/24/2023
 APPROVED BY CITY ENGINEER
 APPROVED BY PUBLIC WORKS DIRECTOR

**TYPICAL DRIVE APPROACH
 LOCATION
 PUBLIC IMPROVEMENT STANDARDS**

C-13		
REVISIONS		
NAME	BY	DATE

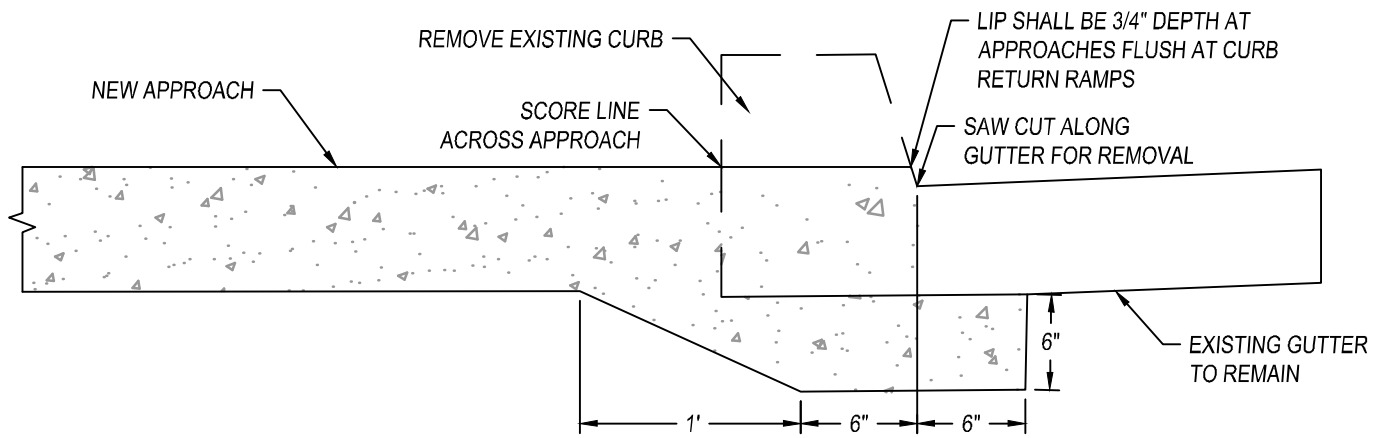

CITY COUNCIL APPROVAL: 01/24/2023

[Signature]
APPROVED BY CITY ENGINEER

[Signature]
APPROVED BY PUBLIC WORKS DIRECTOR

EXISTING CURB REMOVAL

PUBLIC IMPROVEMENT STANDARDS

C-14

REVISIONS		
NAME	BY	DATE

NOTES:

1. IN ACCORDANCE TO THE DEPARTMENT OF TRANSPORTATION AND THE NATIONAL ELECTRICAL CODE, AND THESE SPECIAL PROVISIONS.
2. LUMINARIES SHALL BE LIGHT EMITTING DIODE TYPE, LEDWAY STREETLIGHT TYPE III MEDIUM, AS MANUFACTURED BY BETALED, OR APPROVED EQUAL.
3. ALL STREET LIGHTS SHALL BE NUMBERED, NUMERICAL SEQUENCE TO BE OBTAINED FROM P.G.&E. NUMBERS TO BE 1-1/2" HIGH AND INSTALLED NINE FEET ABOVE FINISHED GRADE, FACING STREET.
4. A PULL BOX WILL BE REQUIRED WHEREVER CONDUIT CHANGES DIRECTION AND WHERE MULTIPLE LIGHTS ARE INSTALLED ON A SINGLE SERVICE. PULL BOX SPACING SHALL NOT EXCEED 200'.
6. NUMBERING SEQUENCE SHALL BE OBTAINED FROM THE PUBLIC WORKS DEPARTMENT

STREET LIGHT DIMENSION				
	A	B	C	D
LOCAL STREET	8'	2'	28'	26'-6"
COLLECTOR STREET	12'	4'-3"	33'-9"	30'

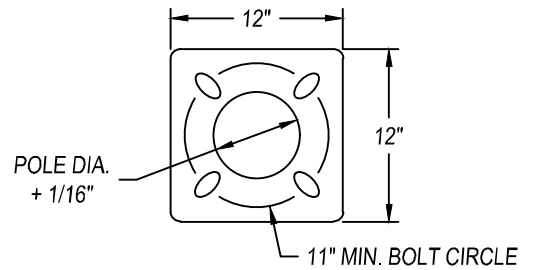

BASE PLATE DETAIL

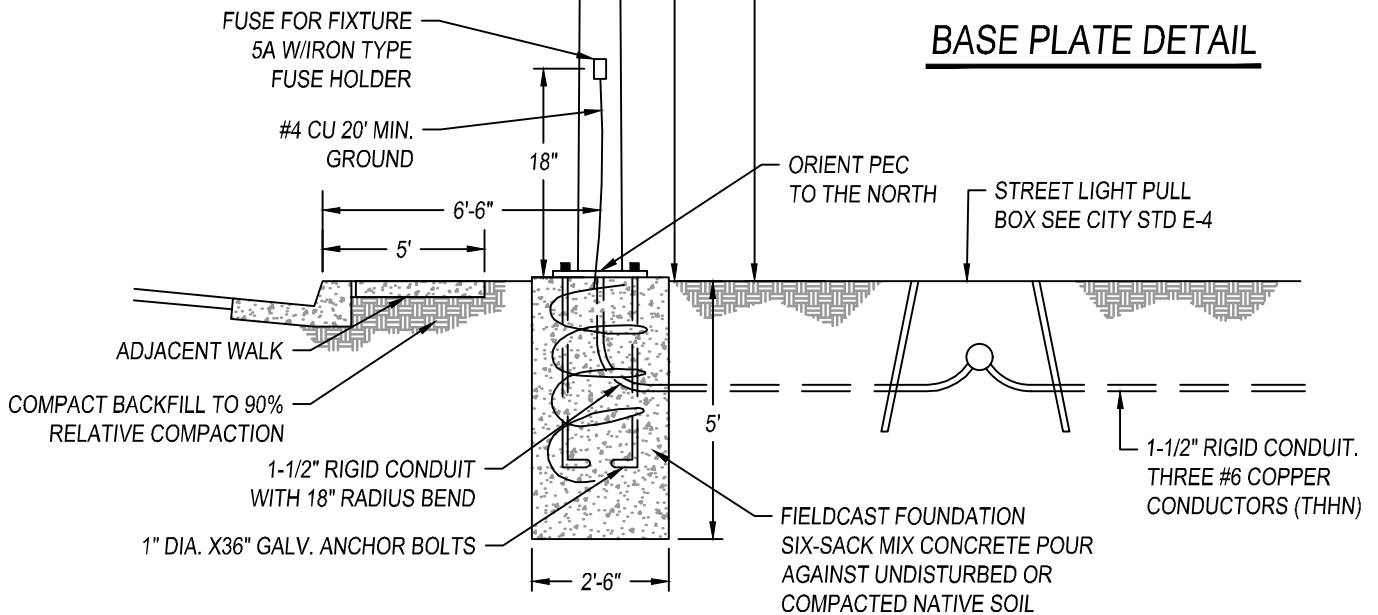
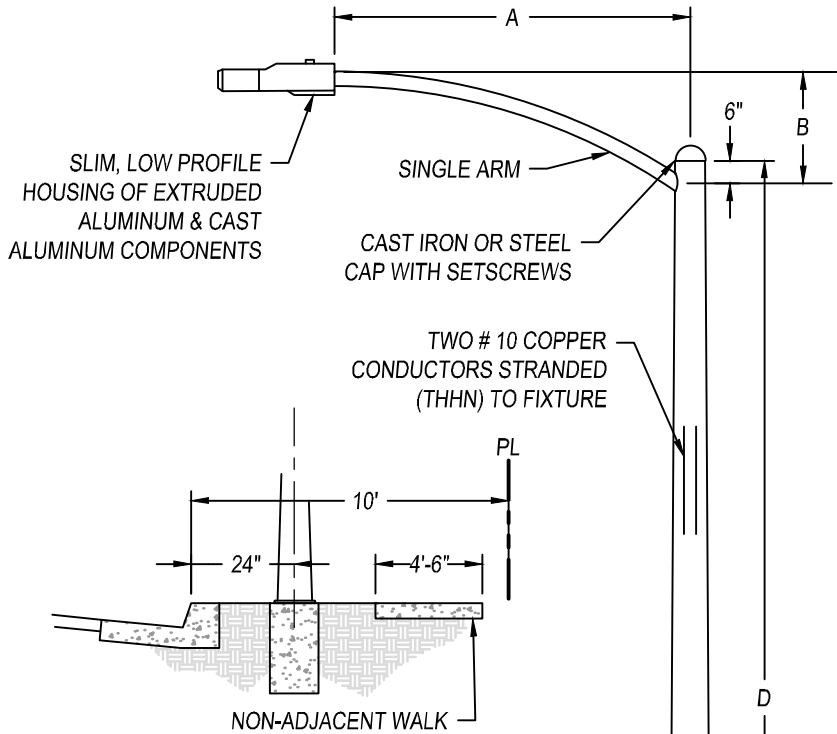

CITY COUNCIL APPROVAL: 01/24/2023
 APPROVED BY CITY ENGINEER
 APPROVED BY PUBLIC WORKS DIRECTOR

STREETLIGHT

PUBLIC IMPROVEMENT STANDARDS

E-1

REVISIONS

NAME	BY	DATE

NOTES:

1. ALL WORK ALL CONFORM TO THE LATEST VERSION OF THE NATIONAL ELECTRIC CODE.
2. DECORATIVE STREETLIGHTS SHALL BE HOLOPHANE AWDE3 OR OTHER WISED APPROVED BY THE CITY ENGINEER.
3. STREETS LIGHTS SHALL BE 18" BEHIND SIDEWALK WHEN SIDEWALK IS ADJACENT TO CURB. WHEN NON-ADJACENT SIDE WALK LIGHTS SHALL BE 24" BEHIND FACE OF CURB.
4. PRIOR TO INSTALLATION A STREET LIGHT PLAN SHALL BE SUBMITTED FOR APPROVAL TO THE CITY ENGINEER.
5. ORIENTATED PHOTO CELL PEC TO NORTH.
6. NUMBERING SEQUENCE SHALL BE OBTAINED FROM THE PUBLIC WORKS DEPARTMENT

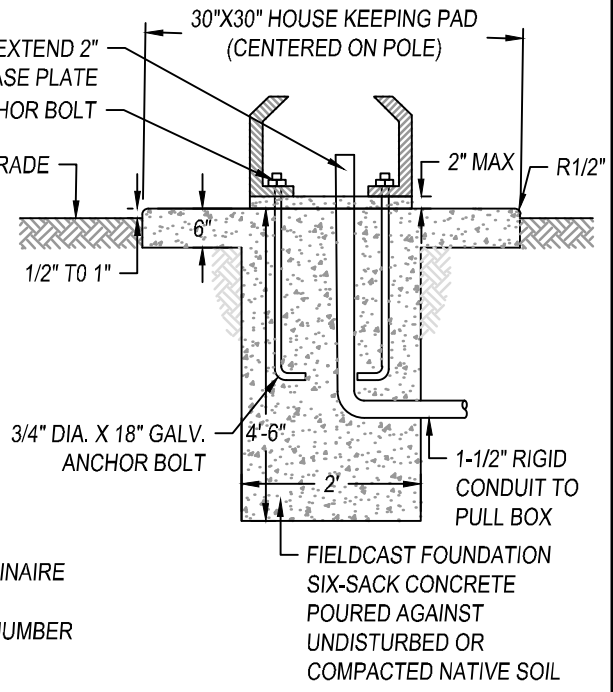

FOUNDATION DETAIL

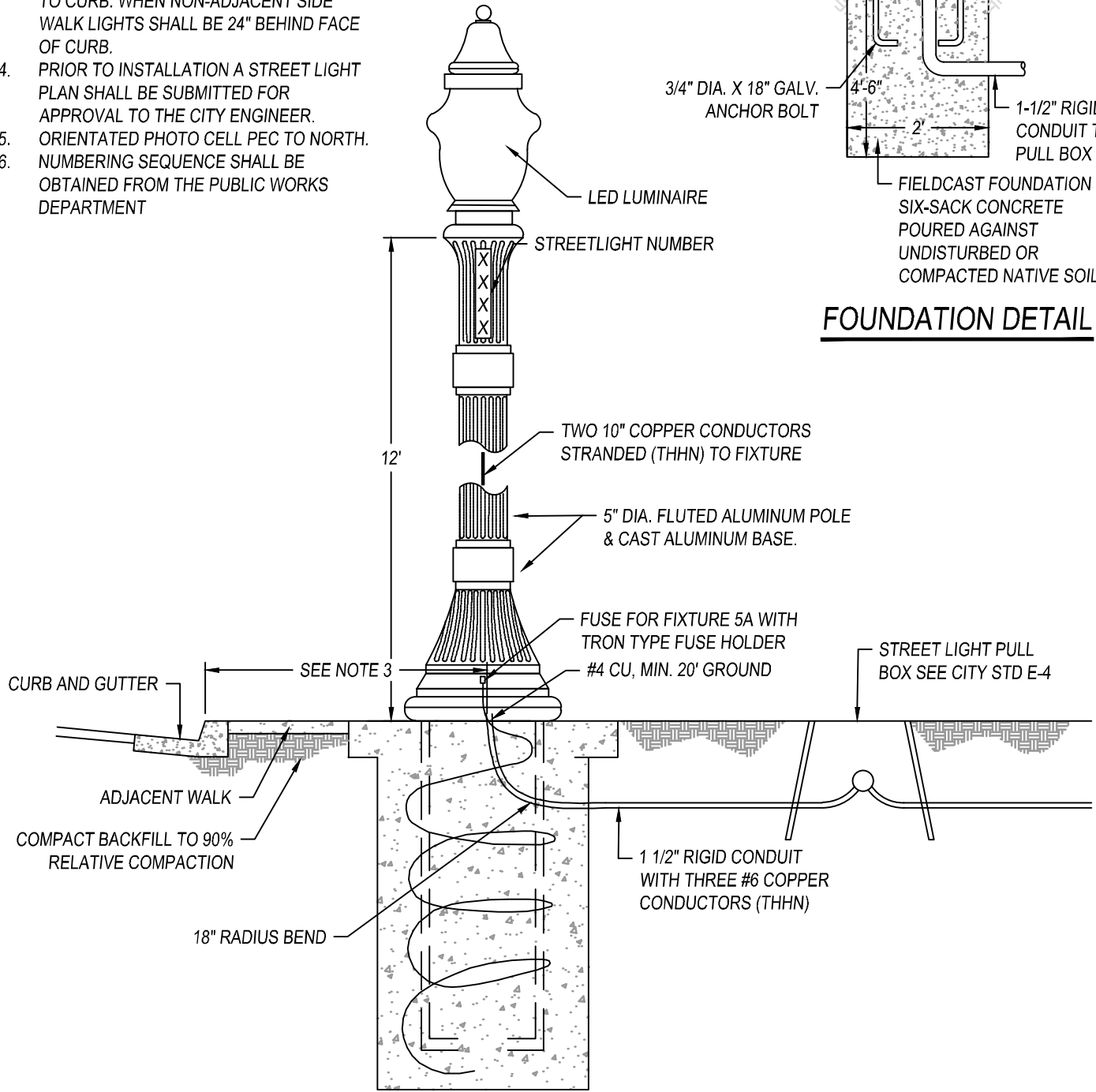

CITY COUNCIL APPROVAL: 01/24/2023
 APPROVED BY CITY ENGINEER
 APPROVED BY PUBLIC WORKS DIRECTOR

DECORATIVE STREETLIGHT

PUBLIC IMPROVEMENT STANDARDS

E-2		
REVISIONS		
NAME	BY	DATE

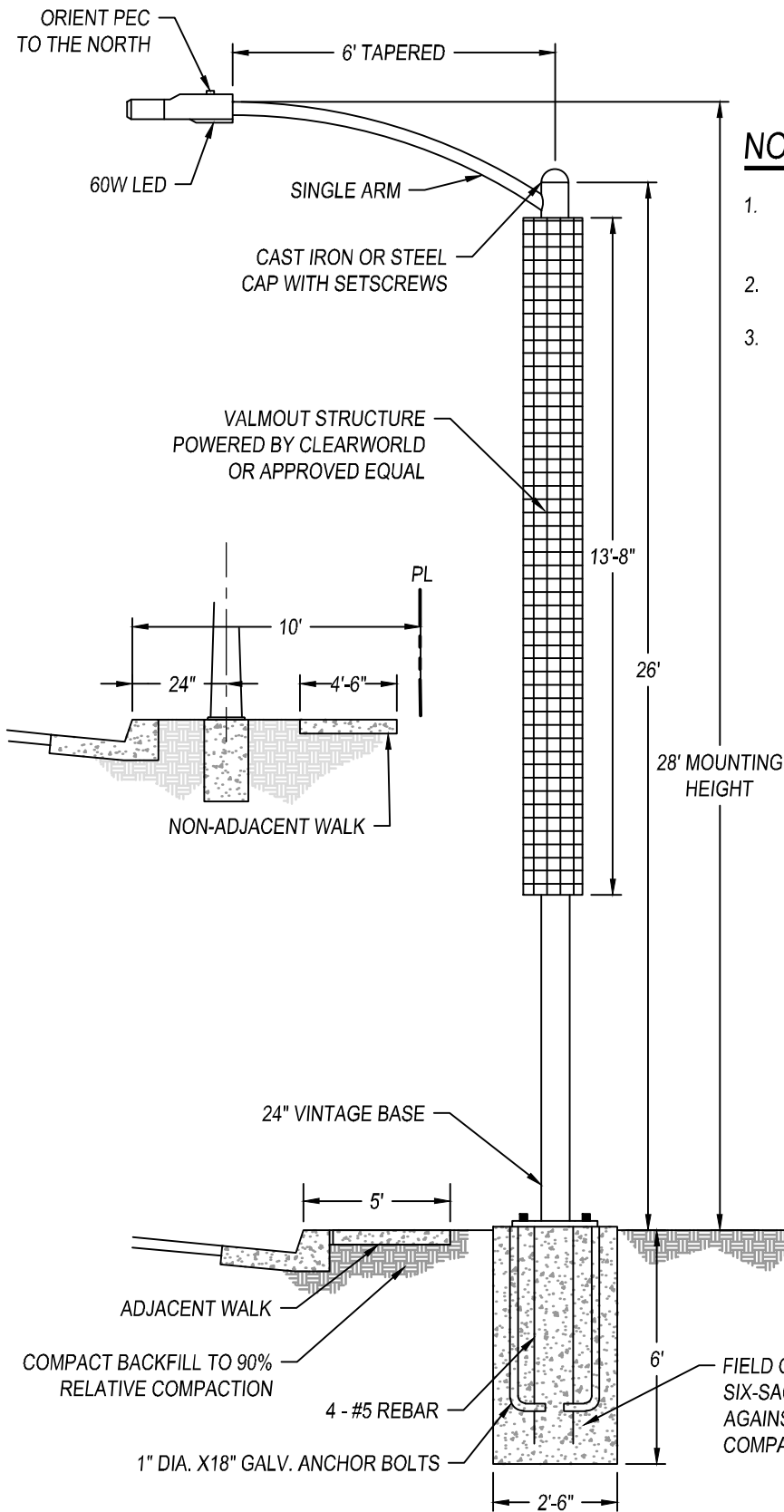

NOTES:

1. IN ACCORDANCE TO THE DEPARTMENT OF TRANSPORTATION AND THE NATIONAL ELECTRICAL CODE, AND THESE SPECIAL PROVISIONS.
2. STREETLIGHT SHALL BE VALMOUT STRUCTURE POWERED BY CLEARWORLD OR APPROVED EQUAL.
3. ALL STREET LIGHTS SHALL BE NUMBERED. NUMBER SEQUENCE SHALL BE OBTAINED FROM THE PUBLIC WORKS DEPARTMENT.

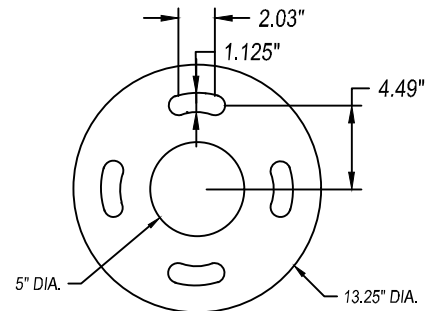

BASE PLATE DETAIL



CITY COUNCIL APPROVAL: 01/24/2023
 APPROVED BY CITY ENGINEER
 APPROVED BY PUBLIC WORKS DIRECTOR

SOLAR STREETLIGHT

PUBLIC IMPROVEMENT STANDARDS

E-3

REVISIONS		
NAME	BY	DATE

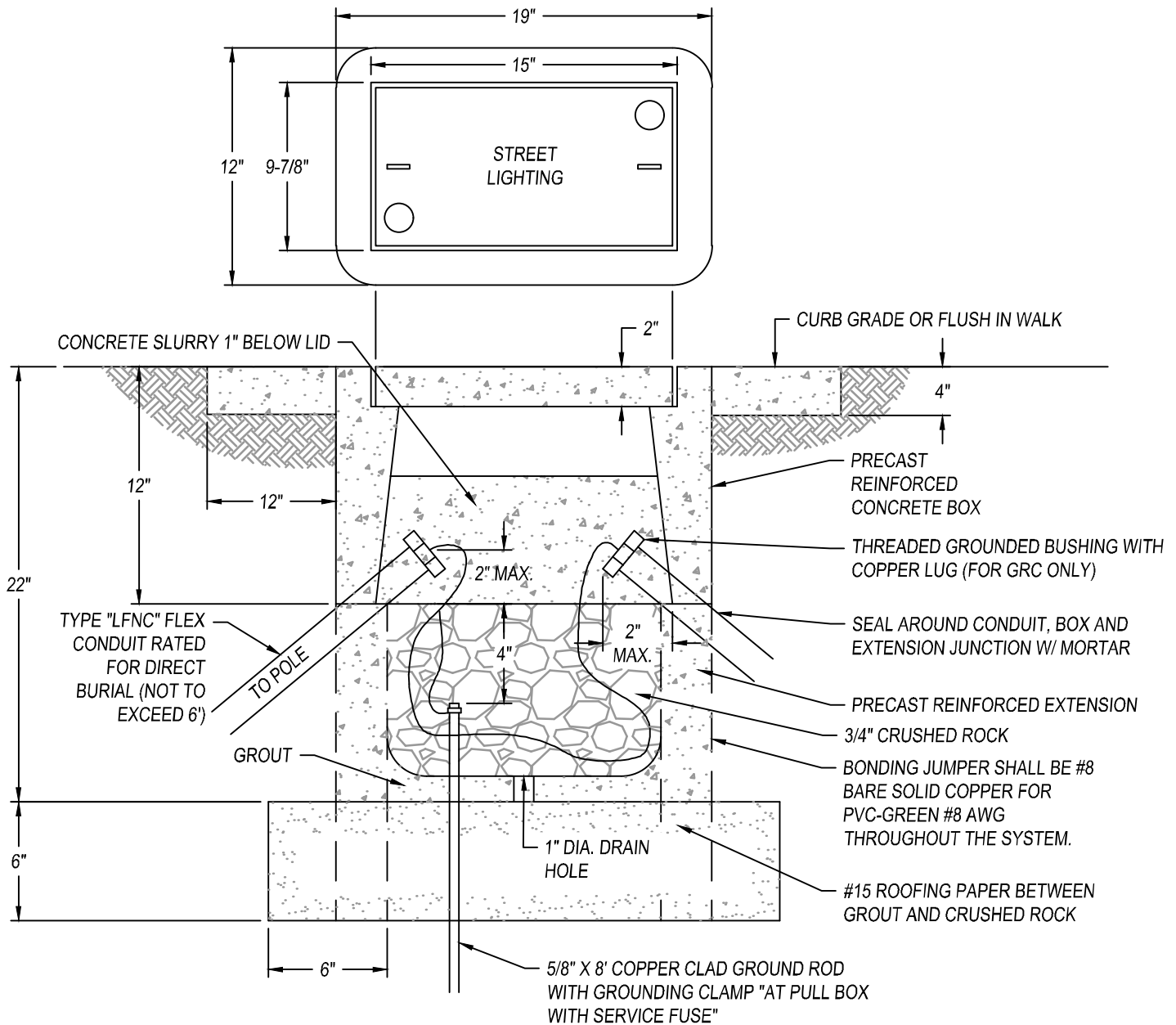

NOTES:

1. PULL BOXES SHALL BE #3-1/2 AS PER CAL-TRANS STANDARD SPECIFICATION OR CHRISTY N-9 OR APPROVED EQUAL. LIDS SHALL HAVE HOLD DOWN BOLTS.
2. PULL BOXES SHALL BE GROUTED PRIOR TO INSTALLATION OF CONDUCTORS, SLOPED TOWARD THE DRAIN HOLE. PLACE A LAYER OF ROOFING PAPER BETWEEN THE CRUSHING ROCK AND THE GROUT.
3. PULL LIDS BEFORE POURING CONCRETE AROUND PULL BOXES.
4. WRAP PULL BOX WITH ROOFING PAPER BEFORE BACKFILLING.
5. FUSE AT POINT OF SERVICE SHALL BE 60A IF #6 CONDUCTOR AND 40A IF #8 CONDUCTOR AND SHALL HAVE A TRON TYPE FUSE HOLDER. (SINGLE POLE)
6. INSTALL A ONE-FOOT RING OF CONCRETE, FOUR INCHES DEEP, AROUND THE WRAPPED PULL BOXES INSTALLED IN DIRT AREAS. SLOPED TO DRAIN AWAY FROM THE PULL BOX.
7. WHEN PULL BOXES ARE LOCATED ADJACENT TO STREET LIGHT, EXTEND CONCRETE RING TO INCLUDE 12" CIRCUMFERENCE AROUND POLE.
8. PULL BOXES TO BE INSTALLED PARALLEL TO STREET AND/OR CURB OR GUTTER.
9. EACH PULL BOX WILL HAVE A LOCKABLE CAST IRON CHRISTY BOX LID.



CITY COUNCIL APPROVAL: 01/24/2023

APPROVED BY CITY ENGINEER

APPROVED BY PUBLIC WORKS DIRECTOR

STREETLIGHT CONCRETE PULL BOX

PUBLIC IMPROVEMENT STANDARDS

E-4		
REVISIONS		
NAME	BY	DATE

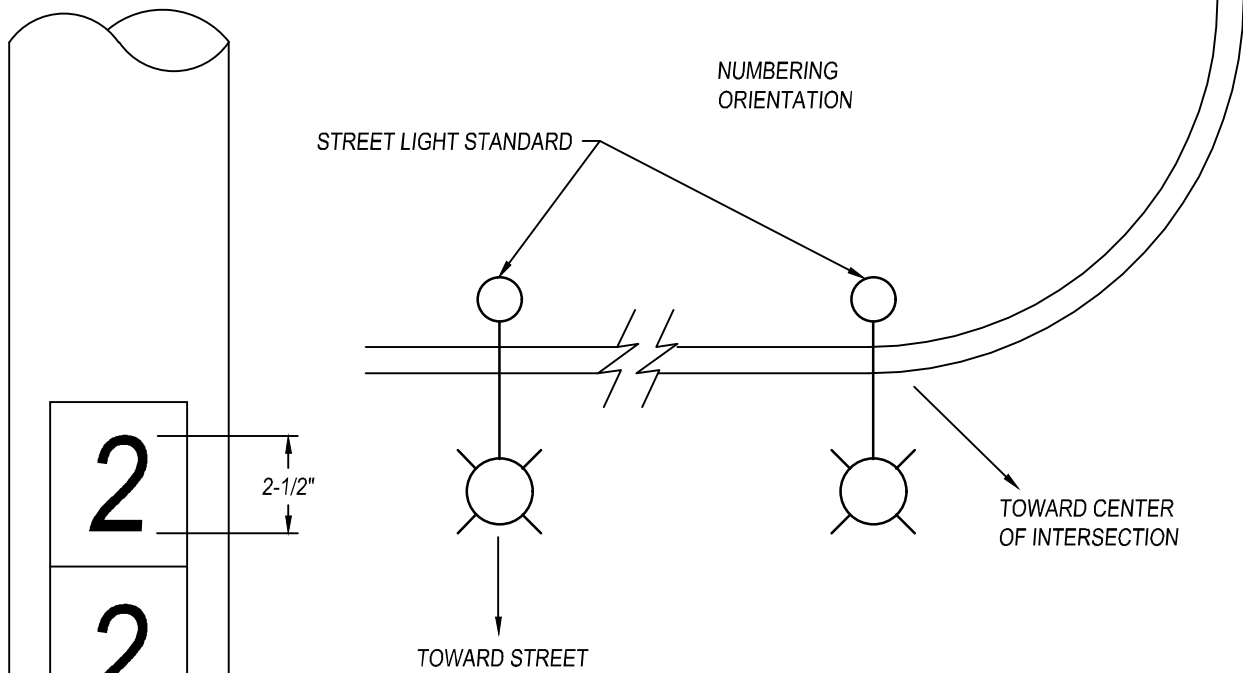

NOTES:

1. FOR METAL POLES, APPLY TO CLEAN SURFACE.
2. BACKING PLATE SHALL BE ALMETEK EMP-2.5V5 OR APPROVED EQUAL ON CITY APPROVED POLES.
3. FOR WOOD POLES, USE EMBOSSED ALUMINUM BACKING PLATE SECURED W/ 1-1/2" ALUMINUM ROOFING NAILS.
4. NUMERALS SHALL BE ALMETEK PS-2.5 SERIES OR APPROVED EQUAL
5. PRESSURE SENSITIVE MARKERS OF REFLECTIVE SCOTCHLITE BLACK ON WHITE BACKGROUND.
6. PG&E SHALL ASSIGN A POLE NUMBER.
7. DEVELOPER/CONTRACTOR SHALL INSTALL CITY CITY APPROVED NUMBERS ON ALL STREET LIGHT POLES.

9' FROM GRADE/SIDEWALK ELEVATION.
ADJUST AS NEEDED TO CLEAR HARDWARE
OF APPURTENANCES



CITY COUNCIL APPROVAL: 01/24/2023

[Signature]
APPROVED BY CITY ENGINEER

[Signature]
APPROVED BY PUBLIC WORKS DIRECTOR

STREETLIGHT POLE NUMBERING

PUBLIC IMPROVEMENT STANDARDS

E-5

REVISIONS

NAME	BY	DATE

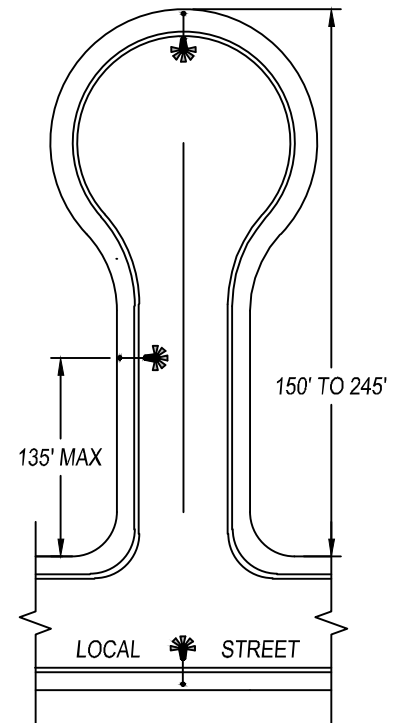
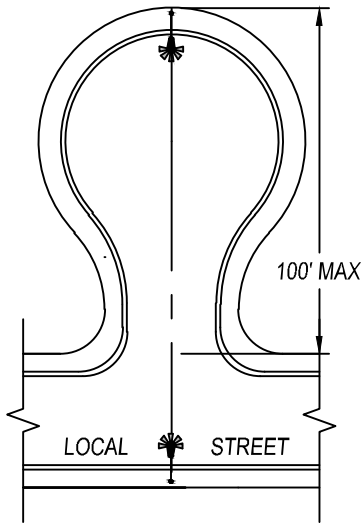
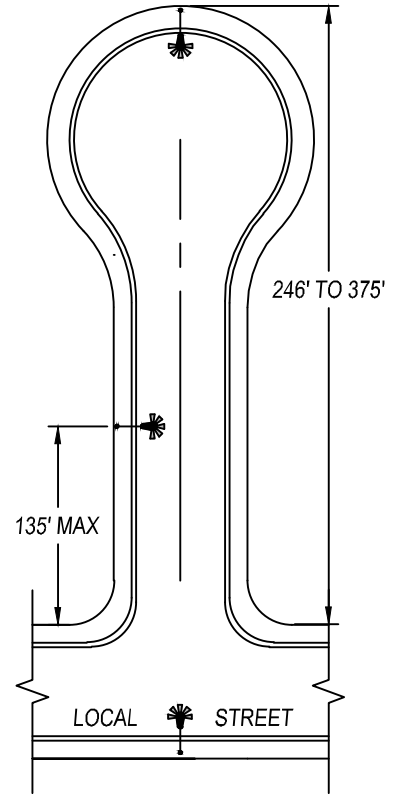
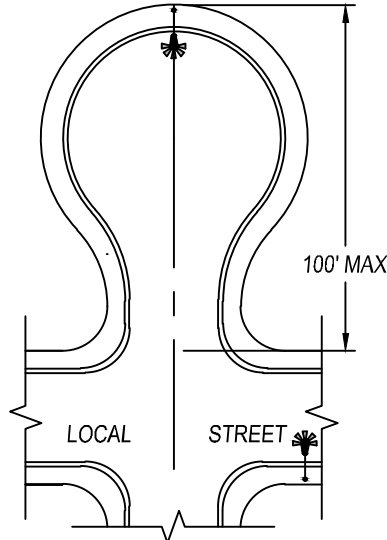
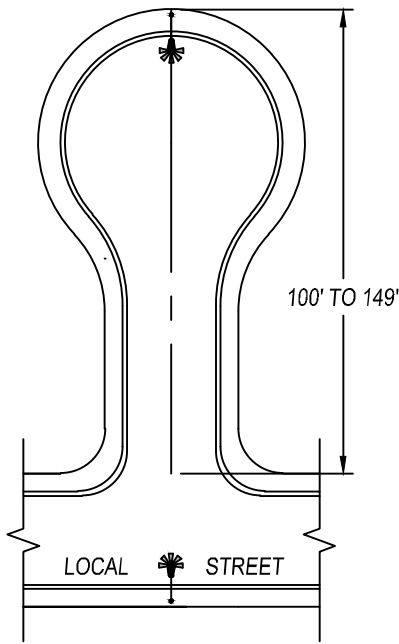

NOTES:

1. PRIOR IS INSTALLATION A LIGHTING PLAN SHALL BE SUBMITTED TO THE CITY ENGINEER FOR APPROVAL AND SHALL BE INSTALLED PER APPROVED PLAN.
2. STREETLIGHT SHALL BE INSTALLED AT EVERY INTERSECTION, IF THE SPACING EXCEEDS 360 FEET BETWEEN INTERSECTION AND STREETLIGHT SHALL BE INSTALLED BETWEEN THE INTERSECTION WITH THE MINIMUM SPACING OF 180 FEET AND MAXIMUM OF 240 FEET BETWEEN STREETLIGHTS.
3. A PULL BOX WILL BE REQUIRED WHEREVER CONDUIT CHANGES DIRECTION AND WHERE MULTIPLE LIGHTS ARE INSTALLED ON A SINGLE SERVICE. PULL BOX SPACING SHALL NOT EXCEED 200'.
4. A MINIMUM SEPARATION OF 30 FEET SHALL BE REQUIRED BETWEEN THE STREETLIGHT POLES AND ANY TREE.



CITY COUNCIL APPROVAL: 01/24/2023
 APPROVED BY CITY ENGINEER
 APPROVED BY PUBLIC WORKS DIRECTOR

**STREETLIGHT PLACEMENT -
 CUL-DE-SACS**

PUBLIC IMPROVEMENT STANDARDS

E-6

REVISIONS		
NAME	BY	DATE

NOTES:

1. ALL STREET LIGHTS SHALL BE INSTALLED PER THE LATEST VERSION OF THE NATIONAL ELECTRICAL CODE.
2. STREETLIGHT SHALL BE INSTALLED AT EVERY INTERSECTION, IF THE SPACING EXCEEDS 360 FEET BETWEEN INTERSECTION AND STREETLIGHT SHALL BE INSTALLED BETWEEN THE INTERSECTION WITH THE MINIMUM SPACING OF 180 FEET AND MAXIMUM OF 275 FEET SPACING BETWEEN UNITS TO UNIT ROADWAY WIDTH GREATER THAN 50.
3. A PULL BOX WILL BE REQUIRED WHEREVER CONDUIT CHANGES DIRECTION AND WHERE MULTIPLE LIGHTS ARE INSTALLED ON A SINGLE SERVICE. PULL BOX SPACING SHALL NOT EXCEED 200'.

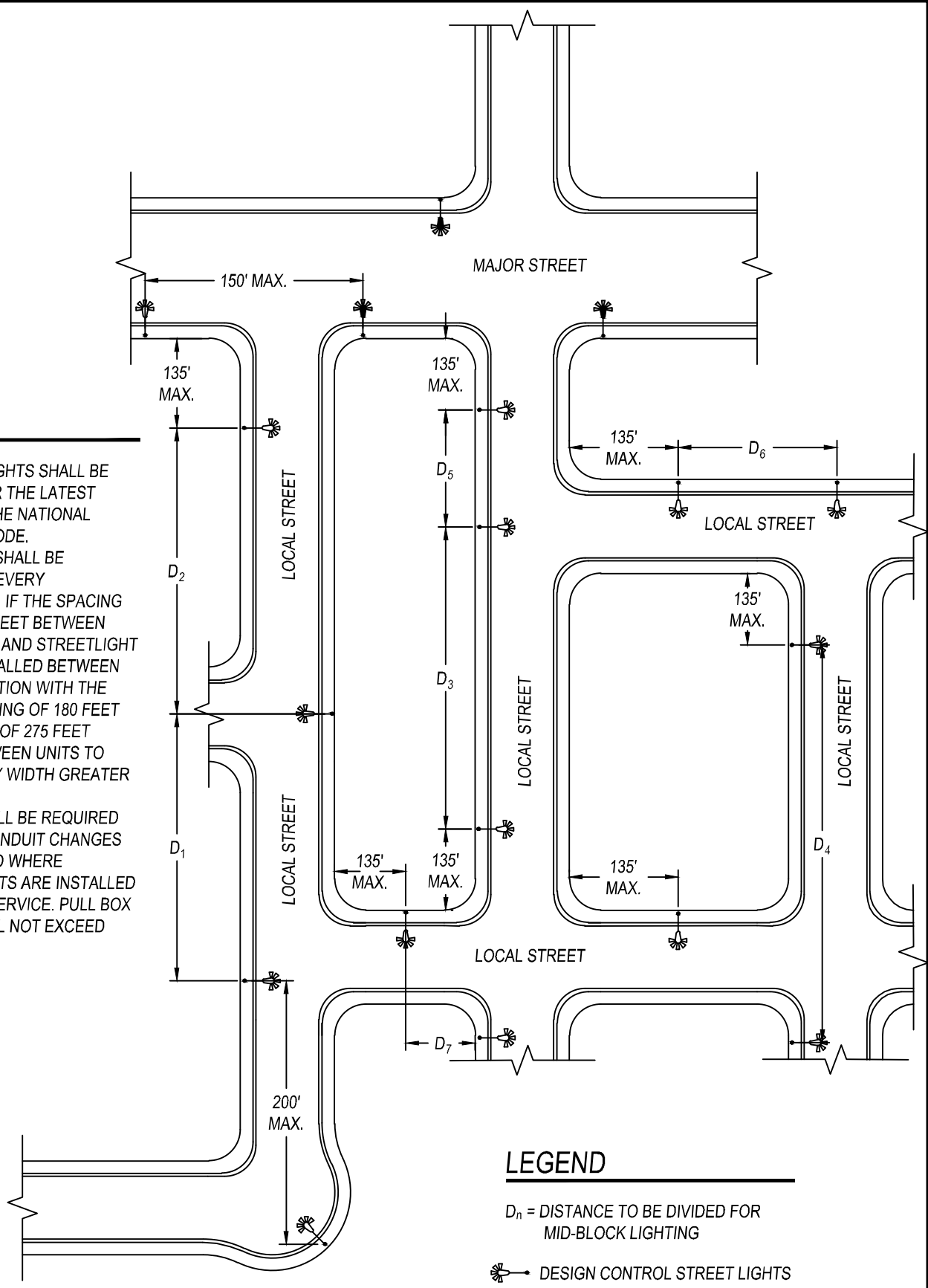

LEGEND

D_n = DISTANCE TO BE DIVIDED FOR MID-BLOCK LIGHTING
 DESIGN CONTROL STREET LIGHTS



CITY COUNCIL APPROVAL: 01/24/2023

 APPROVED BY CITY ENGINEER

 APPROVED BY PUBLIC WORKS DIRECTOR

**STREETLIGHT PLACEMENT -
 LOCAL STREET
 PUBLIC IMPROVEMENT STANDARDS**

E-7		
REVISIONS		
NAME	BY	DATE

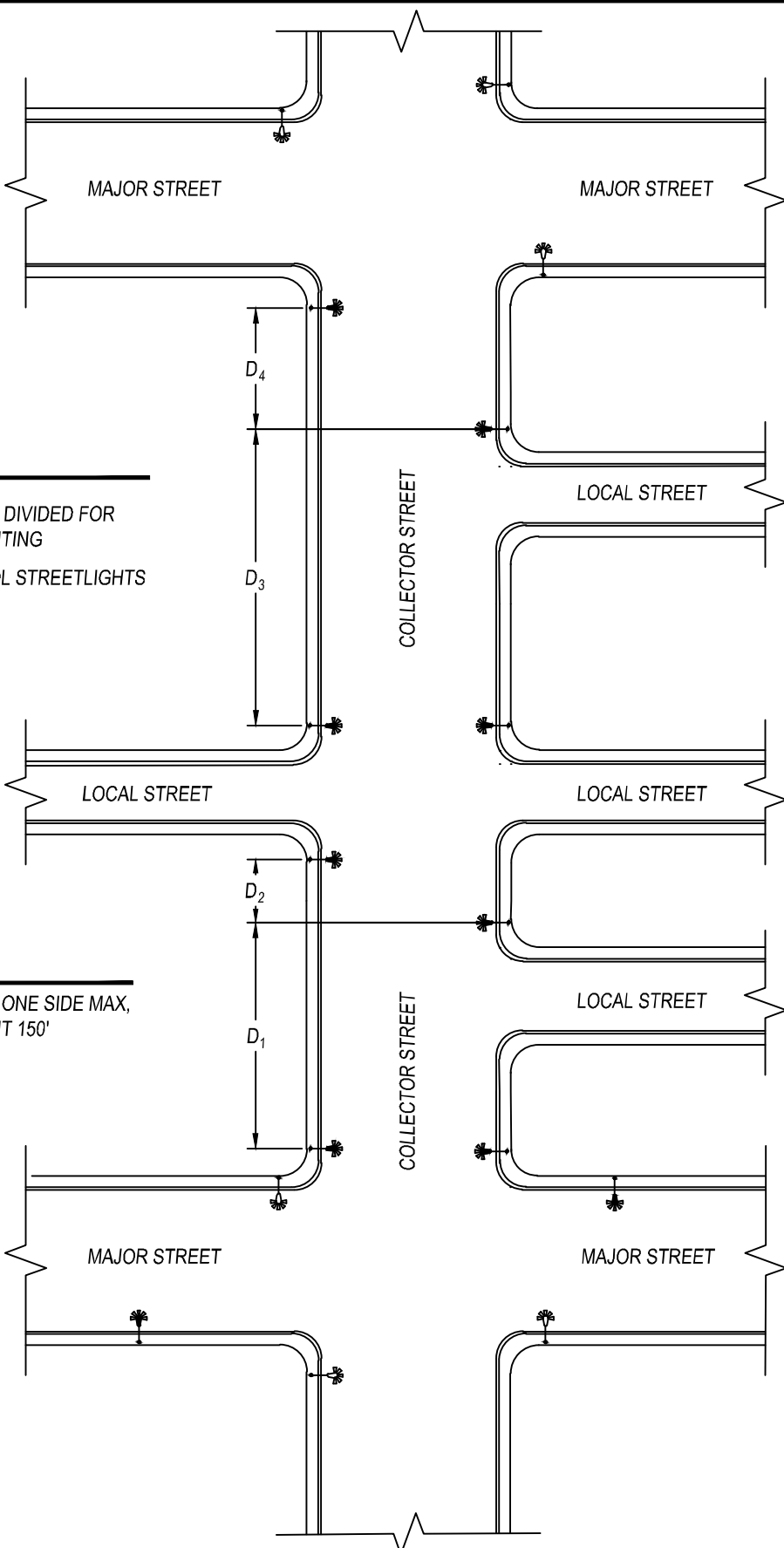

LEGEND

D_n = DISTANCE TO BE DIVIDED FOR MID-BLOCK LIGHTING
 * → DESIGN CONTROL STREETLIGHTS

NOTES:

STAGGER OR ALL ON ONE SIDE MAX, SPACING UNIT TO UNIT 150'



CITY COUNCIL APPROVAL: 01/24/2023
 APPROVED BY CITY ENGINEER
 APPROVED BY PUBLIC WORKS DIRECTOR

**STREETLIGHT PLACEMENT -
 COLLECTOR STREET**
PUBLIC IMPROVEMENT STANDARDS

E-8		
REVISIONS		
NAME	BY	DATE

LEGEND

D_n = DISTANCE TO BE DIVIDED FOR
MID-BLOCK LIGHTING

 DESIGN CONTROL STREETLIGHTS

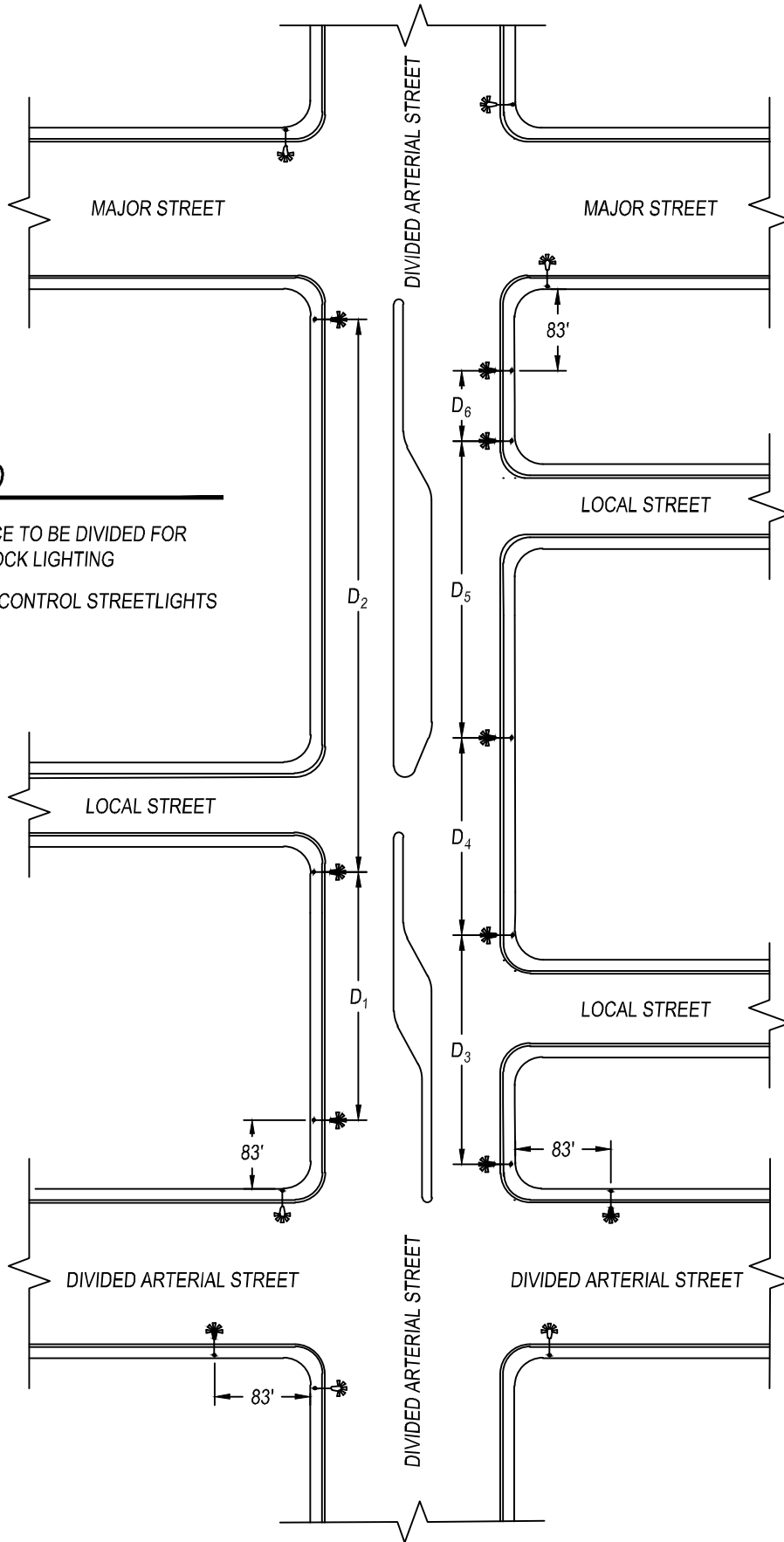

CITY COUNCIL APPROVAL: 01/24/2023

APPROVED BY CITY ENGINEER

APPROVED BY PUBLIC WORKS DIRECTOR

**STREETLIGHT PLACEMENT -
DIVIDED ARTERIAL STREETS**

PUBLIC IMPROVEMENT STANDARDS

E-9

REVISIONS

NAME	BY	DATE

CITY OF DINUBA LANDSCAPE DESIGN & CONSTRUCTION STANDARDS

SOIL MODIFICATION

1. Soil samples shall be taken by the Contractor and recommendations from the laboratory shall be provided to the City for their approval & records.
2. Certified compost shall be installed to a depth of 12".
3. The finished grade of all planting areas shall be between 1-2" below the adjacent pavement after settlement.
4. The Contractor shall provide all product delivery receipts of the amendments for their records.

IRRIGATION

1. The backflow prevention device shall be a Zurn 375 XLB or approved equal and located in a green strong box low profile expanded metal cage or approved equal with a freeze blanket. Backflow prevention device shall be installed on a 4" thick concrete pad. Galvanized/metal pipe shall be wrapped with a 10 mil pipe wrap to prevent corrosion.
2. The booster pump (if required) shall be single phase 230 power.
3. A water hammer arrestor shall be located between the backflow prevention device and master valve or booster pump and master valve whichever is applicable.
4. The master valve shall be a Hunter ICV normally open irrigation valve or approved equal.
5. The flow sensor shall be a CST T Series or approved equal.
6. Hydrometers (flow sensor/master valve) shall be normally open. Confirm with the controller manufacturer regarding the register output (photo diode vs. reed switch).
7. Irrigation systems with more than 12 zones shall have a Amiad disk filter with a minimum 200 mesh screen installed after the backflow prevention device and before the flow sensor and master valve.
8. The irrigation mainline shall be Sch. 40 PVC for all pipes less than 2.5" in size. For pipes larger than 2.5" it shall be Class 200 bell gasketed. 1-1/4" pipe is excluded on all projects.
9. Lateral line pipes shall be Class 200 for all sizes. 1-1/4" pipe is excluded on all projects.
10. Irrigation locator tape shall be placed six inches (6)" directly above the mainline for its entire run.
11. All irrigation wire shall be located in 1.5" Sch. 40 PVC electrical conduit.
12. Irrigation wire shall be 2-wire that is compatible with the irrigation controller manufacturer.
13. All irrigation wire connections shall be made with 3M DBR/Y-6 grease packs or approved equal.
14. Irrigation mainline and main lateral line headers shall be located no further than two feet (2') from the adjacent pavement. If the planting area is less than six feet (6') the mainline and main lateral line header shall be located no further than one foot (1') from adjacent pavement.
15. All mainline changes in direction shall be reinforced with thrust blocks.
16. All irrigation piping located under pavement shall be placed in Sch. 40 PVC two times the diameter of the pipe being sleeved. Sleeving under vehicular paving shall be to a depth of two feet (2') below the top of pavement and sleeving under pedestrian paving shall be to a depth of one foot (1') below the top of pavement. All sleeving shall extend one foot (1') past the edge of pavement.
17. Resilient wedge cast iron gate valves with a square operating nut shall be located on the mainline system where there is a tee in the irrigation mainline or prior to the mainline crossing vehicular pavement.
18. Hunter 1" locking quick coupler valves or approved equal shall be located every five hundred feet (500') on the mainline eighteen inches (18") off of the mainline,
19. Remote control irrigation valves shall be Hunter 1" ICV's or approved equal with a Sch. 80 tru-union ball valve on the inflow side and a Sch. 80 union on the outflow side.
20. All non-overhead remote control irrigation valves shall have a Rainbird XCZ-PRB-200-COM pressure regulator and filter or approved equal installed on the outflow side of the remote control irrigation valve. If a mainline disk filter is installed only a 30 psi pressure regulator shall be installed on each non overhead irrigation valve.
21. All irrigation valves, surge arrestors, quick couplers, gate valves, flow sensors, master valves, filter/pressure regulators, pull boxes and mainline stub outs shall be located in tan valve boxes. Quick couplers and pull boxes shall be located in circular valve boxes. All other equipment shall be located in rectangular valve boxes. The boxes shall be located on four (4) bricks and have 1/4" welded wire mesh placed at the bottom with 2" of pea gravel or approved equal installed. All valve boxes shall be branded.



CITY COUNCIL APPROVAL: 01/24/2023

[Signature]
APPROVED BY CITY ENGINEER

[Signature]
APPROVED BY PUBLIC WORKS DIRECTOR

LANDSCAPE DESIGN & CONSTRUCTION STANDARDS

PUBLIC IMPROVEMENT STANDARDS

L-1

REVISIONS		
NAME	BY	DATE

CITY OF DINUBA LANDSCAPE DESIGN & CONSTRUCTION STANDARDS

22. Trees between 5 gallons and 24" box shall be installed with one (1) Rainbird 1400 series PCB .25 gallon per minute flood bubbler. 36" box trees shall be installed with shall be irrigation with two (2) Rainbird 1400 series PCB .25 gallon per minute flood bubbler or approved equal.
23. Shrubs and vines shall be irrigated with one (1) Salco 2GPH emitter or approved equal for one (1) and five (5) gallon plants. Two (2) Salco 2GPH emitters or approved equal for shrubs 15 gallon and larger. Emitters shall be installed on Hunter 1/2" x 12" swing joints or approved equal.
24. Active turf play areas shall be irrigated with Hunter MP rotators on PRS 40 bodies or Hunter I-20's on Hunter 12" swing joints or an approved equal.
25. All vine and shrub irrigation zones shall have one (1) GPH flush/indicator valve on a Rainbird six inch (6") pop up or approved equal installed on either end of the irrigation zone.
26. The irrigation controller shall be a Hunter stainless steel wall mounted ACC2 2-wire decoder controller or approved equal. Pedestal options are acceptable only in the event a wall mounting is not available.
27. The irrigation controller shall be grounded according to the controller manufacturer's specifications and recommendations.
28. The irrigation controller shall be certified after installation by the controller manufacturer or distributor indicating the controller set up meets the following minimum:
 - Flows for each irrigation zone has been learned.
 - Like zones have been placed in the same program.
 - Irrigation schedule has been programmed to run multiple zones based on the design parameters.
 - Flow management has been set up to turn off the system an notify the City and installing Contractor of an unexpected flow or high flow.
 - Communication to the controller manufacturer's online management platform has been set up and both the City and installing Contractor have access (if applicable).

PLANTING

1. 80% of all plants shall on the plans shall considered low or very low under the most current WUCOLS water use for the City of Dinuba. 20% of the plant material may be medium water use.
2. Shrubs shall be designed to have a density of 20 plants per 1,000 sq. feet.
3. All trees shall be a minimum of 15 gallon in size, vines shall be 5 gallon in size and shrubs 1 gallon in size. The maximum size for trees shall be 36" box and 15 gallon for shrubs.
4. Plant substitutions are allowed based on availability with written approval from the City and Architect of Record.
5. All plant material shall be reviewed and accepted by the City.
6. All trees located within ten feet (10') of paving, curb or wall shall have a 12" root barrier by Deep Root or approved equal installed five feet (5') in either direction.
7. All trees shall be staked with one (1) 10' Reddy Stake and secured with rubber strap.
8. Active play turf shall be Black Jack Bermuda from seed or approved equal.
9. All planting areas shall be mulched with a five (5") thick layer of 'Screened Orchard' mulch.
10. All City maintained landscape areas shall be separated with an 8" concrete mow curbs delineating different landscape & lighting districts, phases of landscape lighting districts and/or City and Non-City owner property.
11. The Contractor shall provide to the City copies for their records of the plant material invoices and delivery receipts of the mulch.

SPECIALTY ITEMS

1. All playground material shall have twelve inches (12") of certified playground mulch installed after settling.
2. All playground equipment installed shall be certified by a 3rd party.
3. Copies of the 3rd party certification shall be provided to the City for their records.



CITY COUNCIL APPROVAL: 01/24/2023

[Signature]
APPROVED BY CITY ENGINEER

[Signature]
APPROVED BY PUBLIC WORKS DIRECTOR

LANDSCAPE DESIGN & CONSTRUCTION STANDARDS

PUBLIC IMPROVEMENT STANDARDS

L-2

REVISIONS		
NAME	BY	DATE

CITY OF DINUBA LANDSCAPE DESIGN & CONSTRUCTION STANDARDS

CITY REQUIRED INSPECTIONS

1. Mainline & lateral line sleeving.
2. Mainline and lateral line installation.
3. Mainline pressure test shall be performed to 150 psi over an 8 hour period with a loss no more of 5psi.
4. Plant material.
5. Irrigation system operation prior to mulching.
6. Project completion to enter into the maintenance period.
7. Project completion at the end of the maintenance period.
8. The City shall provide a letter in writing to the Contractor indicating the entrance into the maintenance period and a letter in writing showing a completion of the maintenance period.

CITY REQUIRED MAINTENANCE PERIOD

1. The City's maintenance period for landscape and lighting districts shall be one (1) year from the date of receiving a notice of completion in writing from the City.
2. The Contractor is required to inspect the site a minimum of one (1) time each week for the duration of the maintenance period.



CITY COUNCIL APPROVAL: 01/24/2023

[Signature]
APPROVED BY CITY ENGINEER

[Signature]
APPROVED BY PUBLIC WORKS DIRECTOR

LANDSCAPE DESIGN &
CONSTRUCTION STANDARDS

PUBLIC IMPROVEMENT STANDARDS

L-3

REVISIONS		
NAME	BY	DATE

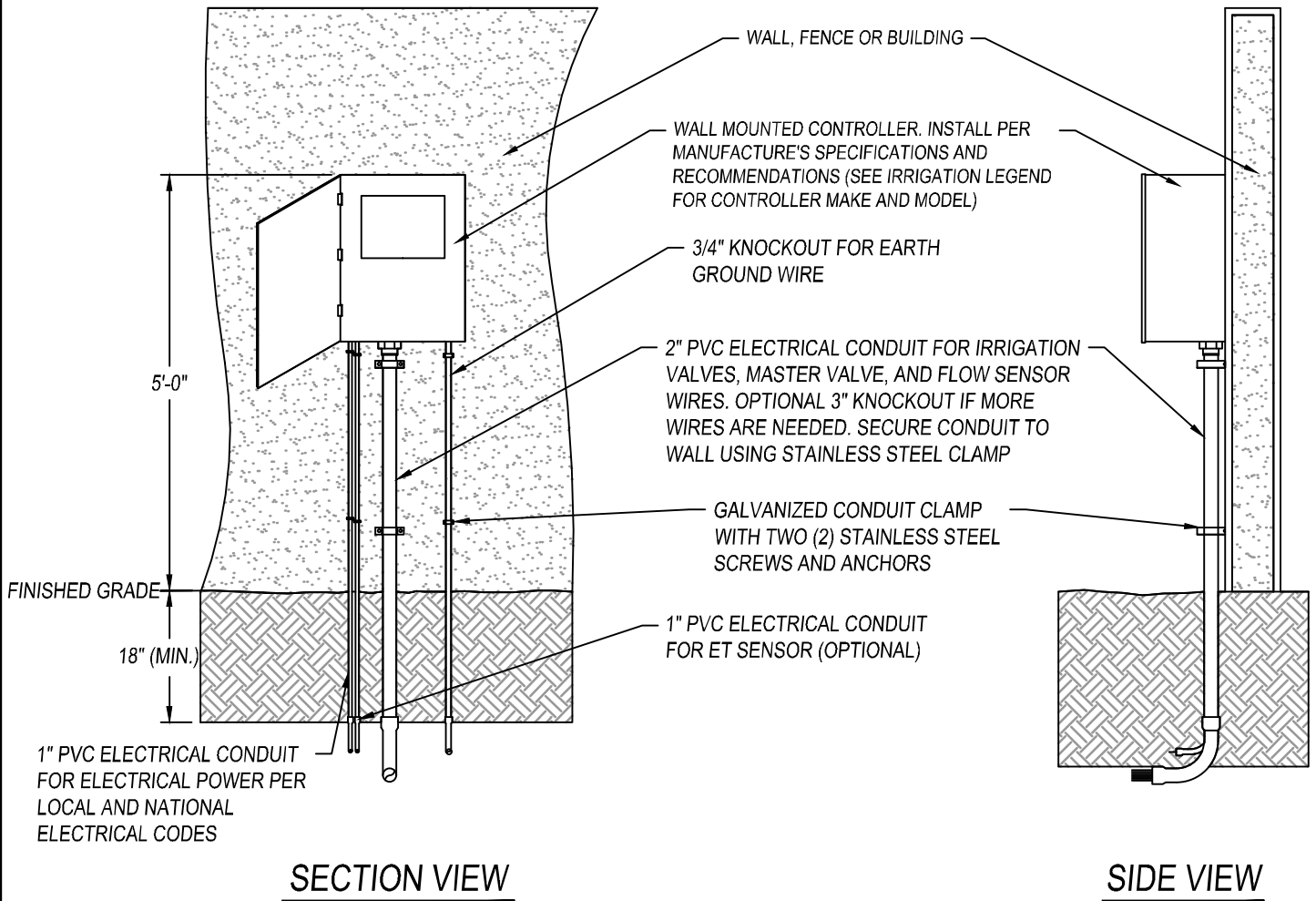

SECTION VIEW

SIDE VIEW

NOTES:

1. COMMON AND CONTROLLER WIRE TO BE BUNDLED USING ELECTRICAL TAPE AT 10'-0" ON CENTER.
2. GROUNDING RODS SHALL BE LOCATED BETWEEN 8'- 0" TO 12'- 0" AWAY FROM THE CONTROLLER. GROUNDING RODS SHALL BE 3/8" IN DIAMETER X 8' IN LENGTH. CONNECT THE GROUNDING ROD TO THE CONTROLLER USING 6 GAUGE BARE COPPER WIRE OR PER THE MANUFACTURER'S SPECIFICATIONS.SEE GROUNDING ROD DETAIL.
3. GROUNDING ROD SHALL NOT BE LOCATED WITHIN THE SAME TRENCH AS THE IRRIGATION WIRE.
4. ET STATION SHALL BE INSTALLED NO FURTHER THAN 90' AWAY FROM THE CONTROLLER AND A MINIMUM OF 15' OFF OF THE GROUND, OUT FROM UNDER ANY OVERHEAD OBSTRUCTIONS SUCH AS, BUT NOT LIMITED TO, BUILDING OVERHANGS, TREES, OR UTILITIES.



CITY COUNCIL APPROVAL: 01/24/2023

[Signature]
APPROVED BY CITY ENGINEER

[Signature]
APPROVED BY PUBLIC WORKS DIRECTOR

WALL MOUNTED CONTROLLER

PUBLIC IMPROVEMENT STANDARDS

L-4		
REVISIONS		
NAME	BY	DATE

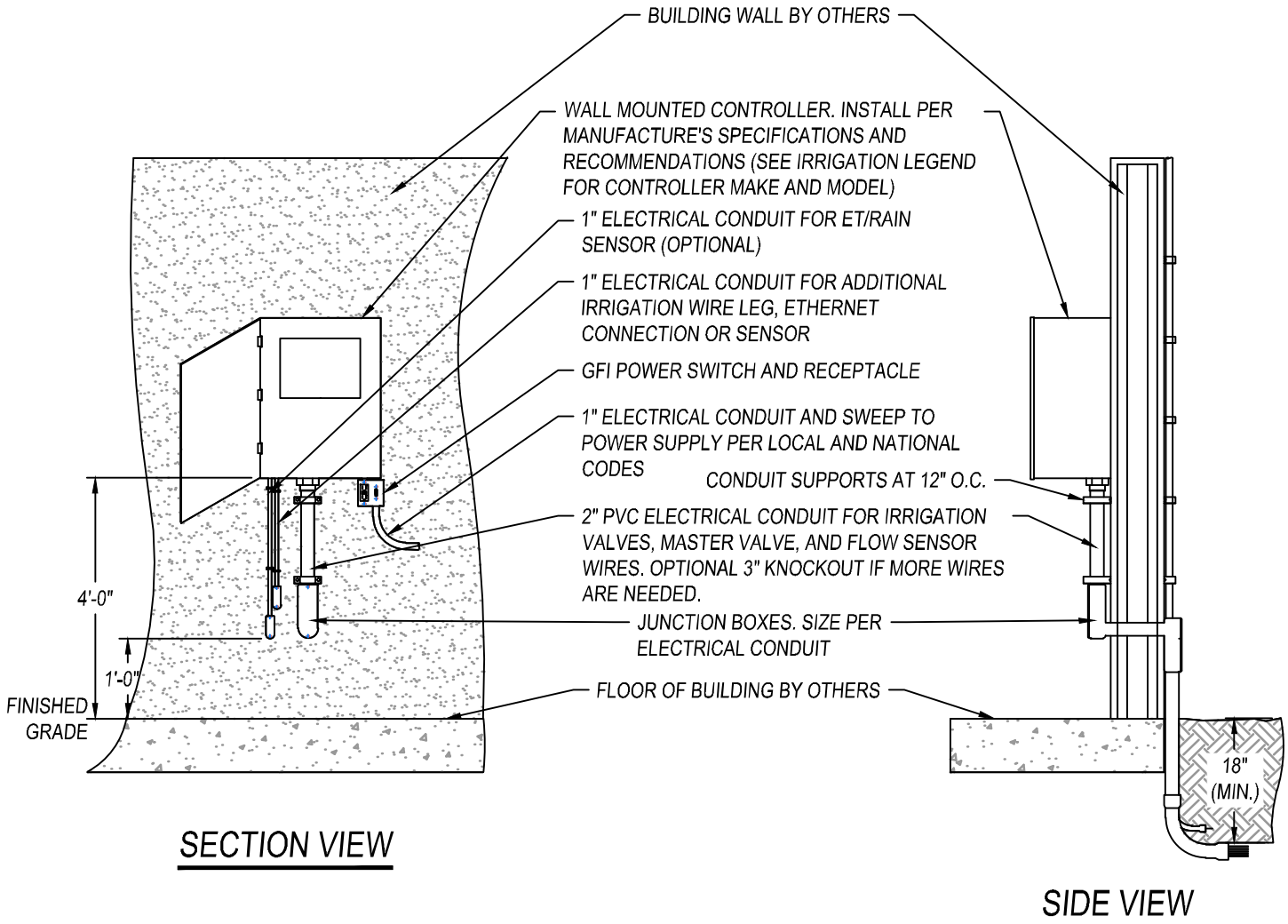

NOTES:

1. COMMON AND CONTROLLER WIRE TO BE BUNDLED USING ELECTRICAL TAPE AT 10'-0" ON CENTER.
2. CONTROLLER SHALL BE GROUNDED TO EITHER THE BUILDING OR EXTERIOR PLANTING AREA PER ALL LOCAL, STATE AND NATIONAL ELECTRIC CODES.
3. EXTERIOR GROUNDING SHALL BE GROUNDING RODS. GROUNDING RODS SHALL BE LOCATED BETWEEN 8'-0" TO 12'-0" AWAY FROM THE CONTROLLER. GROUNDING RODS SHALL BE 3/8" IN DIAMETER X 8' IN LENGTH. CONNECT THE GROUNDING ROD TO THE CONTROLLER USING 6 GAUGE BARE COPPER WIRE OR PER THE MANUFACTURER'S SPECIFICATIONS. SEE GROUNDING ROD DETAIL.
4. GROUNDING ROD SHALL NOT BE LOCATED WITHIN THE SAME TRENCH AS THE IRRIGATION WIRE.
5. ALL CONDUIT ABOVE GRADE SHALL BE STEEL.
6. EACH CONDUIT REQUIRES A J-BOX ON THE INTERIOR AND EXTERIOR OF THE BUILDING.
7. ALL INTERIOR CONDUIT AND J-BOXES SHALL BE STEEL.
8. ALL EXTERIOR J-BOXES SHALL BE WEATHER PROOF.
9. ET STATION SHALL BE INSTALLED NO FURTHER THAN 90' AWAY FROM THE CONTROLLER AND A MINIMUM OF 15' OFF OF THE GROUND, OUT FROM UNDER ANY OVERHEAD OBSTRUCTIONS SUCH AS, BUT NOT LIMITED TO, BUILDING OVERHANGS, TREES, OR UTILITIES.



CITY COUNCIL APPROVAL: 01/24/2023

APPROVED BY CITY ENGINEER

APPROVED BY PUBLIC WORKS DIRECTOR

**WALL MOUNTED
CONTROLLER-INTERIOR**

PUBLIC IMPROVEMENT STANDARDS

L-5		
REVISIONS		
NAME	BY	DATE

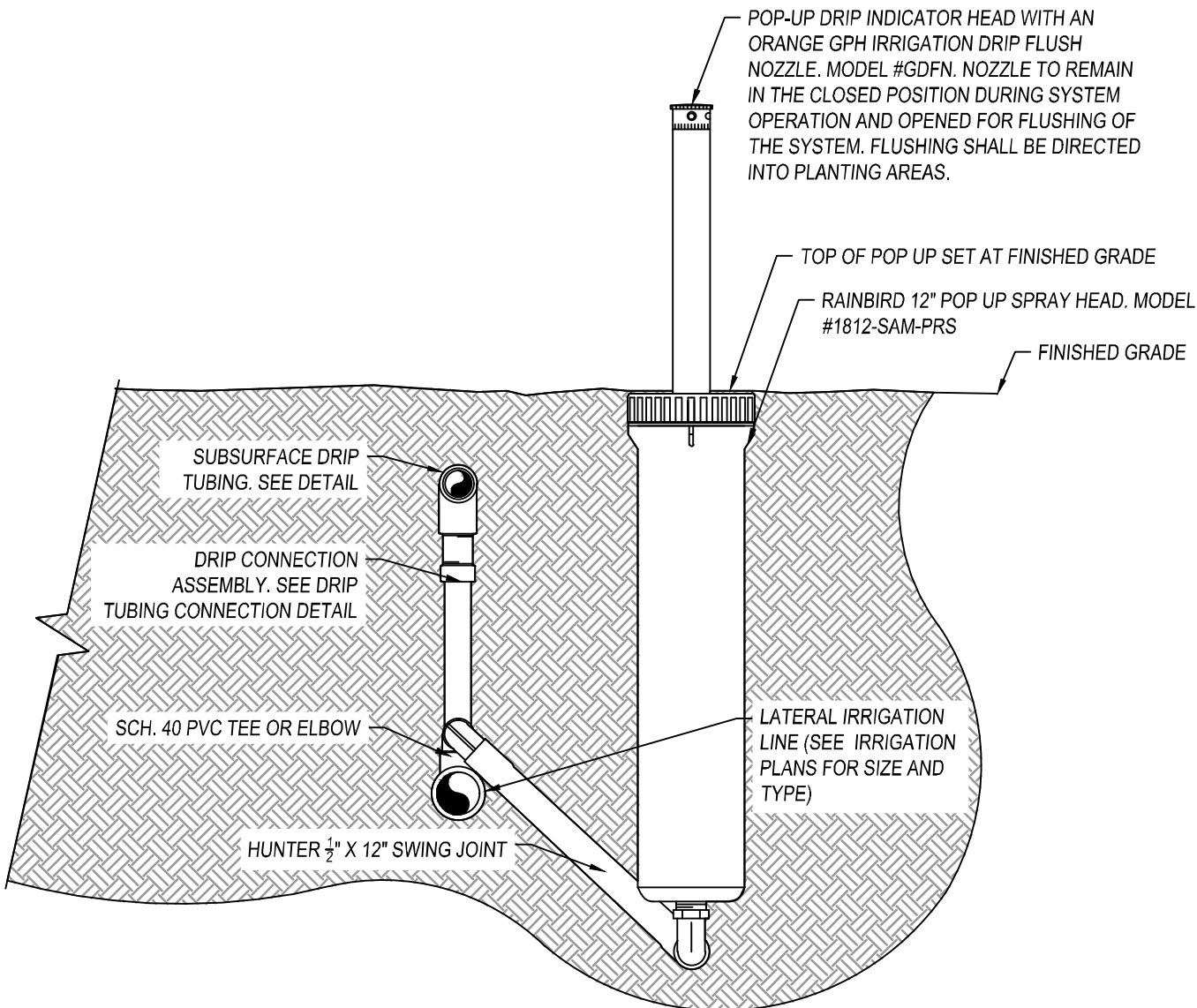

NOTES:

1. INSTALL 12" OFF ANY ADJACENT PAVEMENT IN PLANTING AREAS.
2. CONTRACTOR SHALL SETTLE SOIL AROUND THE POP UP AFTER INSTALLATION.
3. ALL POP UP SPRAY HEADS SHALL HAVE CHECK VALVES.
4. ALL SCH. 40 PVC TO SCH. 80 PVC CONNECTIONS SHALL BE MADE USING TEFLON TAPE.



CITY COUNCIL APPROVAL: 01/24/2023

[Signature]
APPROVED BY CITY ENGINEER

[Signature]
APPROVED BY PUBLIC WORKS DIRECTOR

DRIP FLUSH INDICATOR

PUBLIC IMPROVEMENT STANDARDS

L-6		
REVISIONS		
NAME	BY	DATE

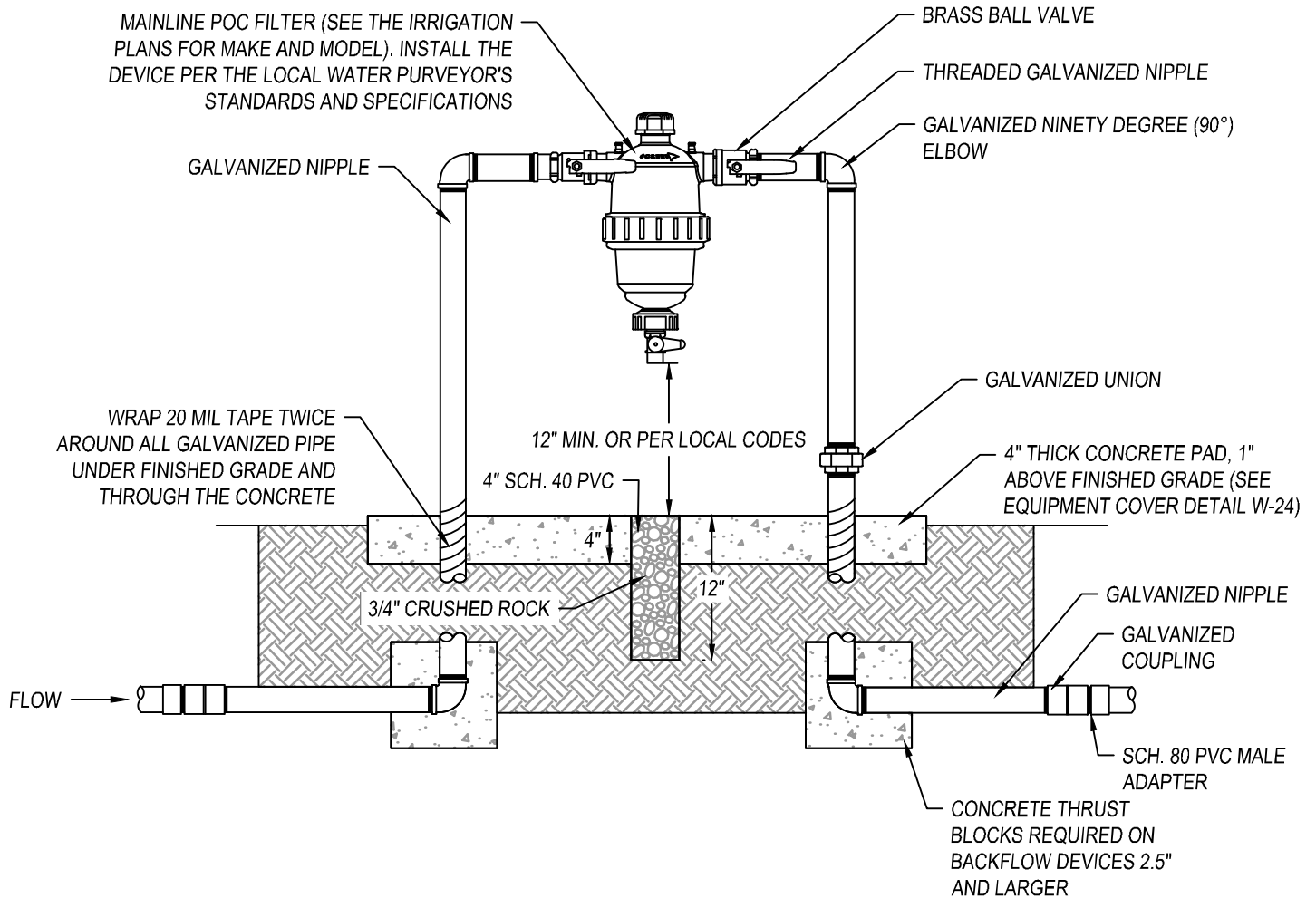

NOTES:

1. ALL ASSEMBLY PARTS (THREADED NIPPLES, FITTINGS, ETC.) SHALL BE GALVANIZED OR BRASS PER LOCAL CODES AND REQUIREMENTS.
2. GALVANIZED NIPPLE SHALL EXTEND 12" PAST THE EDGE OF THE CONCRETE FOOTING.
3. SCH. 80 PVC MALE ADAPTER SHALL BE USED IN CONNECTION FROM GALVANIZE TO THE MAINLINE.
4. MAINLINE POINT OF CONNECTION (POC) FILTER SHALL BE LOCATED IN PLANTING AREA UNLESS APPROVED BY OWNER'S REPRESENTATIVE.
5. SEE IRRIGATION LEGEND FOR MAINLINE POC FILTER CAGE MAKE AND MODEL. SEE BACKFLOW CAGE DETAIL FOR INSTALLATION.
6. ALL GALVANIZED CONNECTIONS SHALL TO BE MADE USING PIPE THREAD SEALANT. ALL SCH. 80 PVC TO GALVANIZED CONNECTIONS TO BE MADE USING TEFLON TAPE.



CITY COUNCIL APPROVAL: 01/24/2023

APPROVED BY CITY ENGINEER

APPROVED BY PUBLIC WORKS DIRECTOR

MAINLINE POINT OF CONNECTION (POC) FILTER

PUBLIC IMPROVEMENT STANDARDS

L-7

REVISIONS

NAME	BY	DATE

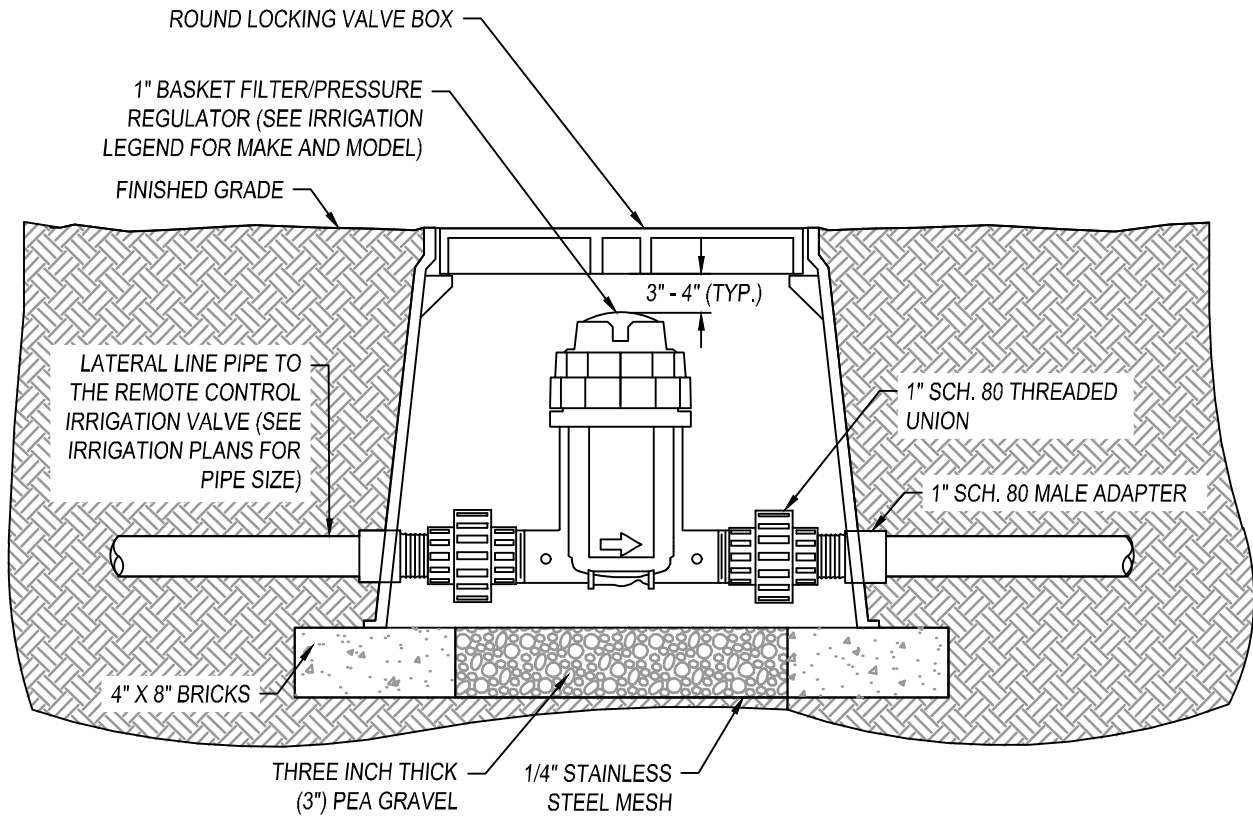

NOTES:

1. CONTRACTOR SHALL THREADED FITTINGS WITH NO MORE THAN TWO (2) WRAPS OF TEFLON TAPE OR MONSTER TAPE.
2. PRIOR TO THE INSTALLATION OF THE DRIP FILTER/PRESSURE REGULATOR, THE CONTRACTOR SHALL FLUSH THE LINES A MINIMUM OF TWO (2) TIMES TO REMOVE ALL GLUE, TAPE AND/OR DEBRIS FROM THE MAINLINE AND LATERAL LINES.
3. AFTER THE INSTALLATION OF THE DRIP FILTER/PRESSURE REGULATOR, THE CONTRACTOR SHALL CAP ALL LATERAL LINES DOWNSTREAM OF THE FILTER AND PRESSURIZE THE IRRIGATION SYSTEM AND VERIFY THERE ARE NO LEAKS OR BREAKS.



CITY COUNCIL APPROVAL: 01/24/2023
 APPROVED BY CITY ENGINEER
 APPROVED BY PUBLIC WORKS DIRECTOR

1" BASKET DRIP FILTER/PRESSURE REGULATOR

PUBLIC IMPROVEMENT STANDARDS

L-8

REVISIONS

NAME	BY	DATE

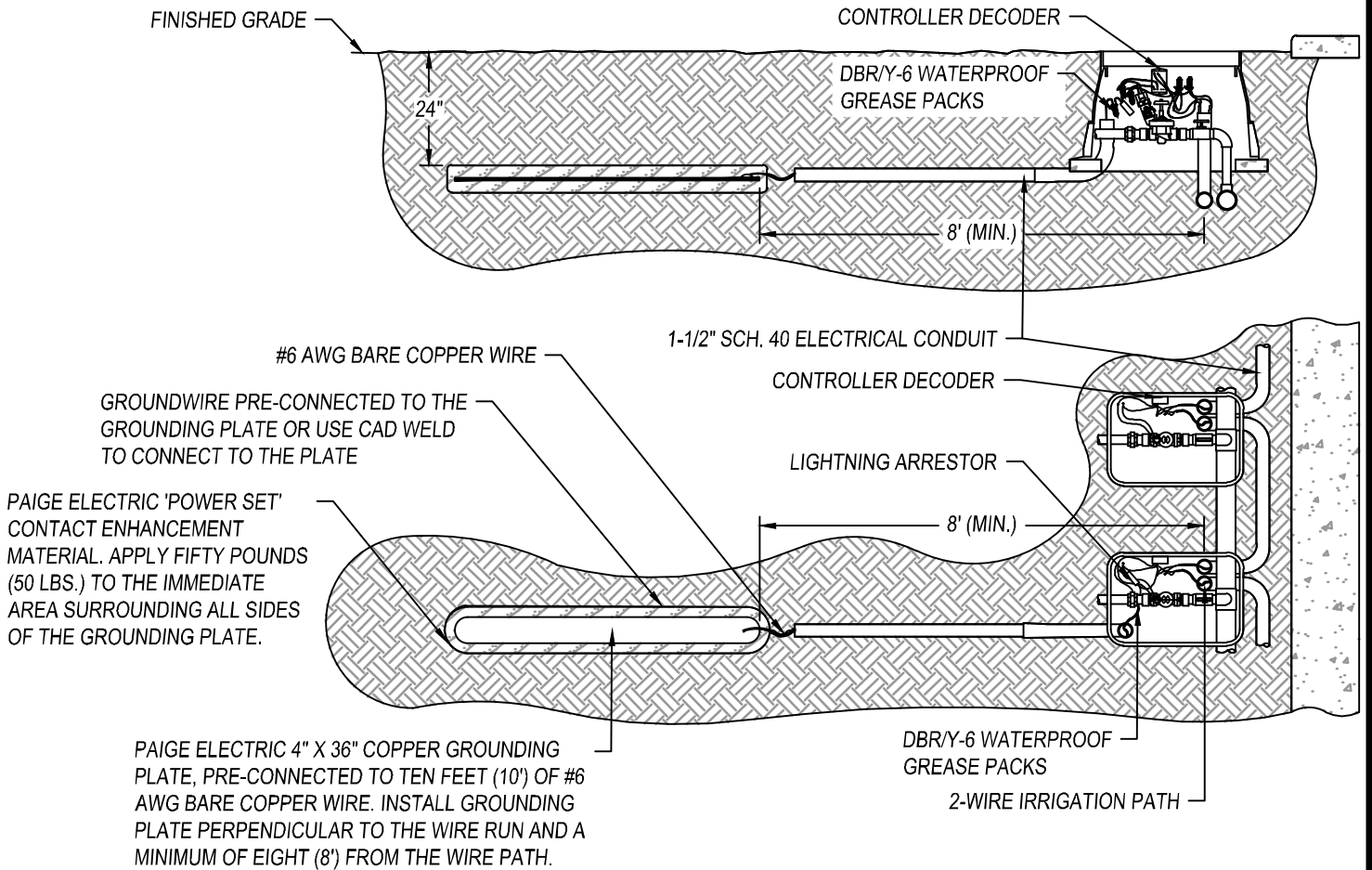

NOTES:

1. DECODER SYSTEM GROUNDING SHALL BE PER THE CONTROLLER MANUFACTURER'S SPECIFICATIONS AND RECOMMENDATIONS OR AT A MINIMUM OF EVERY FIVE HUNDRED FEET (500') OF THE IRRIGATION 2-WIRE PATH RUN AND IRRIGATION 2-WIRE PATH SPURS OF FIFTY FEET (50') OR GREATER.
2. ALL SCH. 40 ELECTRICAL CONDUIT OPENINGS SHALL BE FILLED WITH A FOAM SEALANT AFTER GROUNDING INSTALLATION PRIOR TO BACKFILLING.
3. ACCEPTABLE EARTH GROUND SHALL NOT EXCEED 10 OHMS.
4. GROUNDING TESTING SHALL BE PERFORMED BY A CERTIFIED 3RD PARTY AND DOCUMENTATION OF GROUNDING CERTIFICATION SHALL BE PROVIDED TO THE OWNER AND OWNER'S REPRESENTATIVE PRIOR TO PROJECT ACCEPTANCE AND BEGINNING OF THE MAINTENANCE PERIOD.
5. SEE 2-WIRE IRRIGATION CONNECTION DETAIL FOR FURTHER INFORMATION.
6. SEE 2-WIRE REMOTE CONTROL IRRIGATION VALVE DETAIL FOR FURTHER INFORMATION.
7. CONTRACTOR SHALL INCLUDE IN THEIR BID THE ADDITION OF ONE (1) COPPER GROUNDING PLATE AND #6 AWG BARE COPPER WIRE FOR CONTROLLER GROUNDING AS NECESSARY.



CITY COUNCIL APPROVAL: 01/24/2023

[Signature]
APPROVED BY CITY ENGINEER

[Signature]
APPROVED BY PUBLIC WORKS DIRECTOR

GROUNDING PLATE AND LIGHTNING ARRESTOR

PUBLIC IMPROVEMENT STANDARDS

L-9

REVISIONS

NAME	BY	DATE

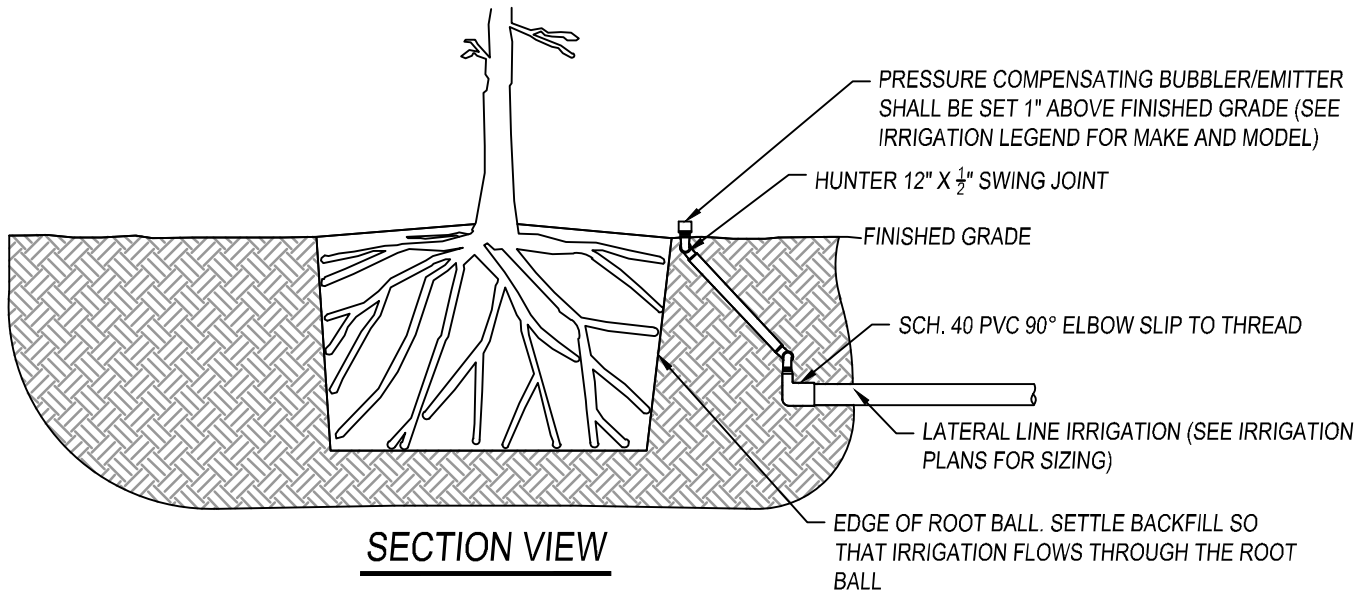

SECTION VIEW

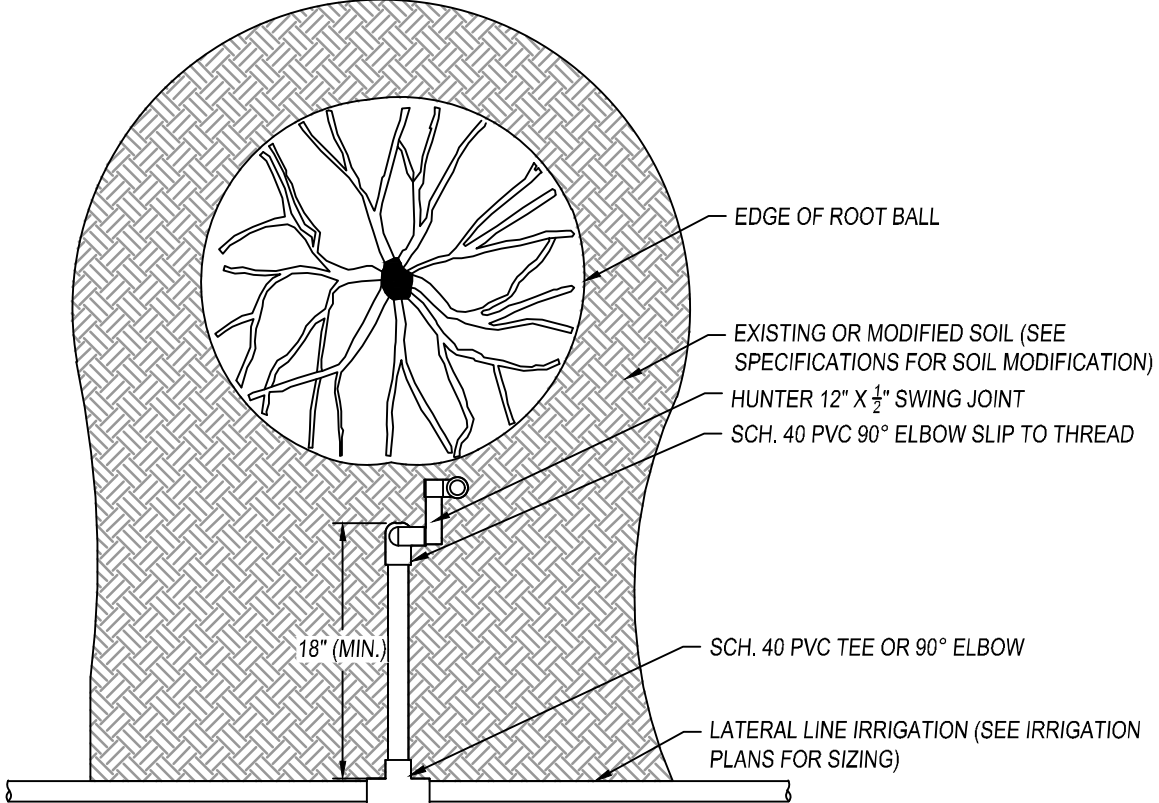

PLAN VIEW

NOTES:

1. ALL IRRIGATION FITTINGS SHALL BE SCH. 40 PVC UNLESS SPECIFIED OTHERWISE.
2. ALL THREADED CONNECTIONS FROM SCH. 40 TO SCH. 80 PVC SHALL BE MADE USING TEFLON TAPE.
3. CONTRACTOR SHALL SETTLE THE AREA AROUND THE BUBBLER AND EDGE OF THE ROOT BALL SO THAT ALL IRRIGATION FLOWS THROUGH THE ROOT BALL.



CITY COUNCIL APPROVAL: 01/24/2023
 APPROVED BY CITY ENGINEER
 APPROVED BY PUBLIC WORKS DIRECTOR

BUBBLER/EMITTER ON ROOT BALL LAYOUT
PUBLIC IMPROVEMENT STANDARDS

L-10		
REVISIONS		
NAME	BY	DATE

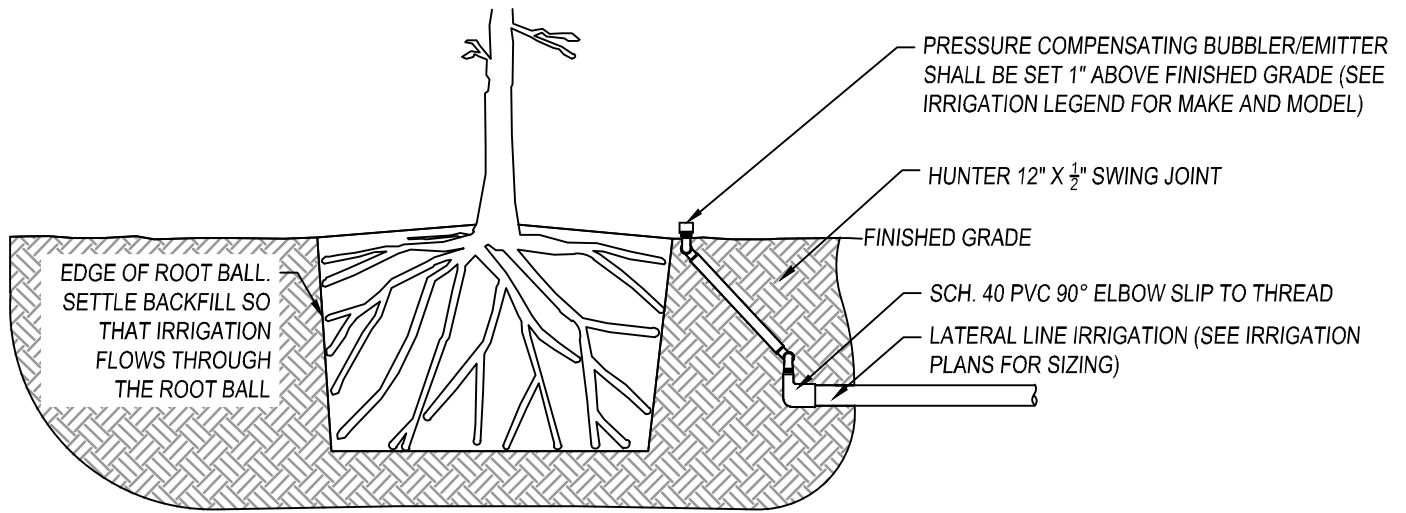

SECTION VIEW

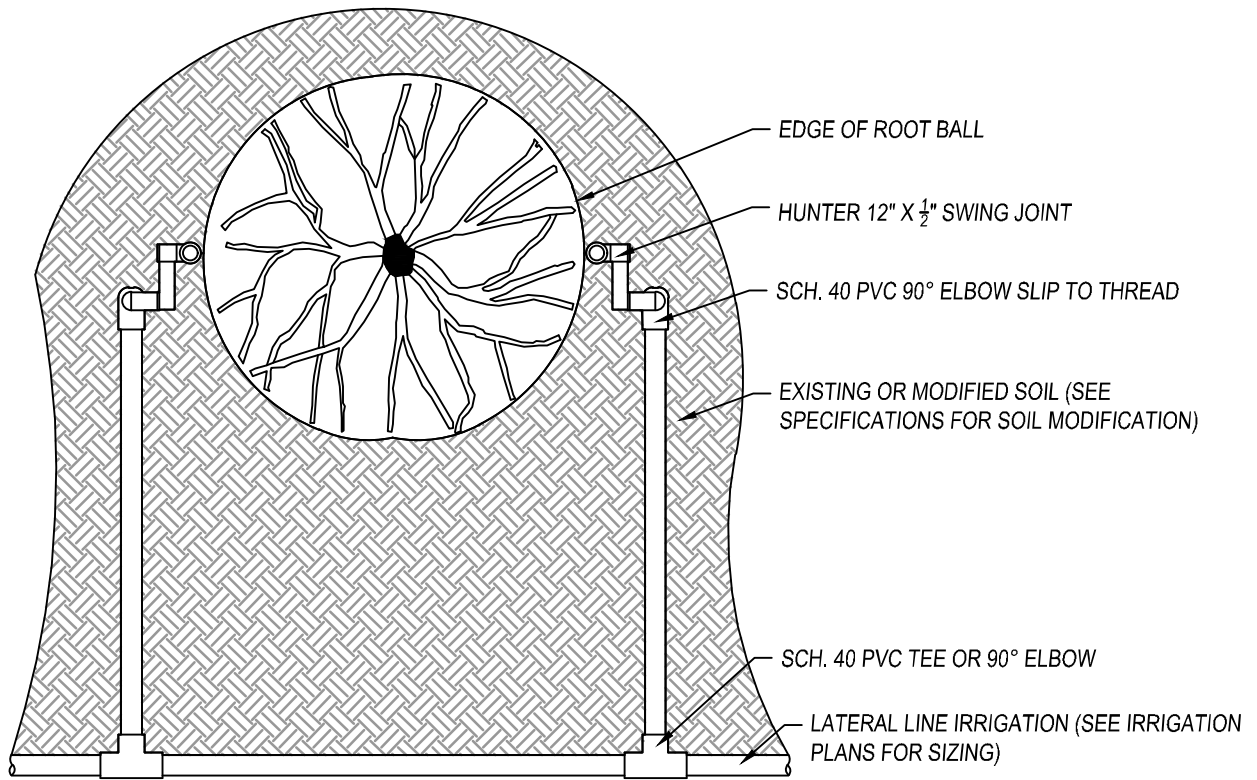

PLAN VIEW

NOTES:

1. ALL IRRIGATION FITTINGS SHALL BE SCH. 40 PVC UNLESS SPECIFIED OTHERWISE.
2. ALL THREADED CONNECTIONS FROM SCH. 40 TO SCH. 80 PVC SHALL BE MADE USING TEFLON TAPE.
3. CONTRACTOR SHALL SETTLE THE AREA AROUND THE BUBBLER AND EDGE OF THE ROOT BALL SO THAT ALL IRRIGATION FLOWS THROUGH THE ROOT BALL.



CITY COUNCIL APPROVAL: 01/24/2023

[Signature]
APPROVED BY CITY ENGINEER

[Signature]
APPROVED BY PUBLIC WORKS DIRECTOR

BUBBLERS/EMITTERS ON ROOT BALL

PUBLIC IMPROVEMENT STANDARDS

L-11		
REVISIONS		
NAME	BY	DATE

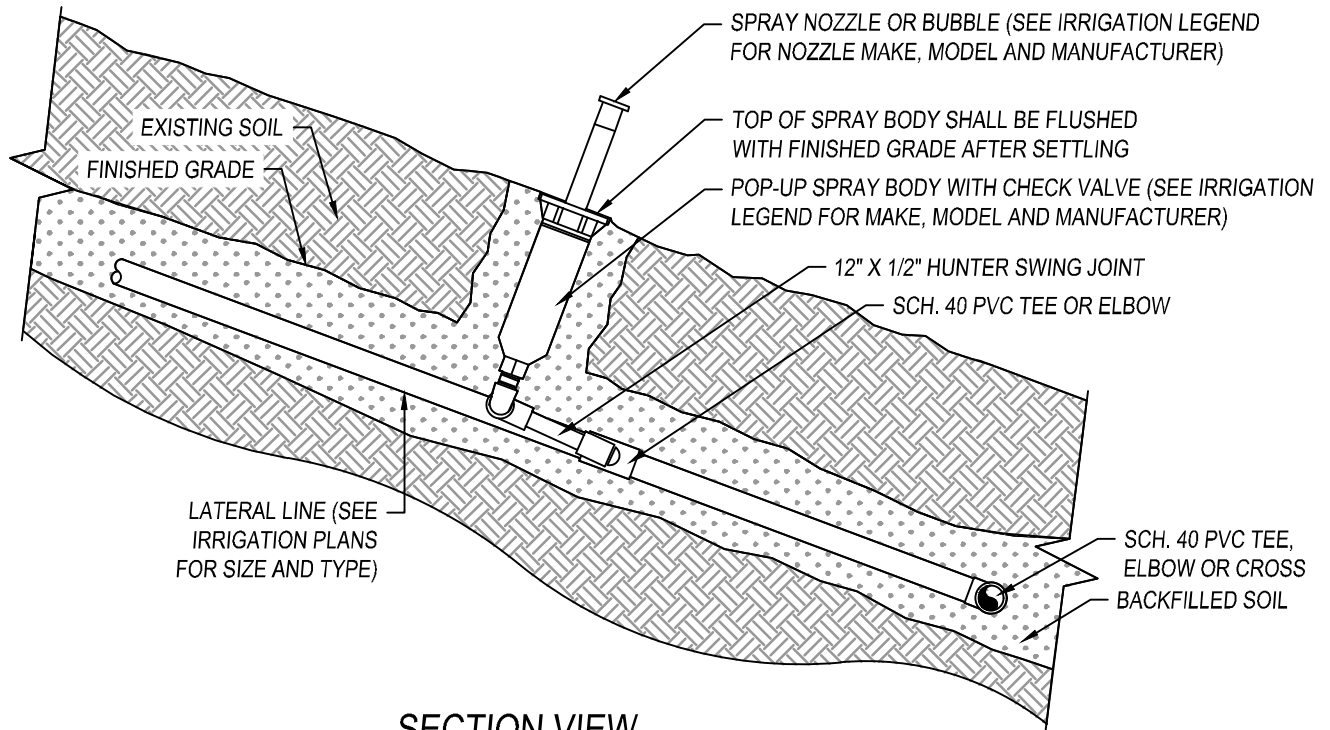

SECTION VIEW

NOTES:

1. ALL IRRIGATION FITTINGS UNLESS SPECIFIED OTHERWISE SHALL BE SCH. 40 PVC.
2. ALL POP-UP SPRAY BODIES SHALL BE INSTALLED WITH CHECK VALVES.
3. ELEVATION CHANGES GREATER THAN SEVEN (7') BETWEEN EACH HEAD SHALL HAVE AN ADDITIONAL CHECK VALVE OF THE SAME MANUF. AS THE POP-UP SPRAY BODY INSTALLED BETWEEN THE SWING JOINT AND POP-UP SPRAY BODY TO REDUCE RUNOFF.
4. PRIOR TO MULCHING THE CONTRACTOR SHALL SETTLE ALL OF THE SOIL IN THE IRRIGATION TRENCHES AND AROUND EACH EMITTER SO WATER FLOWS EVENLY THROUGH THE SOIL.
5. THE CONTRACTOR SHALL THOROUGHLY FLUSH THE LINES A MINIMUM OF THREE (3) TIMES PRIOR TO INSTALLING THE NOZZLE.



CITY COUNCIL APPROVAL: 01/24/2023

[Signature]
APPROVED BY CITY ENGINEER

[Signature]
APPROVED BY PUBLIC WORKS DIRECTOR

POP UP SPRAY HEAD ON SLOPE

PUBLIC IMPROVEMENT STANDARDS

L-12

REVISIONS

NAME	BY	DATE

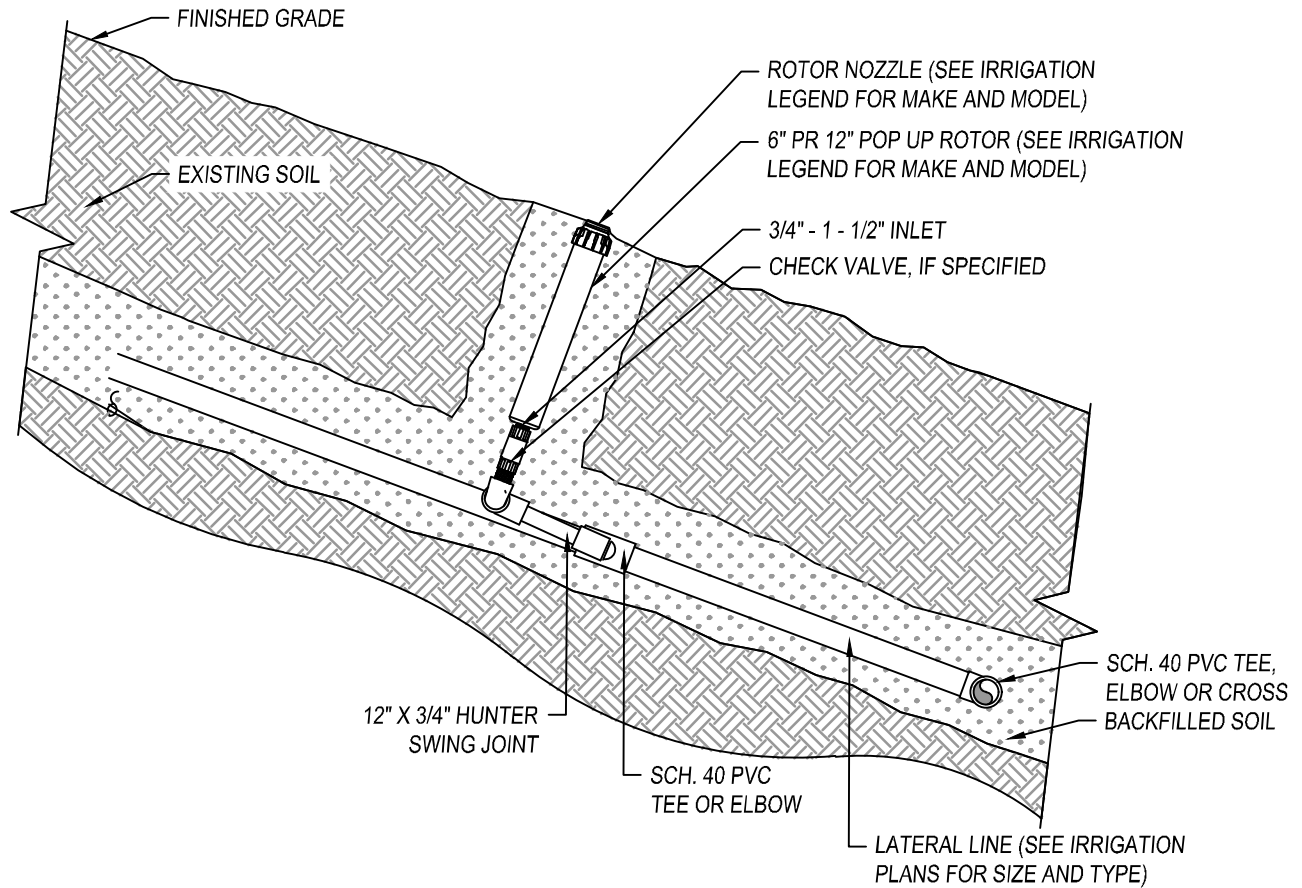

SECTION VIEW

NOTES:

1. ALL IRRIGATION FITTINGS UNLESS SPECIFIED OTHERWISE SHALL BE SCH. 40 PVC.
2. A SCH. 80 NIPPLE SHALL BE INSTALLED BETWEEN THE SWING JOINT AND CHECK VALVE SO THE TOP OF THE ROTOR IS FLUSH WITH FINISHED GRADE AS NEEDED.
3. ALL POP-UP ROTOR BODIES SHALL BE INSTALLED WITH CHECK VALVES.
4. ELEVATION CHANGES GREATER THAN SEVEN (7') BETWEEN EACH HEAD SHALL HAVE AN ADDITIONAL CHECK VALVE OF THE SAME MANUF. AS THE ROTOR SPRAY BODY INSTALLED BETWEEN THE SWING JOINT AND POP-UP SPRAY BODY TO REDUCE RUNOFF.
5. PRIOR TO MULCHING THE CONTRACTOR SHALL SETTLE ALL OF THE SOIL IN THE IRRIGATION TRENCHES AND AROUND EACH EMITTER SO WATER FLOWS EVENLY THROUGH THE SOIL.



CITY COUNCIL APPROVAL: 01/24/2023
 APPROVED BY CITY ENGINEER
 APPROVED BY PUBLIC WORKS DIRECTOR

ROTOR SPRAY HEAD ON SLOPE

PUBLIC IMPROVEMENT STANDARDS

L-13

REVISIONS

NAME	BY	DATE

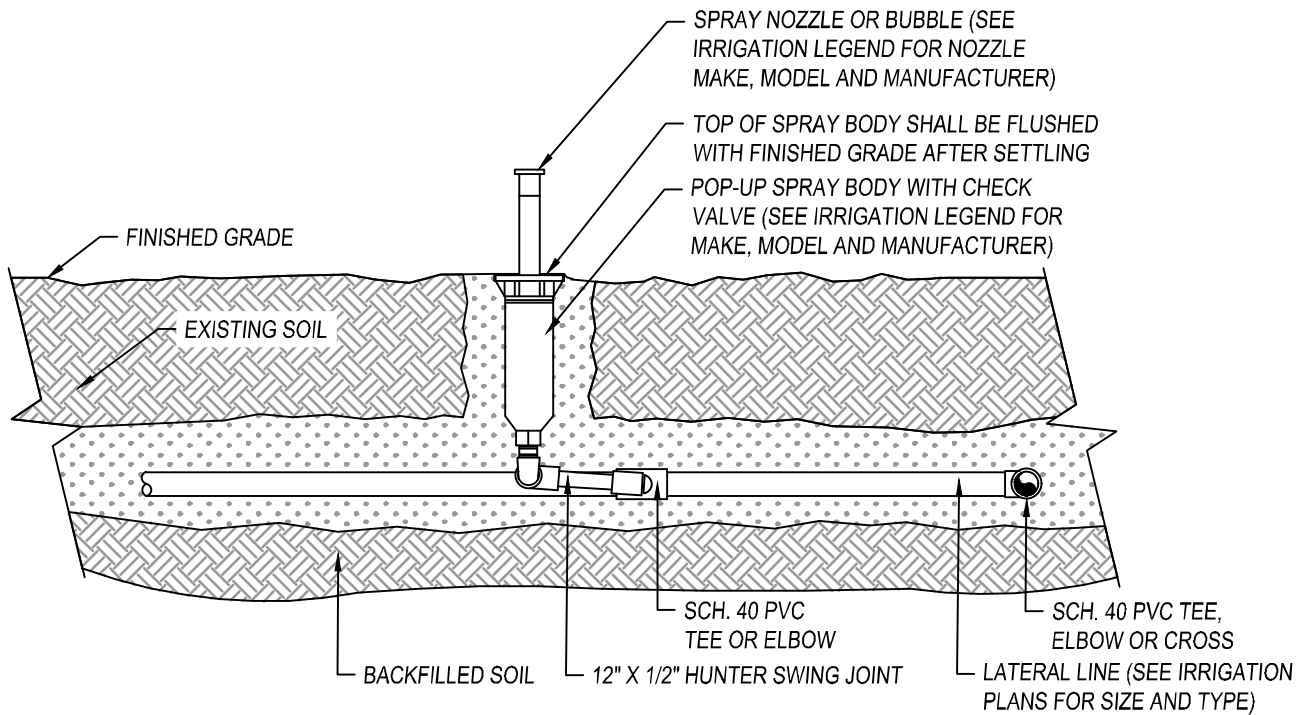

SECTION VIEW

NOTES:

1. ALL IRRIGATION FITTINGS UNLESS SPECIFIED OTHERWISE SHALL BE SCH. 40 PVC.
2. ALL POP-UP SPRAY BODIES SHALL BE INSTALLED WITH CHECK VALVES.
3. PRIOR TO INSTALLING THE NOZZLE, THE CONTRACTOR SHALL BLEED EACH NOZZLE TO REMOVE ANY DIRT, DEBRIS, GLUE OR TEFLON TAPE FROM THE IRRIGATION LINES.
4. PRIOR TO MULCHING THE CONTRACTOR SHALL SETTLE ALL OF THE SOIL IN THE IRRIGATION TRENCHES AND AROUND EACH EMITTER SO WATER FLOWS EVENLY THROUGH THE SOIL.
5. THE CONTRACTOR SHALL THOROUGHLY FLUSH THE LINES A MINIMUM OF THREE (3) TIMES PRIOR TO INSTALLING THE NOZZLE.



CITY COUNCIL APPROVAL: 01/24/2023

[Signature]
APPROVED BY CITY ENGINEER

[Signature]
APPROVED BY PUBLIC WORKS DIRECTOR

POP UP SPRAY HEAD

PUBLIC IMPROVEMENT STANDARDS

L-14

REVISIONS

NAME	BY	DATE

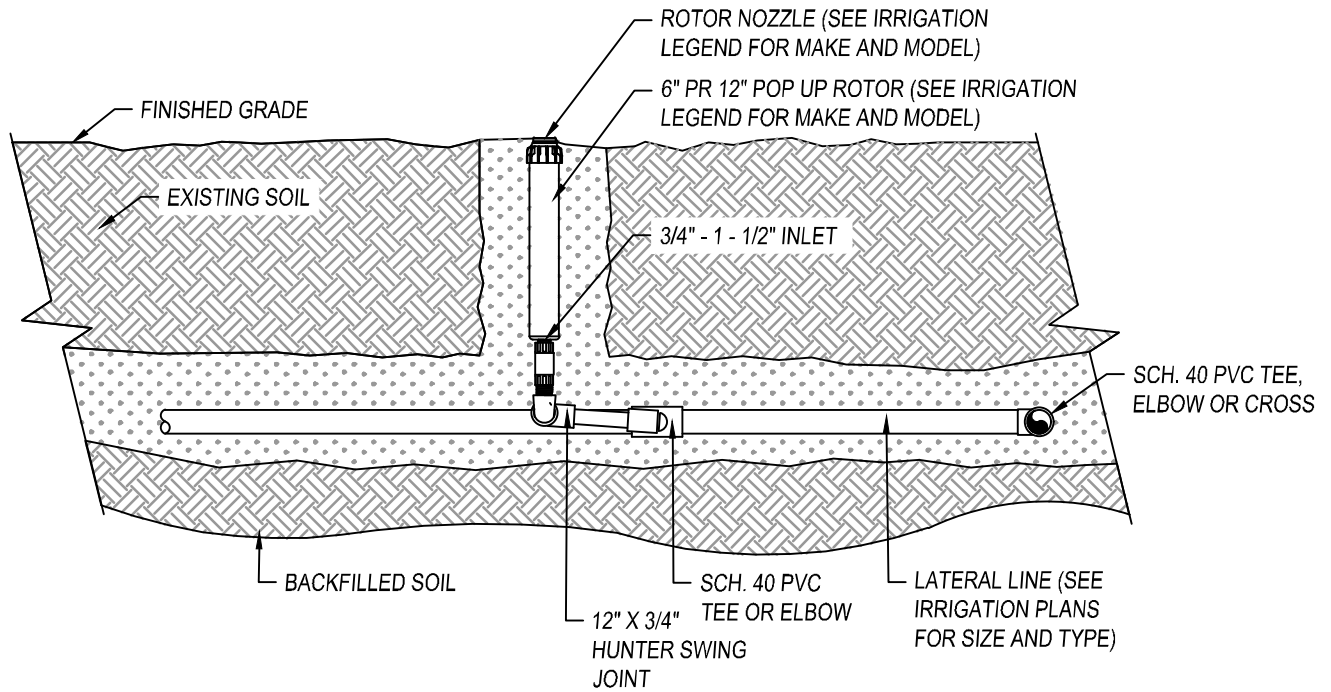

SECTION VIEW

NOTES:

1. ALL IRRIGATION FITTINGS UNLESS SPECIFIED OTHERWISE SHALL BE SCH. 40 PVC.
2. A SCH. 80 NIPPLE SHALL BE INSTALLED BETWEEN THE SWING JOINT AND CHECK VALVE SO THE TOP OF THE ROTOR IS FLUSH WITH FINISHED GRADE AS NEEDED.
3. PRIOR TO MULCHING THE CONTRACTOR SHALL SETTLE ALL OF THE SOIL IN THE IRRIGATION TRENCHES AND AROUND EACH EMITTER SO WATER FLOWS EVENLY THROUGH THE SOIL.
4. THE CONTRACTOR SHALL THOROUGHLY FLUSH THE LINES A MINIMUM OF THREE (3) TIMES PRIOR TO INSTALLING THE NOZZLE.



CITY COUNCIL APPROVAL: 01/24/2023

[Signature]
APPROVED BY CITY ENGINEER

[Signature]
APPROVED BY PUBLIC WORKS DIRECTOR

ROTOR SPRAY HEAD

PUBLIC IMPROVEMENT STANDARDS

L-15

REVISIONS		
NAME	BY	DATE

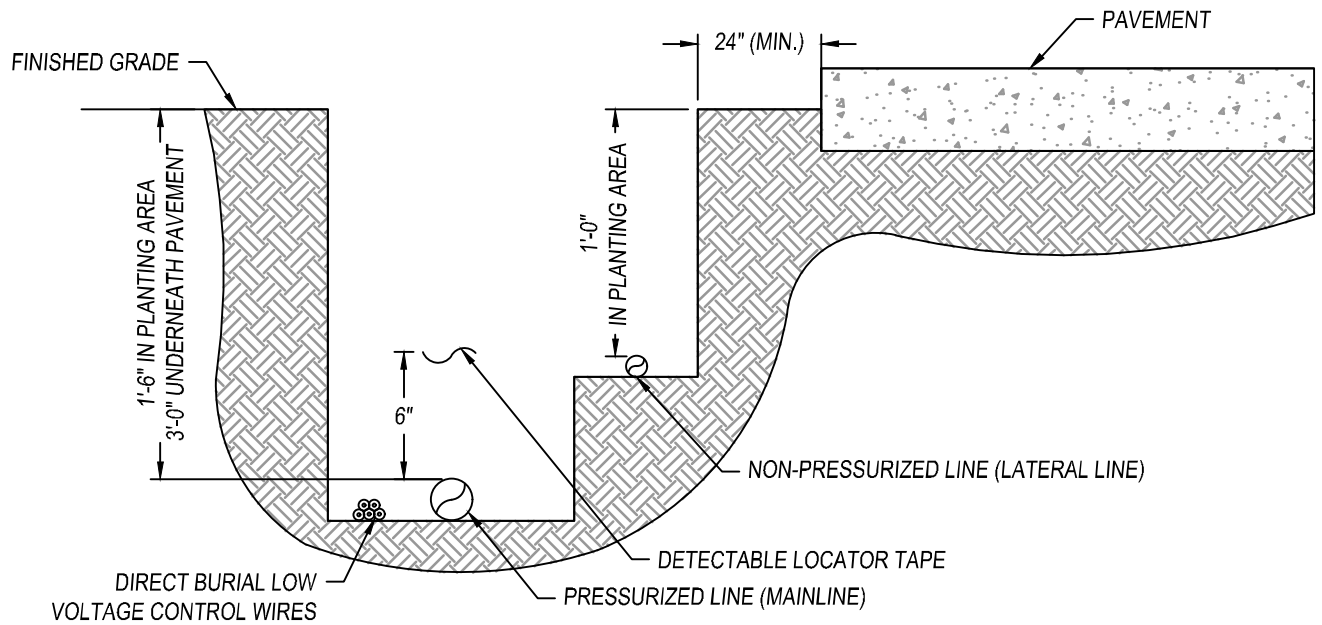

NOTES:

1. SEE IRRIGATION LEGEND FOR MAINLINE AND LATERAL LINE PIPE SIZE AND TYPE.
2. 2-WIRE IRRIGATION WIRE SHALL BE INSTALLED IN 1-1/2" SCH. 40 PVC ELECTRICAL CONDUIT.
3. DETECTABLE LOCATOR TAPE SHALL BE LOCATED SIX INCHES (6") ABOVE THE ENTIRE MAINLINE RUN.
4. IN PLANTING AREAS LESS THAN SIX FEET (6') WIDE THE MAINLINES AND LATERAL LINE HEADERS SHALL BE LOCATED NO FURTHER THAN 12" FROM THE ADJACENT PAVEMENT.



CITY COUNCIL APPROVAL: 01/24/2023

[Signature]
APPROVED BY CITY ENGINEER

[Signature]
APPROVED BY PUBLIC WORKS DIRECTOR

IRRIGATION TRENCHING

PUBLIC IMPROVEMENT STANDARDS

L-16

REVISIONS

NAME	BY	DATE

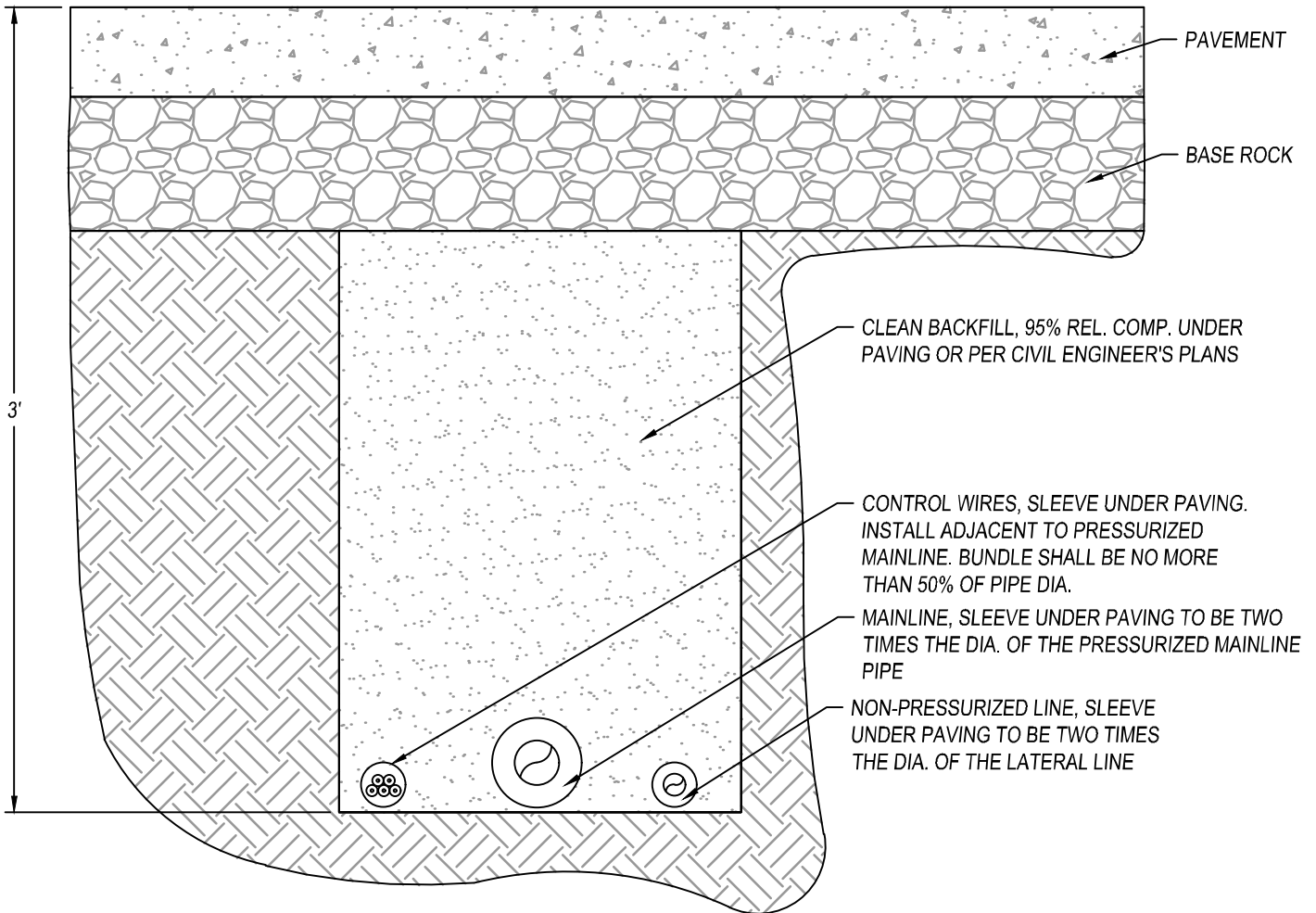

NOTES:

1. SEE IRRIGATION LEGEND FOR MAINLINE SIZE AND TYPE.
2. ALL SLEEVES SHALL BE SCH. 40 PVC PIPE.
3. ALL SLEEVES SHALL EXTEND 12" BEYOND THE EDGE OF PAVEMENT.
4. END OF SLEEVES SHALL BE LOCATED WITH A WOODEN STAKE OR PVC PIPE. LOCATORS SHALL RUN CONTINUOUSLY FROM THE END OF THE SLEEVE TO FINISHED GRADE.



CITY COUNCIL APPROVAL: 01/24/2023

[Signature]
APPROVED BY CITY ENGINEER

[Signature]
APPROVED BY PUBLIC WORKS DIRECTOR

PIPE AT PAVEMENT

PUBLIC IMPROVEMENT STANDARDS

L-17

REVISIONS

NAME	BY	DATE

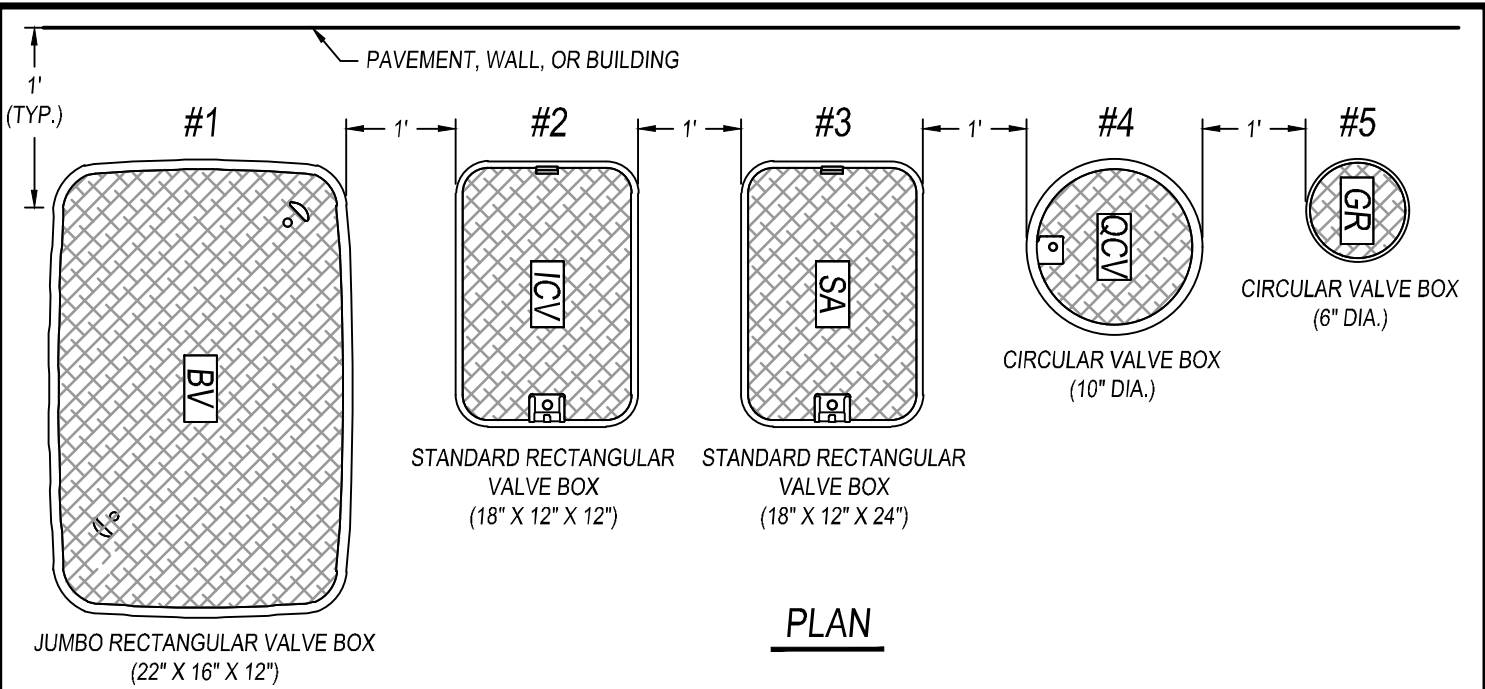

WATER TYPE	CONTROLLER	DESIGNATION	BOX SIZE	LID COLOR	I.D. GUIDE
PW	A	MV	#2	GREEN	MASTER VALVE
PW	A	FS	#2	GREEN	FLOW SENSOR
PW	A	HM	#2	GREEN	HYDROMETER
PW	A	BV	#2	GREEN	BALL VALVE 3" OR LESS
PW	A	BV	#1	GREEN	BALL VALVE 4" OR MORE
PW	A	GV	#2	GREEN	GATE VALVE
PW	A	ARV	#2	GREEN	AIR RELEASE VALVE
PW	A	QCV	#4	GREEN	QUICK COUPLER VALVE
PW	A	RCV	#2	GREEN	REMOTE CONTROL VALVE
PW	A	MS	#2	GREEN	MOISTURE SENSOR
PW	A	GR	#5	GREEN	GROUNDING ROD
PW	A	SB	#4	GREEN	SPLICE BOX
PW	A	FC	#2	GREEN	FUTURE CONNECTION
PW	A	SA	#3	GREEN	SURGE ARRESTOR

EXAMPLE:

POTABLE WATER SYSTEM ON CONTROLLER 'A',
REMOTE CONTROL VALVE STATION # 3.

NOTES:

1. VALVE BOX # 1 THRU # 4 SHALL HAVE STAINLESS STEEL LOCKING HARDWARE.
2. VALVE BOXES SHALL BE LABELED BY HOT IRON BRANDING OR ALUMINUM ASPHALTIC BASE WATER PROOF PAINT.
3. LOCATE VALVE ASSEMBLIES IN PLANTING AREA.
4. VALVE LOCATIONS SHALL BE APPROVED BY THE OWNER'S REPRESENTATIVE PRIOR TO INSTALLATION.
5. VALVE BOXES SHALL BE CENTERED ABOVE VALVE ASSEMBLIES TO FACILITATE ACCESS AND MAINTENANCE.
6. VALVE BOXES SHALL BE FLUSH WITH FINISHED GRADE.
7. VALVE BOXES SHALL BE SET PARALLEL TO EACH OTHER AND PERPENDICULAR TO THE EDGE OF PAVEMENT.
8. SEE OTHER IRRIGATION DETAILS FOR FURTHER INFORMATION.



CITY COUNCIL APPROVAL: 01/24/2023

APPROVED BY CITY ENGINEER

APPROVED BY PUBLIC WORKS DIRECTOR

VALVE BOX LAYOUT

PUBLIC IMPROVEMENT STANDARDS

L-18

REVISIONS		
NAME	BY	DATE

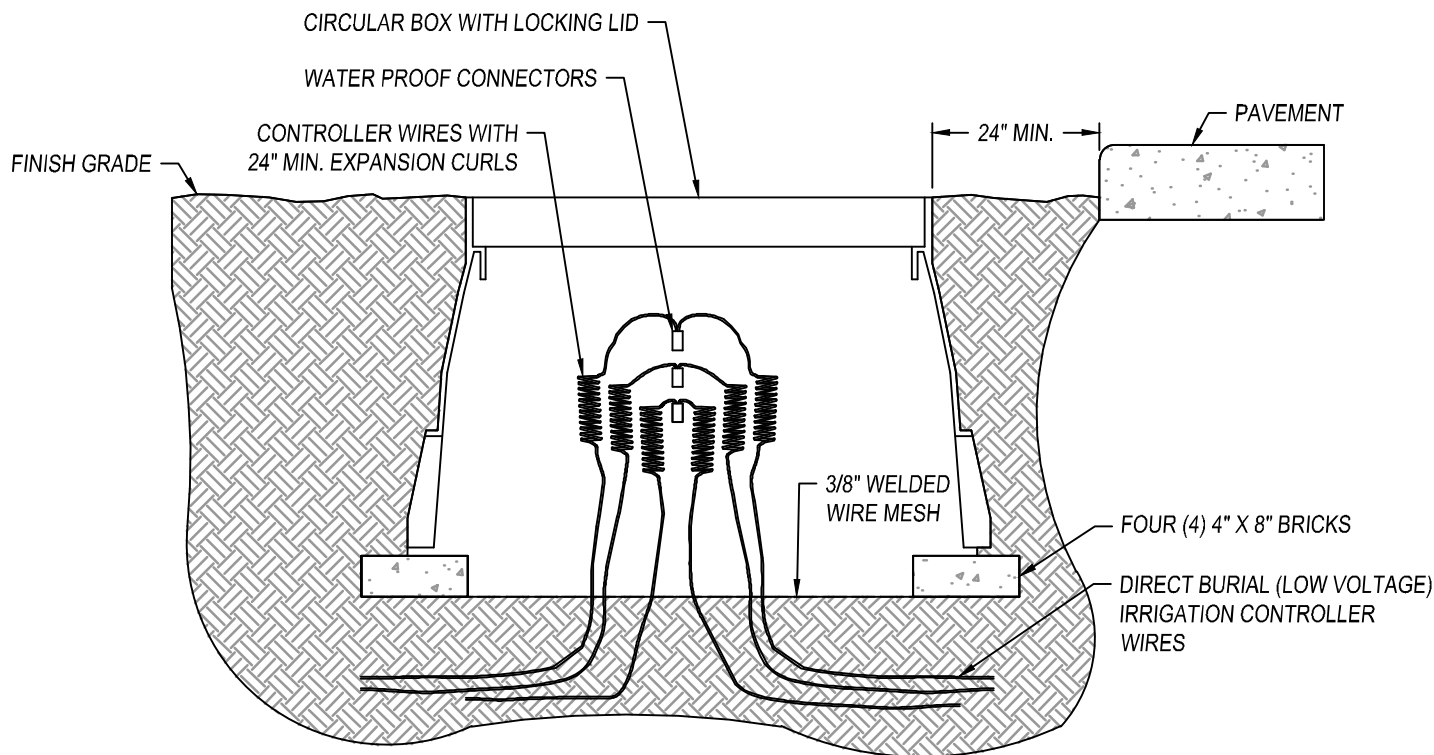

NOTES:

1. VALVE BOXES SHALL BE LOCATED IN PLANTING AREAS.
2. SPLICES SHALL ONLY BE MADE AT ELECTRICAL PULL BOXES.
3. LOW VOLTAGE WIRES UNDER ROADWAYS MUST BE IN CONTINUOUS CONDUIT WITH 90° SCH. 40 PVC SWEEPS TERMINATING IN PULL BOXES.
4. ALL WIRE CONNECTIONS SHALL BE MADE USING DBR/Y-6 CONNECTORS OR APPROVED EQUAL.
5. VALVE BOX SHALL BE WRAPPED WITH MINIMUM 3 MIL. THICK PLASTIC AND SECURE IT USING DUCT TAPE OR ELECTRICAL TAPE.



CITY COUNCIL APPROVAL: 01/24/2023

[Signature]
APPROVED BY CITY ENGINEER

[Signature]
APPROVED BY PUBLIC WORKS DIRECTOR

SPLICE BOX

PUBLIC IMPROVEMENT STANDARDS

L-19

REVISIONS

NAME	BY	DATE

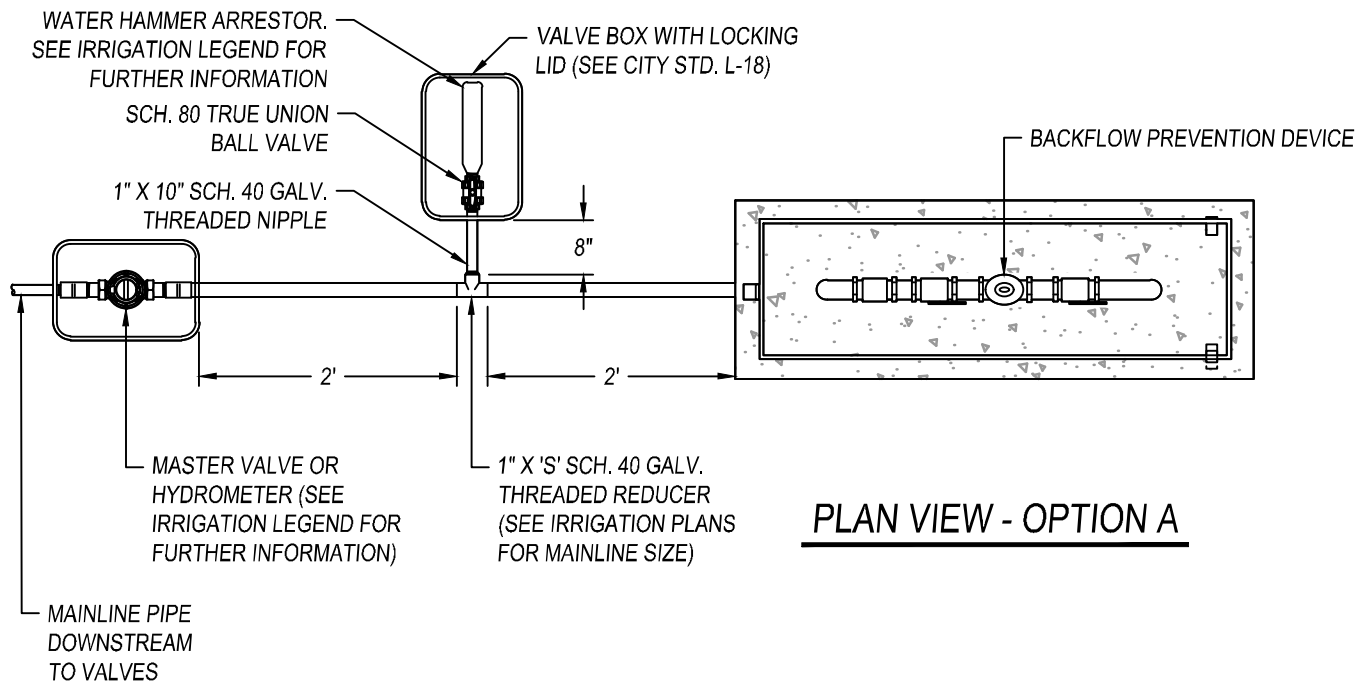

PLAN VIEW - OPTION A

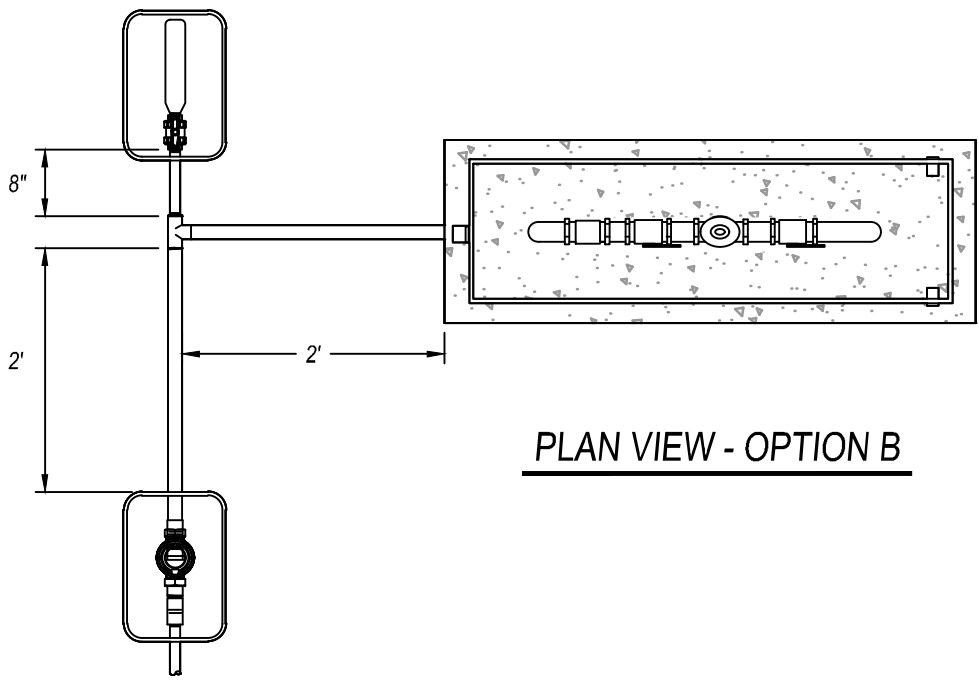

PLAN VIEW - OPTION B

NOTES:

1. LOCATE VALVE BOXES IN PLANTING AREAS.
2. WRAP VALVE BOXES WITH A MINIMUM OF 3 MIL PLASTIC AND SECURE IT USING DUCT TAPE OR ELECTRICAL TAPE.
3. PLACE ONE (1) BRICK AT EACH CORNER OF THE VALVE BOX FOR STABILIZATION.
4. ALL THREADED CONNECTIONS ARE TO BE MADE WITH PIPE DOPE OR TEFLON TAPE.
5. 3" OF WASHED PEA GRAVEL SHALL BE PLACED AT THE BOTTOM OF THE VALVE BOX.



CITY COUNCIL APPROVAL: 01/24/2023

[Signature]
APPROVED BY CITY ENGINEER

[Signature]
APPROVED BY PUBLIC WORKS DIRECTOR

WATER HAMMER ARRESTOR

PUBLIC IMPROVEMENT STANDARDS

L-20		
REVISIONS		
NAME	BY	DATE

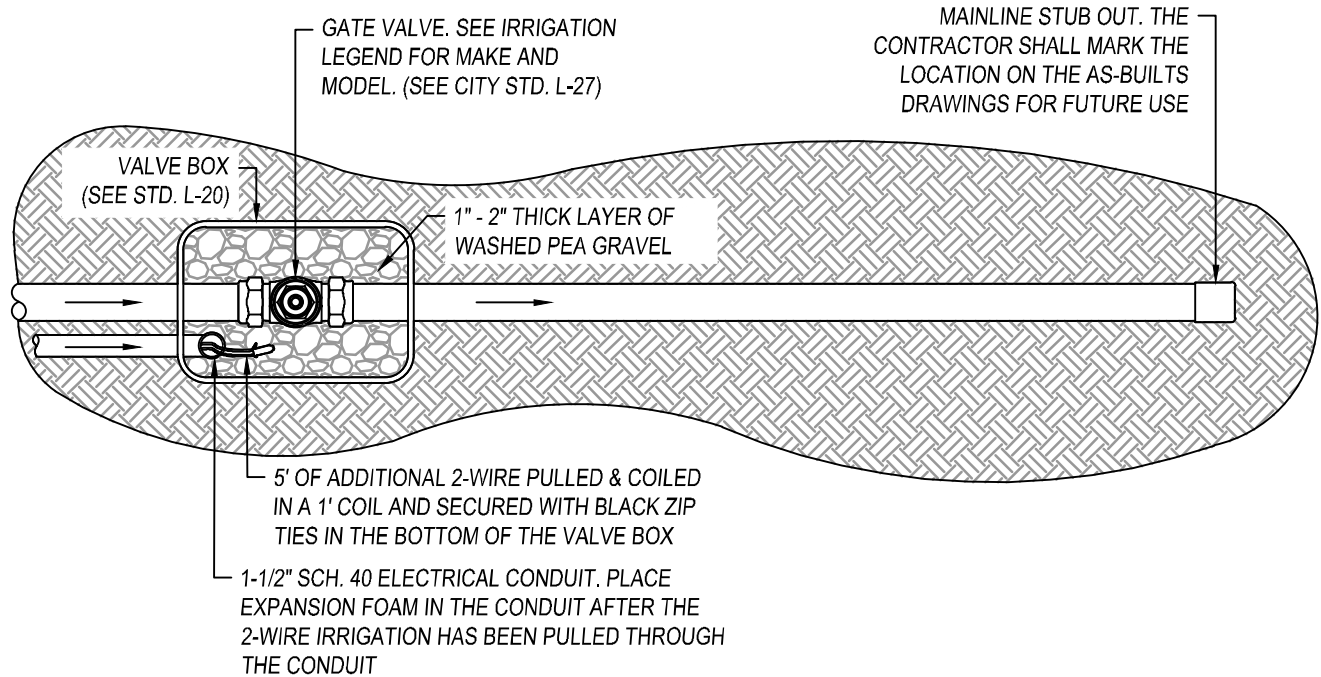
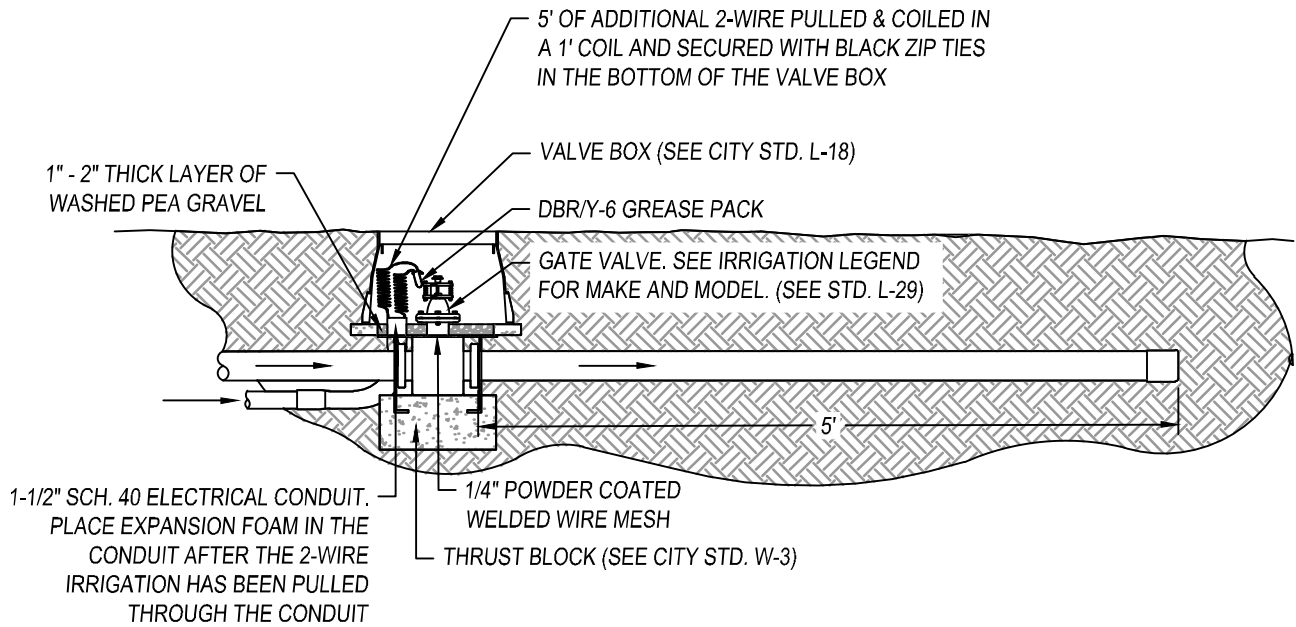

NOTES:

1. THE CONTRACTOR SHALL LOCATE THE MAINLINE SHUT OFF VALVE IN A RECTANGULAR LOCKING VALVE BOX.
2. PRIOR TO INSTALLING THE CAP ON THE MAINLINE THE CONTRACTOR SHALL BLOW OUT THE MAINLINE OF ANY AND ALL DEBRIS INSIDE THE MAINLINE THAT MAY HAVE COLLECTED DURING CONSTRUCTION.
3. THE CONTRACTOR SHALL MARK THE CAP OF THE PIPE WITH A 12" #4 REBAR PLACED 4" - 6" BELOW FINISH GRADE FOR EASE OF LOCATING.



CITY COUNCIL APPROVAL: 01/24/2023

[Signature]
APPROVED BY CITY ENGINEER

[Signature]
APPROVED BY PUBLIC WORKS DIRECTOR

MAINLINE STUB OUT

PUBLIC IMPROVEMENT STANDARDS

L-21

REVISIONS

NAME	BY	DATE

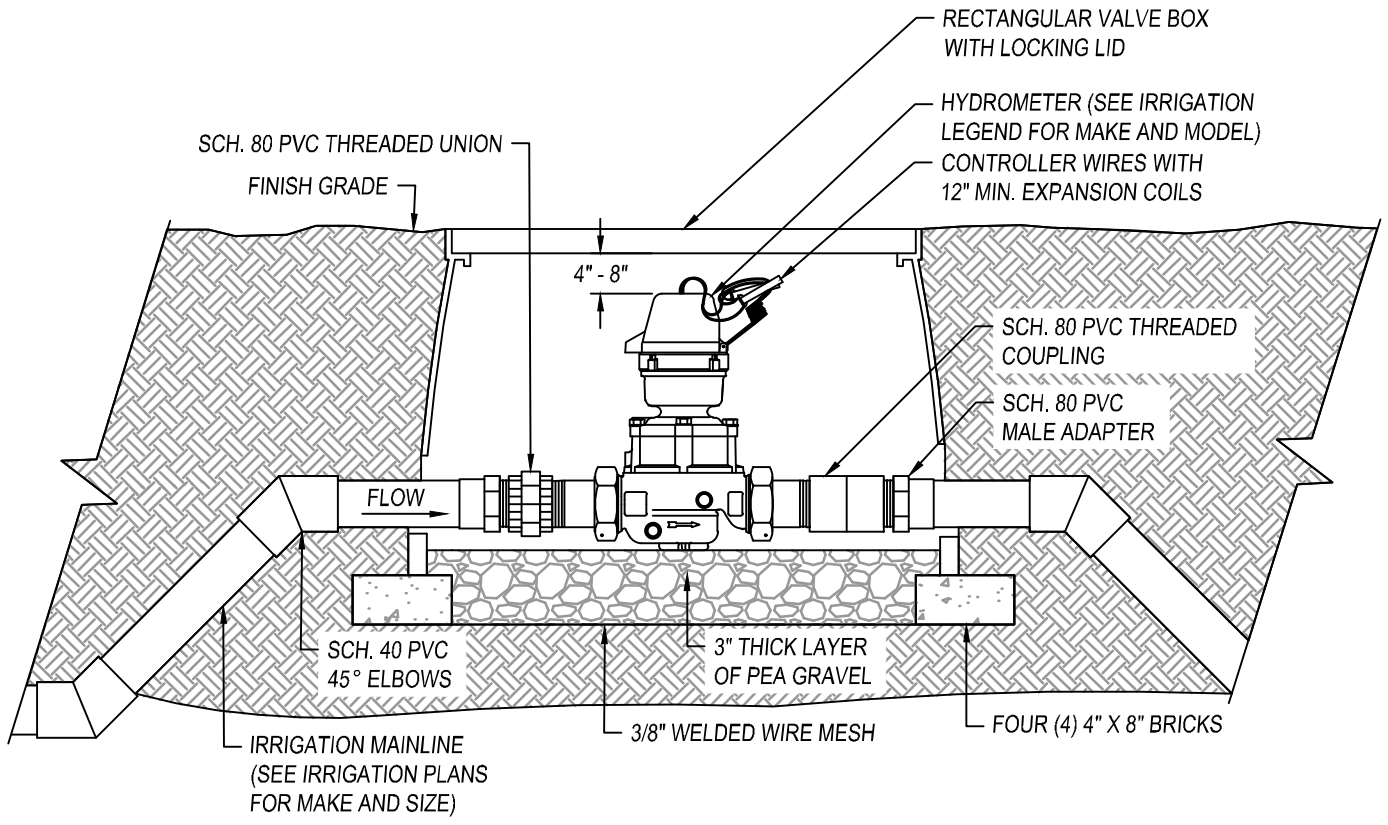

NOTES:

1. HYDROMETER SHALL BE REED SWITCH (RS) REGISTER OR PHOTO DIODE HIGH FREQUENCY (PDH) REGISTER.
2. CHECK WITH CONTROLLER MANUFACTURER AND INSTALL PER THEIR SPECIFICATIONS AND RECOMMENDATIONS.
3. HYDROMETER SHALL BE INSTALLED PER MANUFACTURE'S SPECIFICATIONS AND RECOMMENDATIONS.
4. HYDROMETER WIRE SHALL BE PER THE IRRIGATION CONTROLLER MANUFACTURER'S SPECIFICATIONS.
5. ALL WIRE RUNS SHALL BE CONTINUOUS WITHOUT ANY SPLICES. WIRE CONNECTIONS SHALL BE MADE USING DBR-Y/6 OR APPROVED EQUAL.
6. VALVE BOX SHALL BE WRAPPED WITH A MINIMUM 3 MIL. THICK PLASTIC AND SECURE IT TO THE VALVE BOX USING DUCT TAPE OR ELECTRICAL TAPE.
7. VALVE BOX SHALL BE LOCATED IN PLANTING AREA.



CITY COUNCIL APPROVAL: 01/24/2023

[Signature]
APPROVED BY CITY ENGINEER

[Signature]
APPROVED BY PUBLIC WORKS DIRECTOR

HYDROMETER

PUBLIC IMPROVEMENT STANDARDS

L-22		
REVISIONS		
NAME	BY	DATE

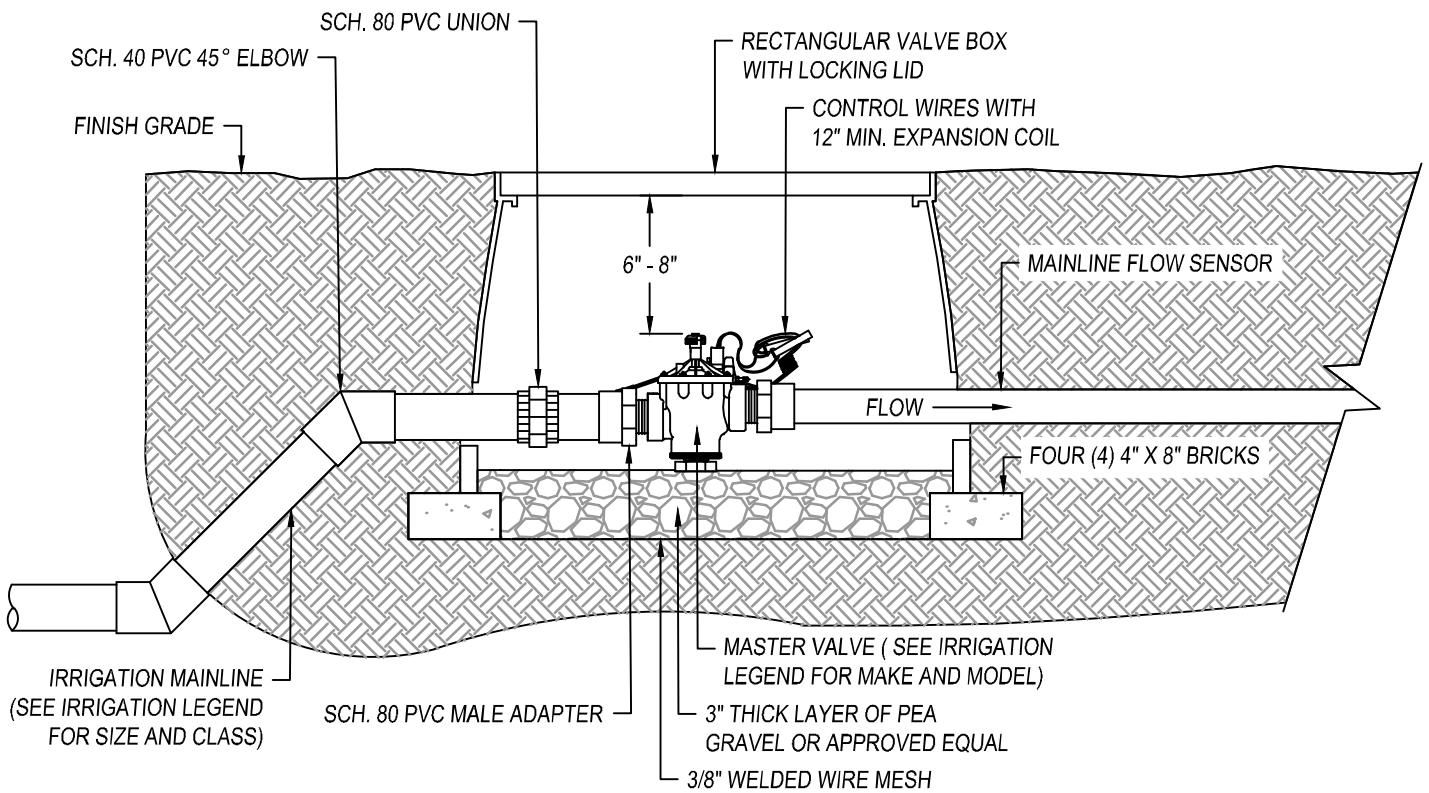

NOTES:

1. MASTER VALVE SHALL BE MAKE AND MODEL NUMBER AS PRESCRIBED PER THE CONTROLLER MANUFACTURER'S SPECIFICATIONS.
2. INSTALL MASTER VALVE PER MANUFACTURER'S SPECIFICATIONS AND RECOMMENDATIONS.
3. MASTER VALVE WIRE SHALL BE 14 AWG OR LARGER. COLOR: BLACK.
4. ALL WIRE RUNS SHALL BE CONTINUOUS WITHOUT ANY SPLICES. WIRE CONNECTIONS SHALL BE MADE USING DBR-Y/6 CONNECTORS OR APPROVED EQUAL.
5. WRAP VALVE BOX WITH MIN. 3 MIL. THICK PLASTIC AND SECURE IT TO THE VALVE BOX USING DUCT TAPE OR ELECTRICAL TAPE.
6. SEE MASTER VALVE/ FLOW SENSOR DETAIL FOR LINEAR DIMENSIONS.
7. VALVE BOXES SHALL BE LOCATED IN PLANTING AREAS.



CITY COUNCIL APPROVAL: 01/24/2023

[Signature]
APPROVED BY CITY ENGINEER

[Signature]
APPROVED BY PUBLIC WORKS DIRECTOR

MASTER VALVE

PUBLIC IMPROVEMENT STANDARDS

L-23		
REVISIONS		
NAME	BY	DATE

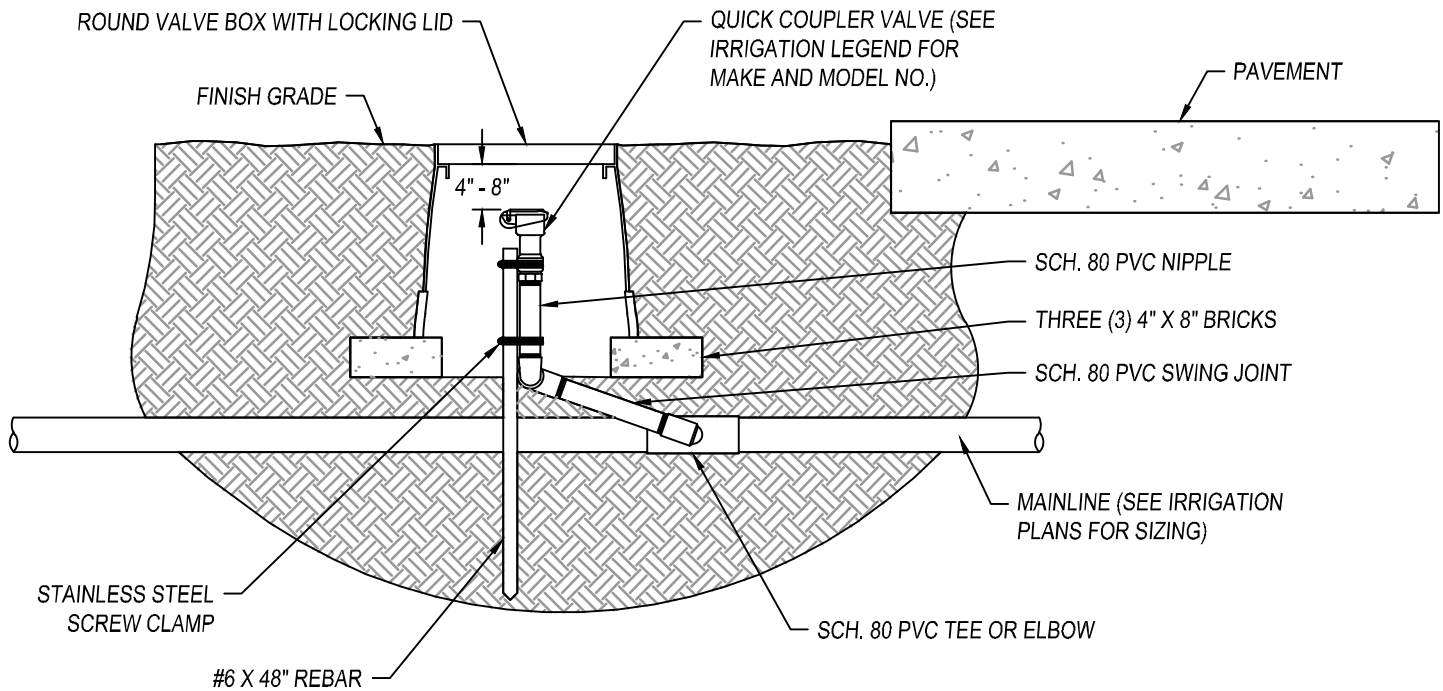

NOTES:

1. ALL THREADED CONNECTIONS SHALL BE INSTALLED USING TEFLON TAPE.
2. VALVE BOX SHALL BE WRAPPED WITH A MINIMUM 3 MIL THICK PLASTIC AND SECURED TO THE VALVE BOX USING DUCT TAPE OR ELECTRICAL TAPE.
3. ALL QUICK COUPLERS SHALL BE INSTALLED A MINIMUM OF 18" OFF OF THE MAINLINE.
4. VALVE BOXES SHALL BE LOCATED IN PLANTING AREAS.



CITY COUNCIL APPROVAL: 01/24/2023

[Signature]
APPROVED BY CITY ENGINEER

[Signature]
APPROVED BY PUBLIC WORKS DIRECTOR

QUICK COUPLER VALVE

PUBLIC IMPROVEMENT STANDARDS

L-24

REVISIONS

NAME	BY	DATE

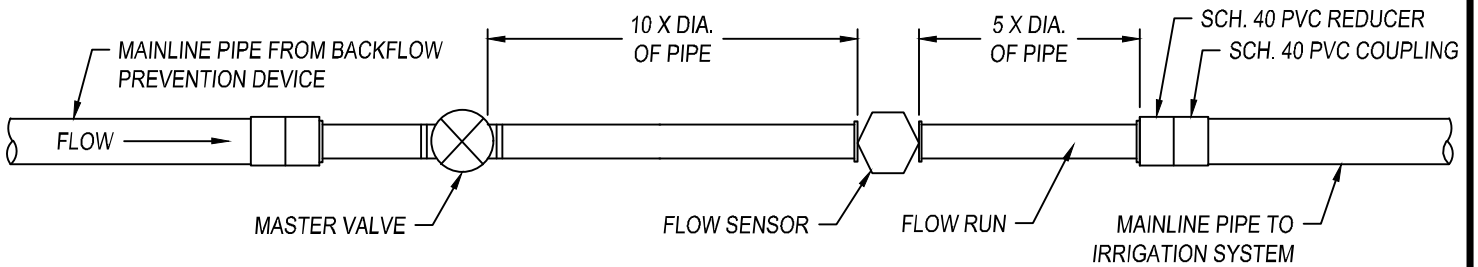

NOTES:

1. FLOW SENSOR SHALL BE OF MAKE AND MODEL AS RECOMMENDED BY THE CONTROLLER MANUFACTURER.
2. FLOW SENSOR WIRE SHALL BE PER MANUFACTURER'S SPECIFICATIONS.
3. MASTER VALVE WIRE SHALL BE DIRECT BURIAL 14 AWG WIRE (OR LARGER). COLOR: BLACK.
4. ALL WIRE RUNS SHALL BE CONTINUOUS WITHOUT ANY SPLICES.
5. SEE MASTER VALVE DETAIL AND FLOW SENSOR DETAIL FOR FURTHER INFORMATION.
6. FLOW RUN PIPE SHALL BE REDUCED DOWN ONE (1) PIPE SIZE AS INDICATED.

EXAMPLE

- 3" MAINLINE = 2-1/2" FLOW RUN
- 2-1/2" MAINLINE = 2" FLOW RUN
- 2" MAINLINE = 1-1/2" FLOW RUN



CITY COUNCIL APPROVAL: 01/24/2023

[Signature]
APPROVED BY CITY ENGINEER

[Signature]
APPROVED BY PUBLIC WORKS DIRECTOR

MASTER VALVE & FLOW SENSOR LAYOUT

PUBLIC IMPROVEMENT STANDARDS

L-25		
REVISIONS		
NAME	BY	DATE

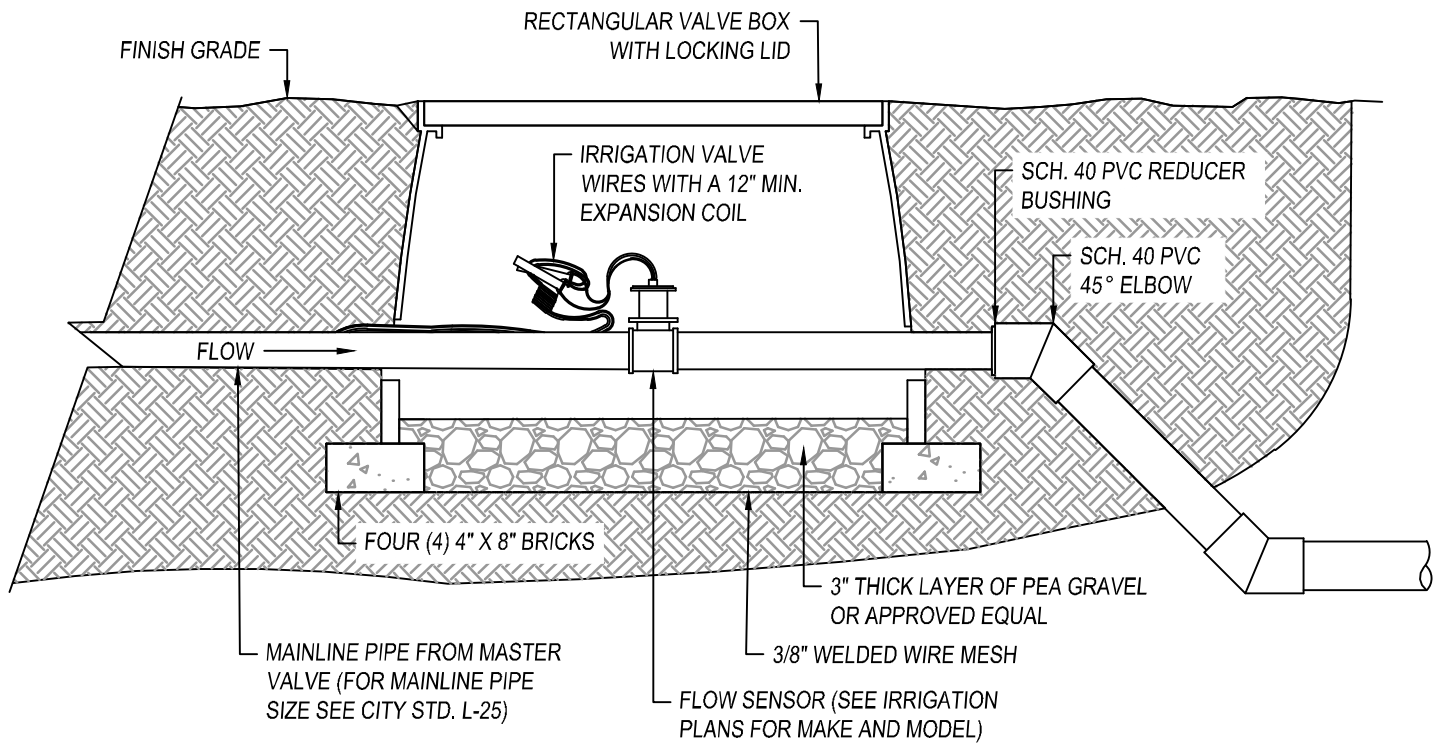

NOTES:

1. FLOW SENSOR MAKE AND MODEL NUMBER SHALL BE PER CONTROLLER MANUFACTURER'S SPECIFICATIONS AND RECOMMENDATIONS (SEE IRRIGATION PLANS).
2. FLOW SENSOR WIRE SHALL BE PER THE CONTROLLER MANUFACTURER'S SPECIFICATIONS.
3. INSTALL FLOW SENSOR PER MANUFACTURER'S SPECIFICATIONS AND RECOMMENDATIONS.
4. ALL WIRE RUNS SHALL BE CONTINUOUS WITHOUT ANY SPLICES. WIRE CONNECTIONS SHALL BE MADE USING DBR/Y-6 CONNECTORS OR APPROVED EQUAL.
5. VALVE BOX SHALL BE WRAPPED WITH A MIN. OF THREE (3) MIL THICK PLASTIC AND SECURE IT TO THE VALVE BOX USING DUCT TAPE OR ELECTRICAL TAPE.
6. SEE CITY STD. L-27 FOR LINEAR DIMENSIONS.



CITY COUNCIL APPROVAL: 01/24/2023

[Signature]
APPROVED BY CITY ENGINEER

[Signature]
APPROVED BY PUBLIC WORKS DIRECTOR

FLOW SENSOR

PUBLIC IMPROVEMENT STANDARDS

L-26		
REVISIONS		
NAME	BY	DATE

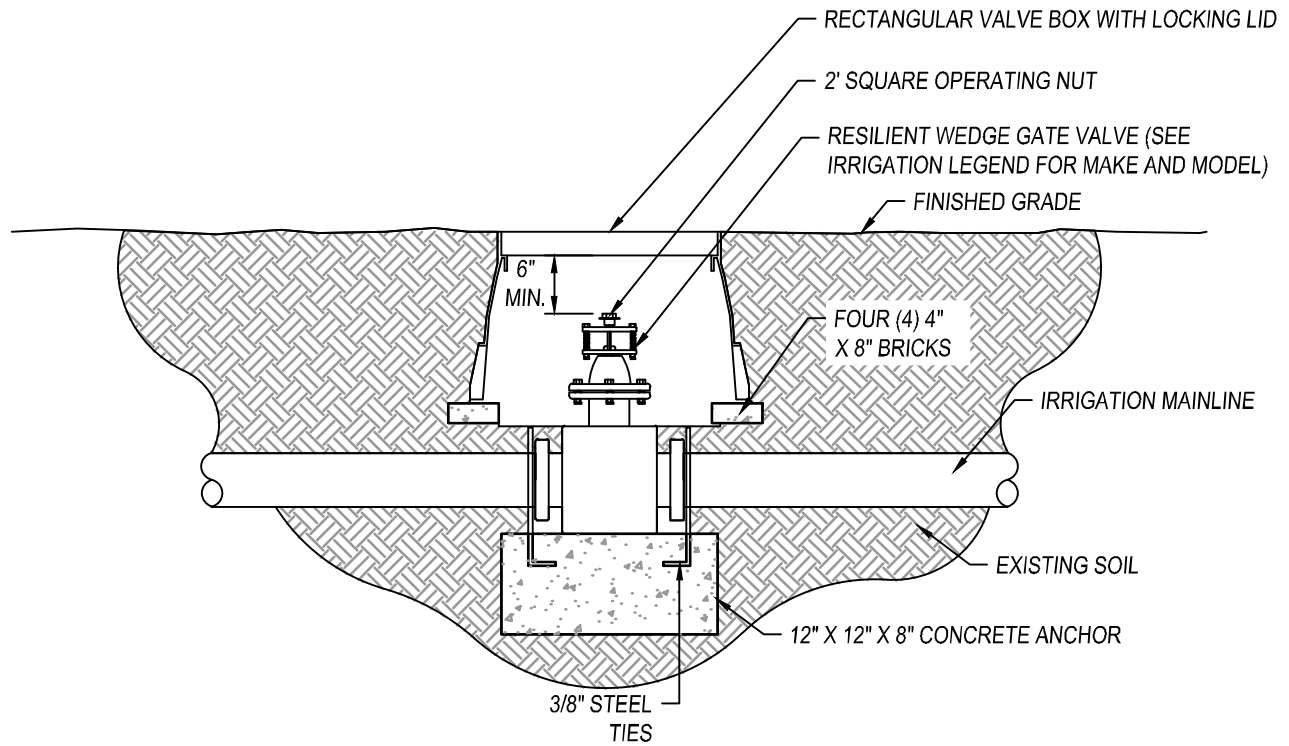

NOTES:

1. INSTALL GATE VALVE PER MANUFACTURER'S SPECIFICATIONS AND RECOMMENDATIONS.
2. VALVE BOX SHALL BE WRAPPED WITH MINIMUM 3 MIL. THICK PLASTIC AND SECURE IT TO VALVE BOX USING DUCT TAPE OR ELECTRICAL TAPE.
3. VALVE BOX SHALL BE LOCATED IN PLANTING AREA.



CITY COUNCIL APPROVAL: 01/24/2023

[Signature]
APPROVED BY CITY ENGINEER

[Signature]
APPROVED BY PUBLIC WORKS DIRECTOR

GATE VALVE AND ANCHOR

PUBLIC IMPROVEMENT STANDARDS

L-27

REVISIONS

NAME	BY	DATE

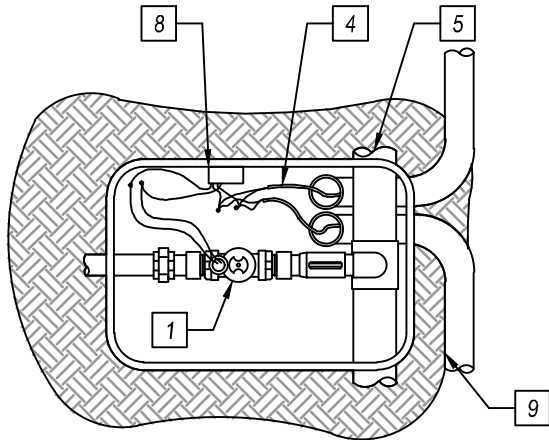

PLAN VIEW

- 1 SEE DETAIL FOR IRRIGATION VALVE. SEE IRRIGATION PLANS FOR PIPING.
- 2 WATERPROOF CONNECTIONS TO VALVE. 3M DBR-Y/6 GREASE PACKS OR APPROVED EQUAL.
- 3 WATERPROOF CONNECTIONS FOR COMMON WIRE TO VALVE. 3M DBR-Y/6 GREASE PACKS OR APPROVED EQUAL.
- 4 TWO-WIRE IRRIGATION WIRE. (SEE SPECIFICATIONS FOR FURTHER INFORMATION).
- 5 IRRIGATION MAINLINE, SEE IRRIGATION PLANS FOR FURTHER INFORMATION.
- 6 TWO-WIRE RED WIRE TO RED BICODER WIRE WITH A WATERPROOF CONNECTOR 3M DBR-Y/6 GREASE PACKS OR APPROVED EQUAL.
- 7 BLACK TWO-WIRE IRRIGATION WIRE TO WATERPROOF CONNECTOR 3M DBR-Y/6 GREASE PACKS OR APPROVED EQUAL.
- 8 TWO-WIRE IRRIGATION DECODER. SEE IRRIGATION PLANS FOR MAKE AND MODEL. ATTACH TO THE VALVE BOX USING A STAINLESS STEEL SELF TAPPING SCREW.
- 9 1-1/2" SCH. 40 ELECTRICAL CONDUIT.

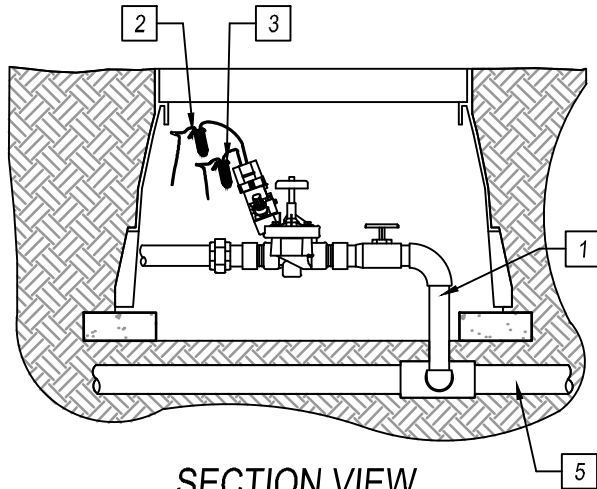

SECTION VIEW

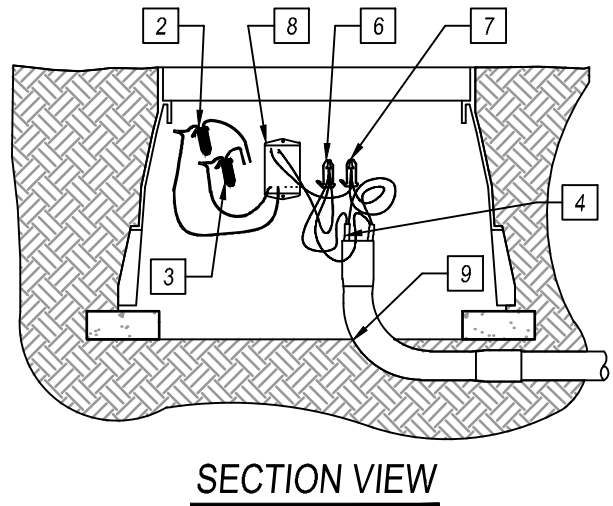

SECTION VIEW

NOTES:

- 1. CONTRACTOR SHALL PROVIDE FIVE (5) ADDITIONAL FEET OF 2-WIRE AT EACH VALVE LOCATION AND COIL IT UNDERNEATH THE IRRIGATION VALVE AND SECURE IT WITH BLACK ZIP TIES.



CITY COUNCIL APPROVAL: 01/24/2023
 APPROVED BY CITY ENGINEER
 APPROVED BY PUBLIC WORKS DIRECTOR

2-WIRE IRRIGATION CONNECTIONS
PUBLIC IMPROVEMENT STANDARDS

L-28		
REVISIONS		
NAME	BY	DATE

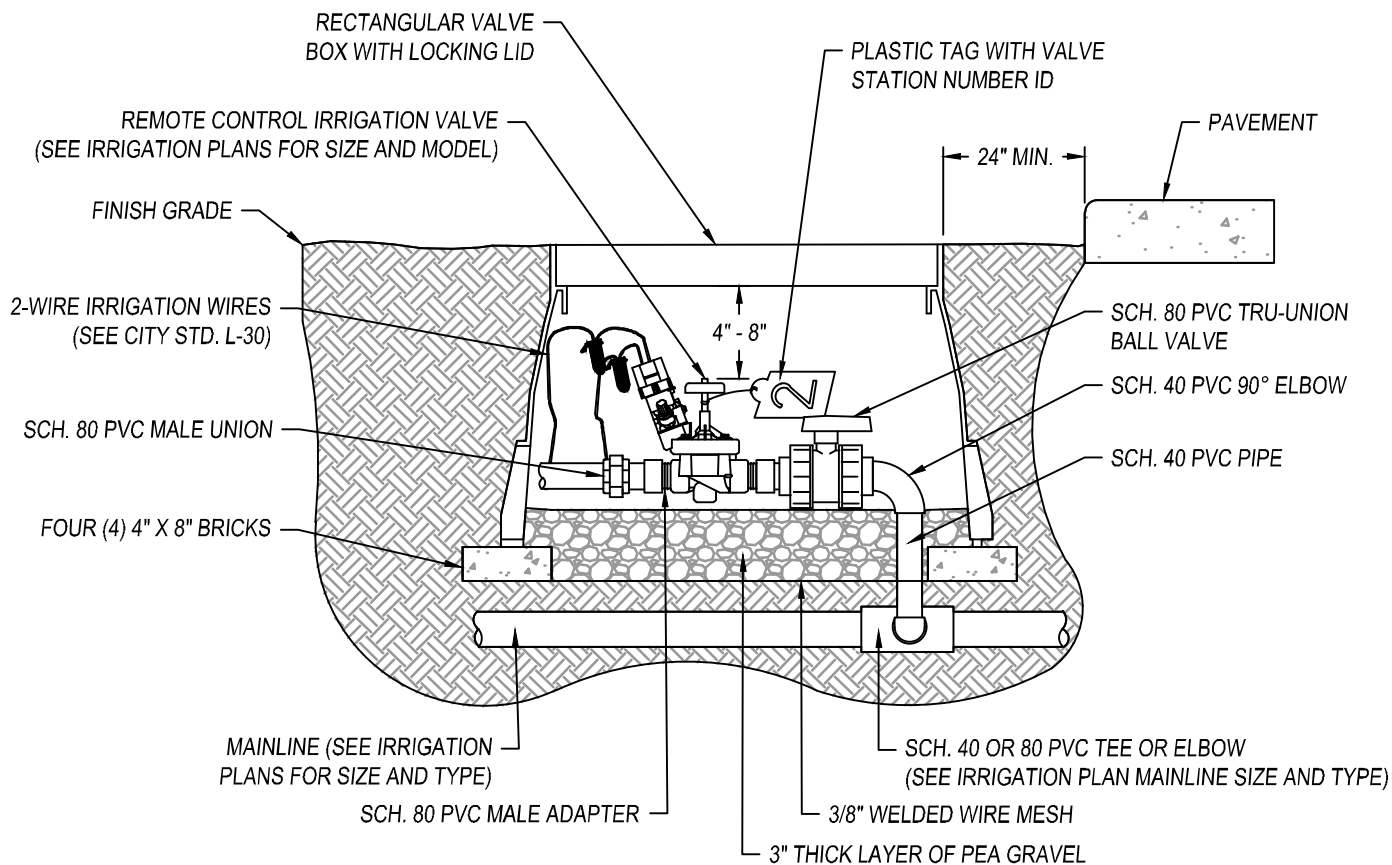

NOTES:

1. COMMON WIRE AND CONTROLLER WIRE SHALL BE DIRECT BURIAL 14 AWG OR LARGER CONTROLLER MANUFACTURER APPROVED 2-WIRE IRRIGATION WIRE .
2. ALL WIRE RUNS SHALL BE CONTINUOUS WITHOUT ANY SPLICES UNLESS APPROVED BY THE OWNER'S REPRESENTATIVE. SEE SPLICE BOX DETAIL. WIRE CONNECTIONS SHALL BE MADE USING DBR/Y-6 CONNECTORS OR APPROVED EQUAL.
3. CONTRACTOR SHALL COIL AND ADDITIONAL FIVE FEET (5') OF 2-WIRE IRRIGATION WIRE AT EACH VALVE FOR FUTURE USE AND SECURE IT BELOW THE VALVE USING BLACK ZIP TIES.
4. VALVE BOX SHALL BE WRAPPED WITH MIN. 3 MIL THICK PLASTIC AND SECURED USING DUCT TAPE OR ELECTRICAL TAPE.
5. MAINLINES 4" OR LARGER SHALL USE SADDLES AT THE CONNECTION POINTS TO THE IRRIGATION VALVE. (SEE SPECIFICATIONS FOR IRRIGATIONS SADDLES).
6. ALL SCH. 80 PVC TO SCH. 40 PVC THREADED CONNECTIONS SHALL BE MADE USING TEFLON TAPE.
7. VALVE BOXES SHALL BE LOCATED IN PLANTING AREAS.



CITY COUNCIL APPROVAL: 01/24/2023
 APPROVED BY CITY ENGINEER
 APPROVED BY PUBLIC WORKS DIRECTOR

2-WIRE REMOTE CONTROL VALVE

PUBLIC IMPROVEMENT STANDARDS

L-29

REVISIONS

NAME	BY	DATE

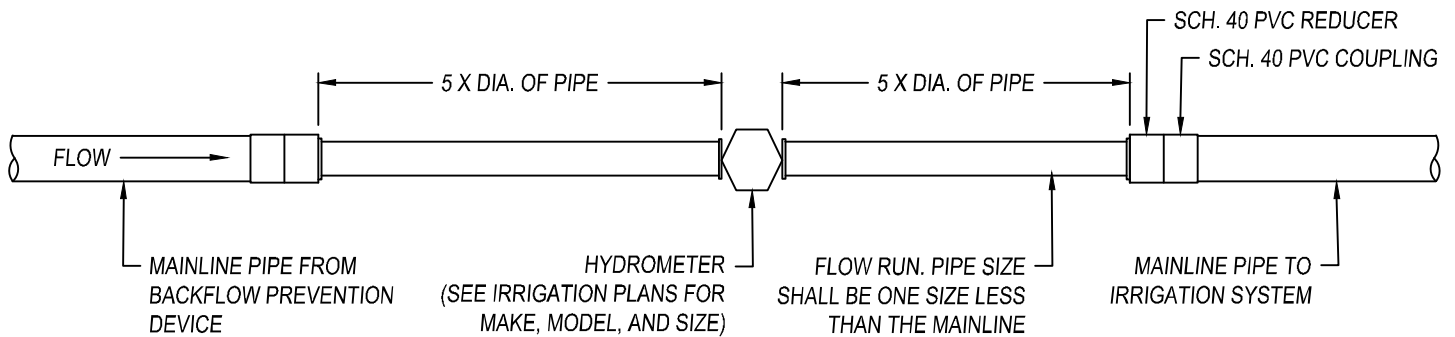

NOTES:

1. HYDROMETER SHALL BE OF MAKE AND MODEL AS RECOMMENDED BY THE CONTROLLER MANUFACTURER.
2. HYDROMETER WIRE SHALL BE PER MANUFACTURER'S SPECIFICATIONS.
3. ALL WIRE RUNS SHALL BE CONTINUOUS WITHOUT ANY SPLICES.
4. ALL WIRE SHALL BE PLACED IN 1-1/2" SCH. 40 ELECTRICAL CONDUIT.
5. SEE CITY STD. L-24 FOR FURTHER INFORMATION.
6. FLOW RUN PIPE SHALL BE REDUCED DOWN ONE (1) PIPE SIZE AS INDICATED.

EXAMPLE

- 3" MAINLINE = 2-1/2" FLOW RUN
- 2-1/2" MAINLINE = 2" FLOW RUN
- 2" MAINLINE = 1-1/2" FLOW RUN



CITY COUNCIL APPROVAL: 01/24/2023

[Signature]
APPROVED BY CITY ENGINEER

[Signature]
APPROVED BY PUBLIC WORKS DIRECTOR

HYDROMETER LAYOUT

PUBLIC IMPROVEMENT STANDARDS

L-30

REVISIONS

NAME	BY	DATE

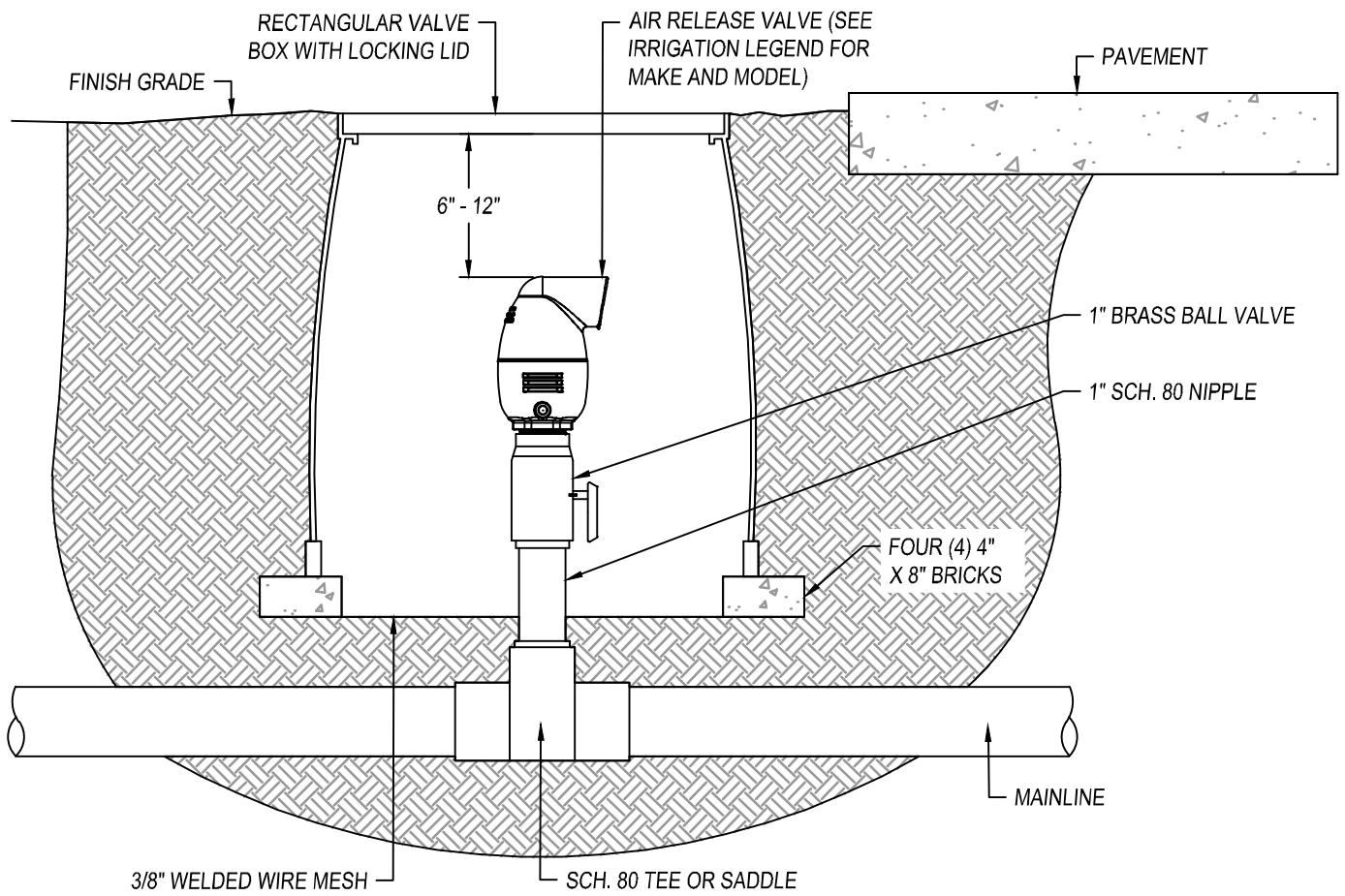

NOTES:

1. LOCATE VALVE BOXES IN PLANTING AREAS.
2. WRAP VALVE BOX WITH A MINIMUM OF 3 MIL THICK PLASTIC AND SECURE IT USING DUCT TAPE OR ELECTRICAL TAPE.
3. ALL THREADED CONNECTION TO BE MADE USING TEFLON TAPE OR PIPE DOPE.



CITY COUNCIL APPROVAL: 01/24/2023

[Signature]
APPROVED BY CITY ENGINEER

[Signature]
APPROVED BY PUBLIC WORKS DIRECTOR

1" AIR RELEASE VALVE

PUBLIC IMPROVEMENT STANDARDS

L-31

REVISIONS

NAME	BY	DATE

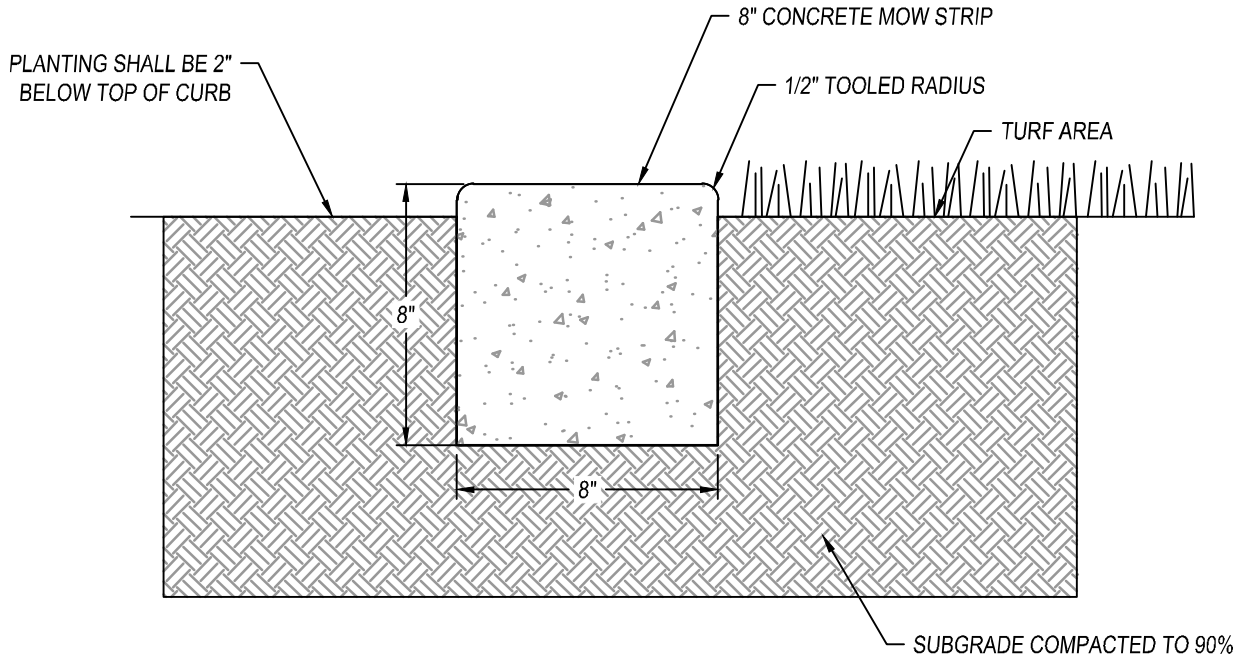

NOTES:

1. PROVIDE SCORE JOINTS AT 10'-0" O.C.
2. CONCRETE SHALL BE CLASS B, 5 SACK MIX.
3. EXPANSION JOINTS SHALL BE PROVIDED AT CORNERS OR WALLS AND EVERY 30'-0" O.C. MAXIMUM.



CITY COUNCIL APPROVAL: 01/24/2023

[Signature]
APPROVED BY CITY ENGINEER

[Signature]
APPROVED BY PUBLIC WORKS DIRECTOR

8" CONCRETE MOW STRIP

PUBLIC IMPROVEMENT STANDARDS

L-32

REVISIONS		
NAME	BY	DATE

BEFORE SHAVING

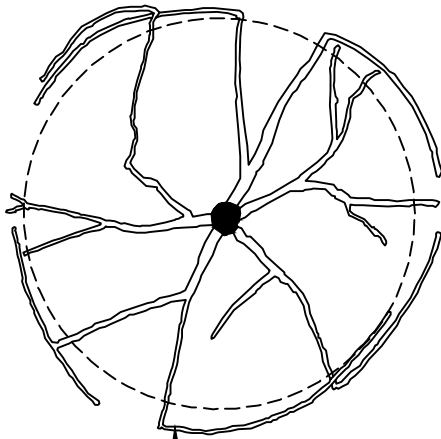

SHAVE ROOT BALL HERE
TO REMOVE ALL ROOTS
GROWING ON PERIPHERY

SHAVING PROCESS

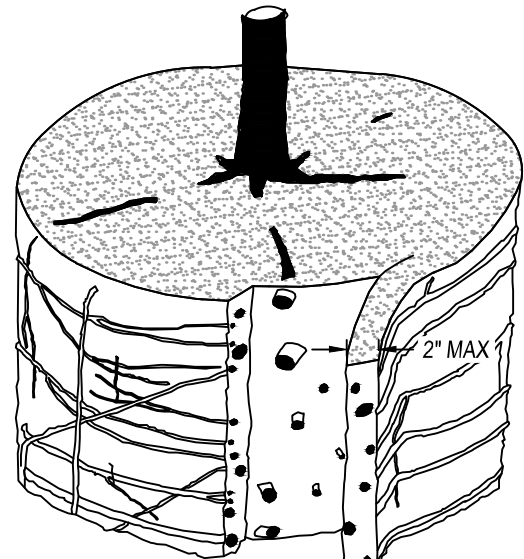

SHAVE OUTER
PERIPHERY OF
THE ROOT BALL A
MAX. OF 2" THICK

SHAVING COMPLETE

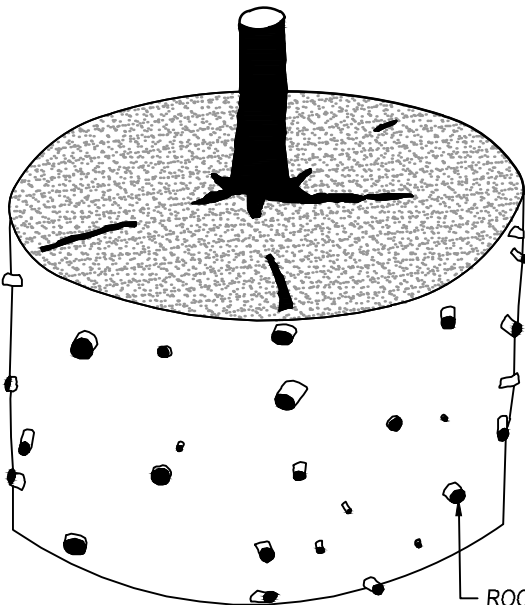

ROOTS TIPS EXPOSED AT PERIPHERY
OF ROOT BALL. ALL RODS GROWING
AROUND PERIPHERY ARE REMOVED

NOTES:

1. SHAVING TO BE CONDUCTED USING A SHARP BLADE OR HAND SAW ELIMINATING NO MORE THAN NEEDED TO REMOVE ALL ROOTS ON THE PERIPHERY OF ROOT BALL.
2. SHAVING CAN BE PERFORMED JUST PRIOR TO PLANTING OR AFTER PLACING IN THE HOLE.



CITY COUNCIL APPROVAL: 01/24/2023

 APPROVED BY CITY ENGINEER

 APPROVED BY PUBLIC WORKS DIRECTOR

ROOT BALL SHAVING

PUBLIC IMPROVEMENT STANDARDS

L-33

REVISIONS

NAME	BY	DATE

ACCEPTABLE

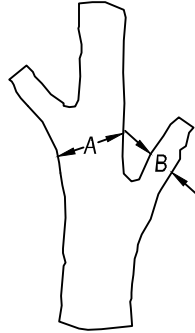
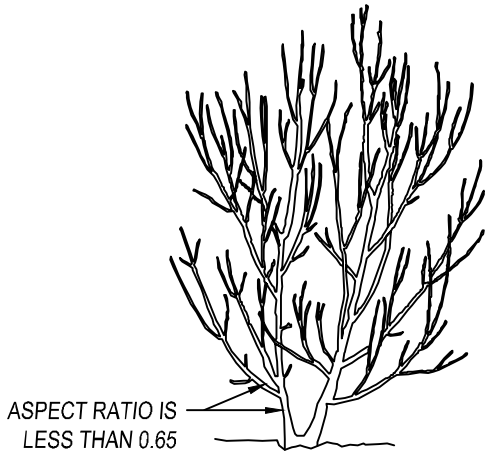

EXAMPLE		
A	B	ASPECT RATIO
1.50"	0.50"	0.33
2.50"	0.09"	0.36
2.00"	1.00"	0.50
2.50"	1.60"	0.64

ASPECT RATIO OF B:A LESS THAN 0.66 AS MEASURED 1" ABOVE THE TOP OF THE BRANCH UNION

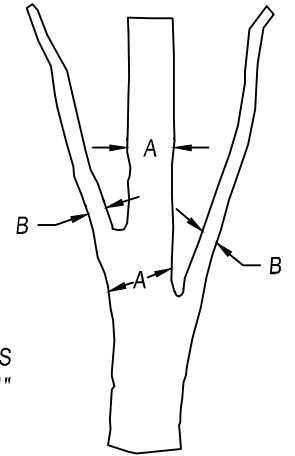

REJECTABLE

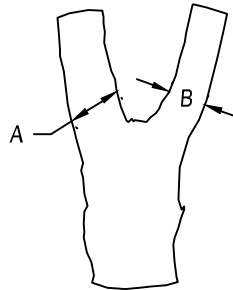

EXAMPLE		
A	B	ASPECT RATIO
2.50"	1.80"	0.72
2.0"	2.0"	1.0
2.5"	2.0"	0.80
4.0"	3.0"	0.75

ASPECT RATIO OF B:A GREATER THAN OR EQUAL TO 0.66 AS MEASURED 1" ABOVE THE TOP OF THE BRANCH UNION

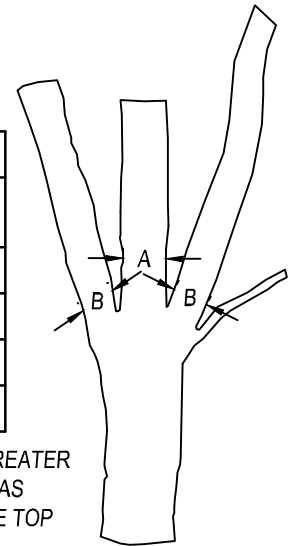

NOTES:

1. ASPECT RATIO SHALL BE LESS THAN 0.66 ON ALL BRANCH UNIONS. ASPECT RATIO IS THE DIAMETER OF BRANCH (B) DIVIDED BY THE DIAMETER OF THE TRUNK (A) AS MEASURED 1" ABOVE THE TOP OF THE BRANCH UNION.
2. ANY TREE NOT MEETING THE CROWN OBSERVATIONS DETAIL MAY BE REJECTED.



CITY COUNCIL APPROVAL: 01/24/2023

 APPROVED BY CITY ENGINEER

 APPROVED BY PUBLIC WORKS DIRECTOR

CROWN OBSERVATION - MULTI

PUBLIC IMPROVEMENT STANDARDS

L-34

REVISIONS

NAME	BY	DATE

ACCEPTABLE

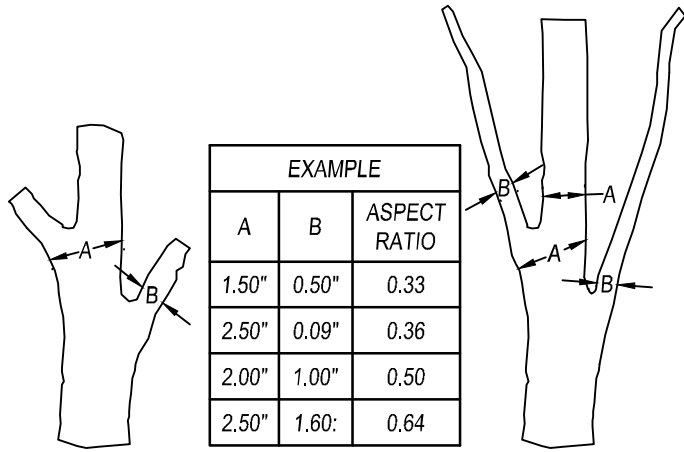
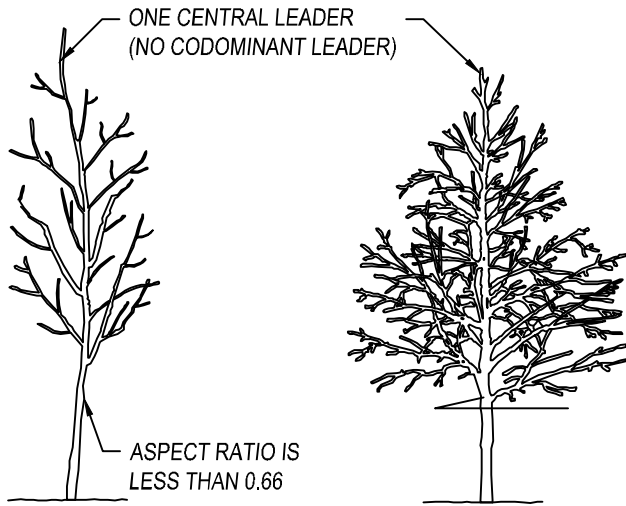

ASPECT RATIO OF B:A LESS THAN 0.66 AS MEASURED 1" ABOVE THE TOP OF THE BRANCH UNION

REJECTABLE

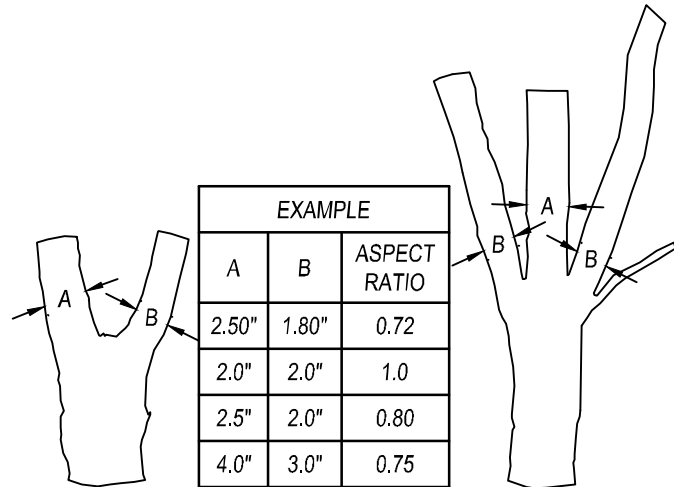
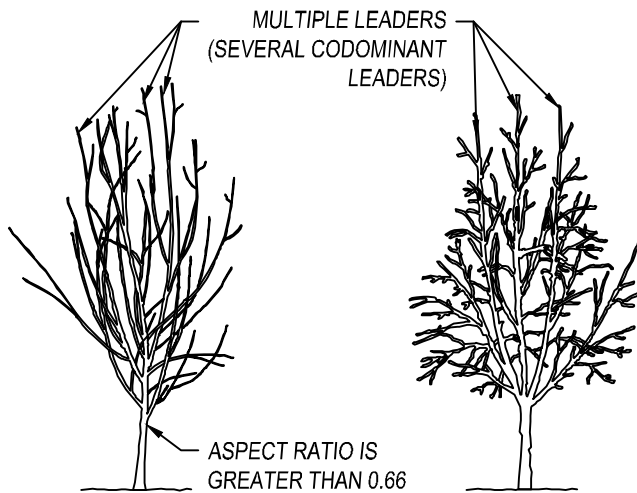

ASPECT RATIO OF B:A GREATER THAN OR EQUAL TO 0.66 AS MEASURED 1" ABOVE THE TOP OF THE BRANCH UNION.

NOTES:

- ASPECT RATIO SHALL BE LESS THAN 0.66 ON ALL BRANCH UNIONS. ASPECT RATIO IS THE DIAMETER OF BRANCH (B) DIVIDED BY THE DIAMETER OF THE TRUNK (A) AS MEASURED 1" ABOVE THE TOP OF THE BRANCH UNION.
- ANY TREE NOT MEETING THE CROWN OBSERVATIONS DETAIL MAY BE REJECTED.



CITY COUNCIL APPROVAL: 01/24/2023

APPROVED BY CITY ENGINEER

APPROVED BY PUBLIC WORKS DIRECTOR

CROWN OBSERVATION - HIGH BRANCHED

PUBLIC IMPROVEMENT STANDARDS

L-35

REVISIONS

NAME BY DATE

NAME	BY	DATE

ACCEPTABLE

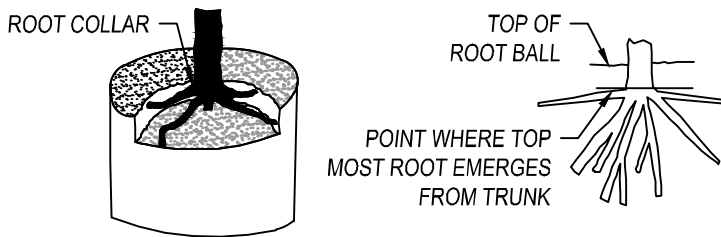

THE POINT WHERE TOP-MOST ROOT(S) EMERGES FROM THE TRUNK (ROOT COLLAR) SHOULD BE WITHIN THE TOP 2" OF SUBSTRATE. THE ROOT COLLAR AND THE ROOT BALL INTERIOR SHOULD BE FREE OF DEFECTS INCLUDING CIRCLING, KINKED, ASCENDING, AND STEM GIRDLING ROOTS. STRUCTURAL ROOTS SHALL REACH THE PERIPHERY NEAR THE TOP OF THE ROOT BALL.

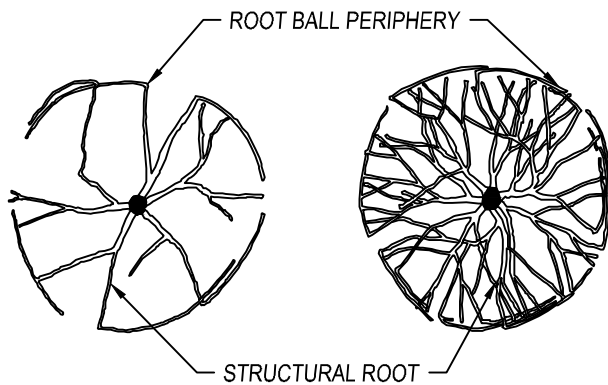

ROOTS RADIATE FROM TRUNK AND REACH SIDE OF ROOT BALL WITHOUT DEFLECTING DOWN OR AROUND.

REJECTABLE

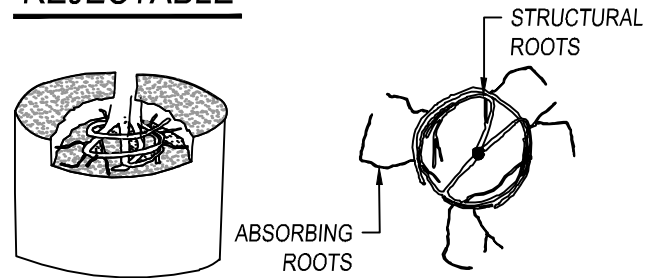

STRUCTURAL ROOTS CIRCLE INTERIOR OF ROOT BALL. NO STRUCTURAL ROOTS ARE HORIZONTAL AND REACH THE ROOT BALL PERIPHERY NEAR THE TOP OF THE ROOT BALL.

ONLY ABSORBING ROOTS REACH THE PERIPHERY NEAR THE TOP OF THE ROOT BALL. STRUCTURAL ROOTS MOSTLY WRAP OR ARE DEFLECTED ON THE ROOT BALL INTERIOR.

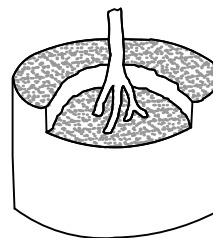

STRUCTURAL ROOTS DESCEND INTO ROOT BALL INTERIOR. NO STRUCTURAL ROOTS ARE HORIZONTAL AND REACH THE ROOT BALL PERIPHERY NEAR THE TOP OF THE ROOT BALL.

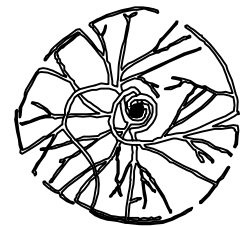

STRUCTURAL ROOTS CIRCLE AND DO NOT RADIATE FROM THE TRUNK.

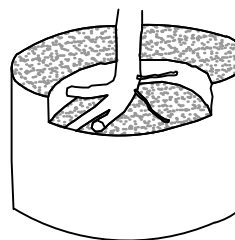

STRUCTURAL ROOTS PRIMARILY GROW TO ONE SIDE.

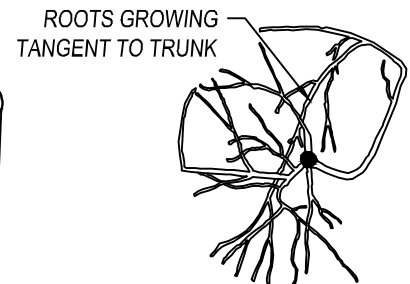

STRUCTURAL ROOTS MISSING FROM ONE SIDE, AND/OR GROW TANGENT TO TRUNK.

NOTES:

- OBSERVATIONS OF ROOTS SHALL OCCUR PRIOR TO ACCEPTANCE. ROOTS AND SUBSTRATE MAY BE REMOVED DURING THE OBSERVATION PROCESS; SUBSTRATE/SOIL SHALL BE REPLACED AFTER OBSERVATION HAS BEEN COMPLETED.
- SMALL ROOTS ($\frac{1}{4}$ " OR LESS) THAT GROW AROUND, UP, OR DOWN THE ROOT BALL PERIPHERY ARE CONSIDERED A NORMAL CONDITION IN CONTAINER PRODUCTION AND ARE ACCEPTABLE HOWEVER THEY SHOULD BE ELIMINATED AT THE TIME OF PLANTING. ROOTS ON THE PERIPHERY CAN BE REMOVED AT THE TIME OF PLANTING. (SEE ROOT BALL SHAVING CONTAINER DETAIL).
- SEE SPECIFICATIONS FOR OBSERVATION PROCESS AND REQUIREMENTS.



CITY COUNCIL APPROVAL: 01/24/2023

APPROVED BY CITY ENGINEER

APPROVED BY PUBLIC WORKS DIRECTOR

ROOT OBSERVATION - CONTAINER

PUBLIC IMPROVEMENT STANDARDS

L-36

REVISIONS

NAME	BY	DATE

SECTION VIEW

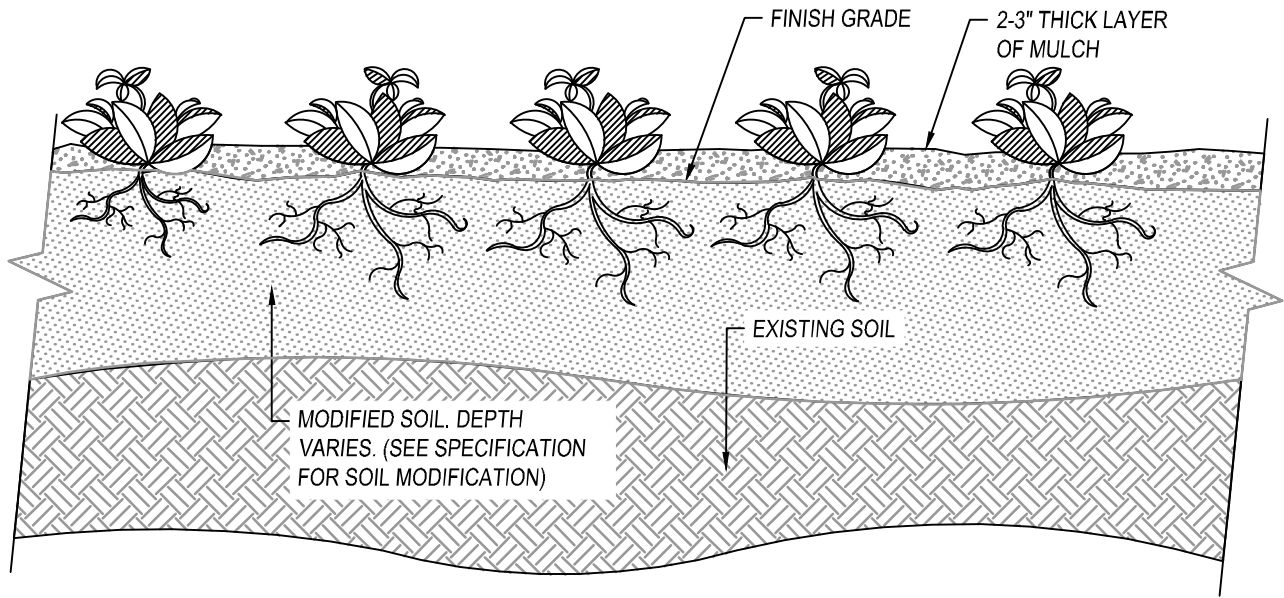

PLAN VIEW

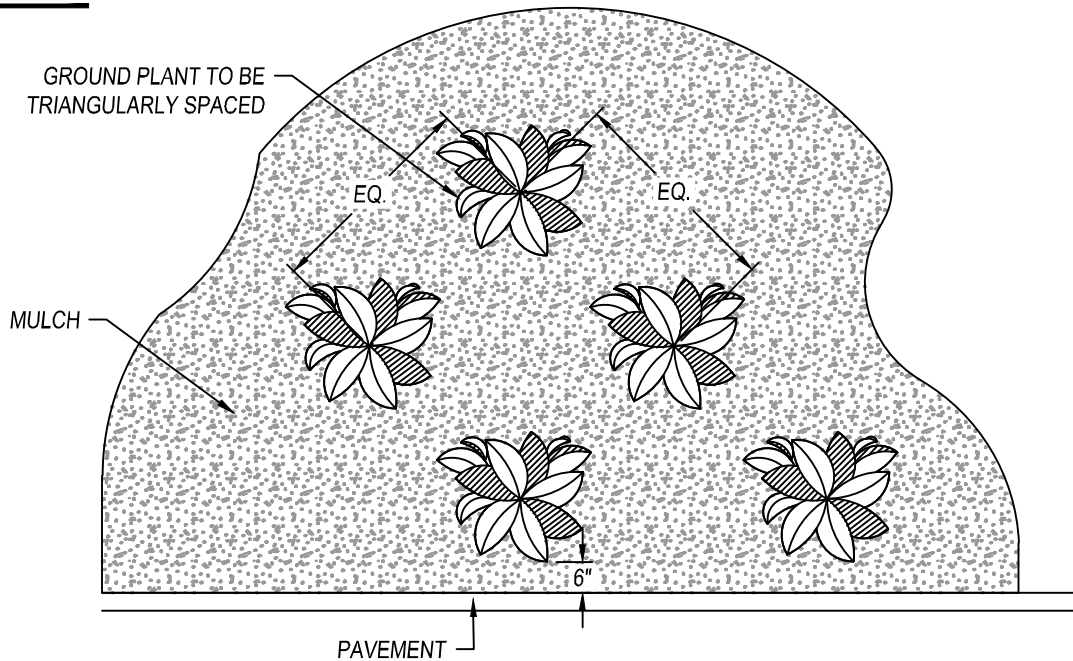

NOTES:

1. SEE PLANTING LEGEND FOR GROUNDCOVER SPECIES, SIZE, AND SPACING DIMENSION.
2. SMALL ROOTS (1/4" OR LESS) THAT GROW AROUND, UP, OR DOWN THE ROOT BALL PERIPHERY ARE CONSIDERED A NORMAL CONDITION IN CONTAINER PRODUCTION AND ARE ACCEPTABLE HOWEVER THEY SHOULD BE ELIMINATED AT THE TIME OF PLANTING. ROOTS ON THE PERIPHERY CAN BE REMOVED AT THE TIME OF PLANTING. (SEE ROOT BALL SHAVING CONTAINER DETAIL).
3. SETTLE SOIL AROUND ROOT BALL OF EACH GROUNDCOVER PRIOR TO MULCHING.



CITY COUNCIL APPROVAL: 01/24/2023

APPROVED BY CITY ENGINEER

APPROVED BY PUBLIC WORKS DIRECTOR

GROUNDCOVER

PUBLIC IMPROVEMENT STANDARDS

L-37

REVISIONS

NAME	BY	DATE

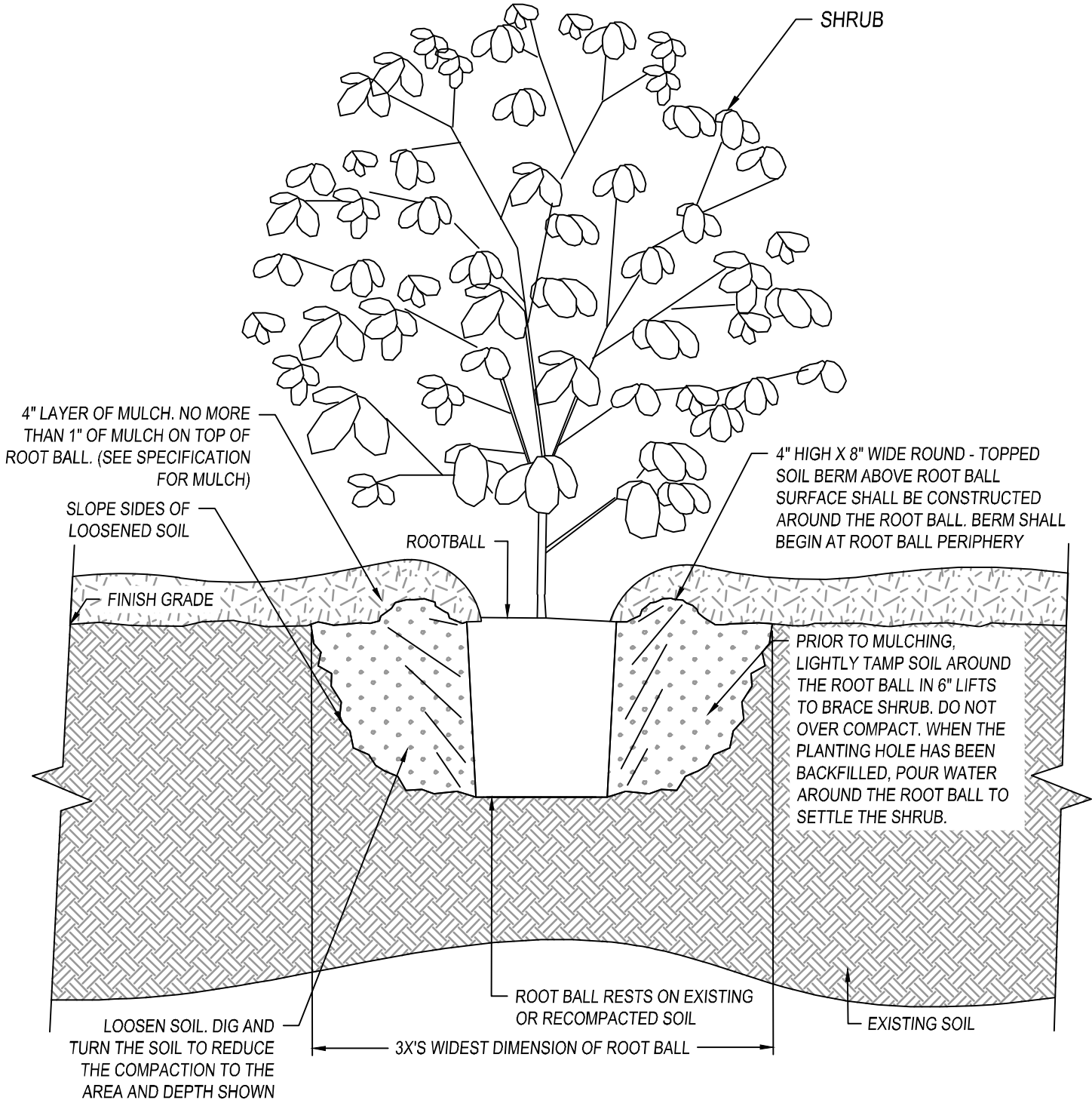

SECTION VIEW

NOTES:

1. SHRUBS SHALL BE OF QUALITY PRESCRIBED IN THE ROOT OBSERVATIONS DETAIL AND SPECIFICATIONS.
2. SEE SPECIFICATIONS FOR FURTHER REQUIREMENTS RELATED TO THIS DETAIL.



CITY COUNCIL APPROVAL: 01/24/2023

[Signature]
APPROVED BY CITY ENGINEER

[Signature]
APPROVED BY PUBLIC WORKS DIRECTOR

SHRUB - UNMODIFIED SOIL

PUBLIC IMPROVEMENT STANDARDS

L-38		
REVISIONS		
NAME	BY	DATE

NOTES:

1. SHRUBS SHALL BE OF QUALITY AS PRESCRIBED IN THE ROOT OBSERVATIONS DETAIL AND SPECIFICATION.
2. SEE SPECIFICATIONS FOR FURTHER REQUIREMENTS RELATED TO THIS DETAIL.

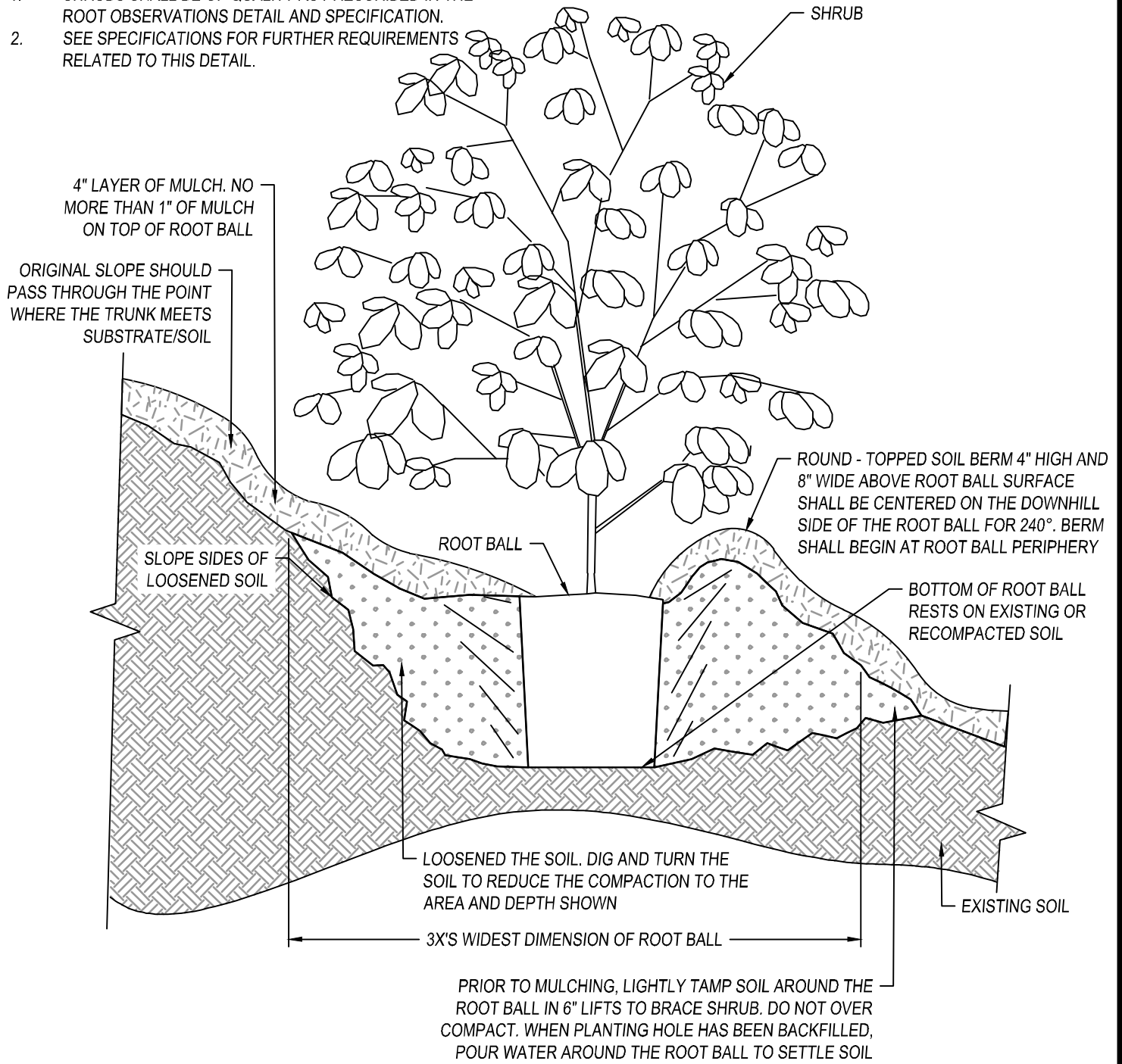

SECTION VIEW



CITY COUNCIL APPROVAL: 01/24/2023

[Signature]
APPROVED BY CITY ENGINEER

[Signature]
APPROVED BY PUBLIC WORKS DIRECTOR

SHRUB ON SLOPE (5% TO 50%)

PUBLIC IMPROVEMENT STANDARDS

L-39

REVISIONS

NAME	BY	DATE

NOTES:

1. TREES SHALL BE OF QUALITY PRESCRIBED IN CROWN OBSERVATIONS AND ROOT OBSERVATIONS DETAILS AND SPECIFICATIONS.
2. SEE SPECIFICATIONS FOR FURTHER REQUIREMENTS RELATED TO THIS DETAIL.

CENTRAL LEADER (SEE CROWN OBSERVATION DETAIL)

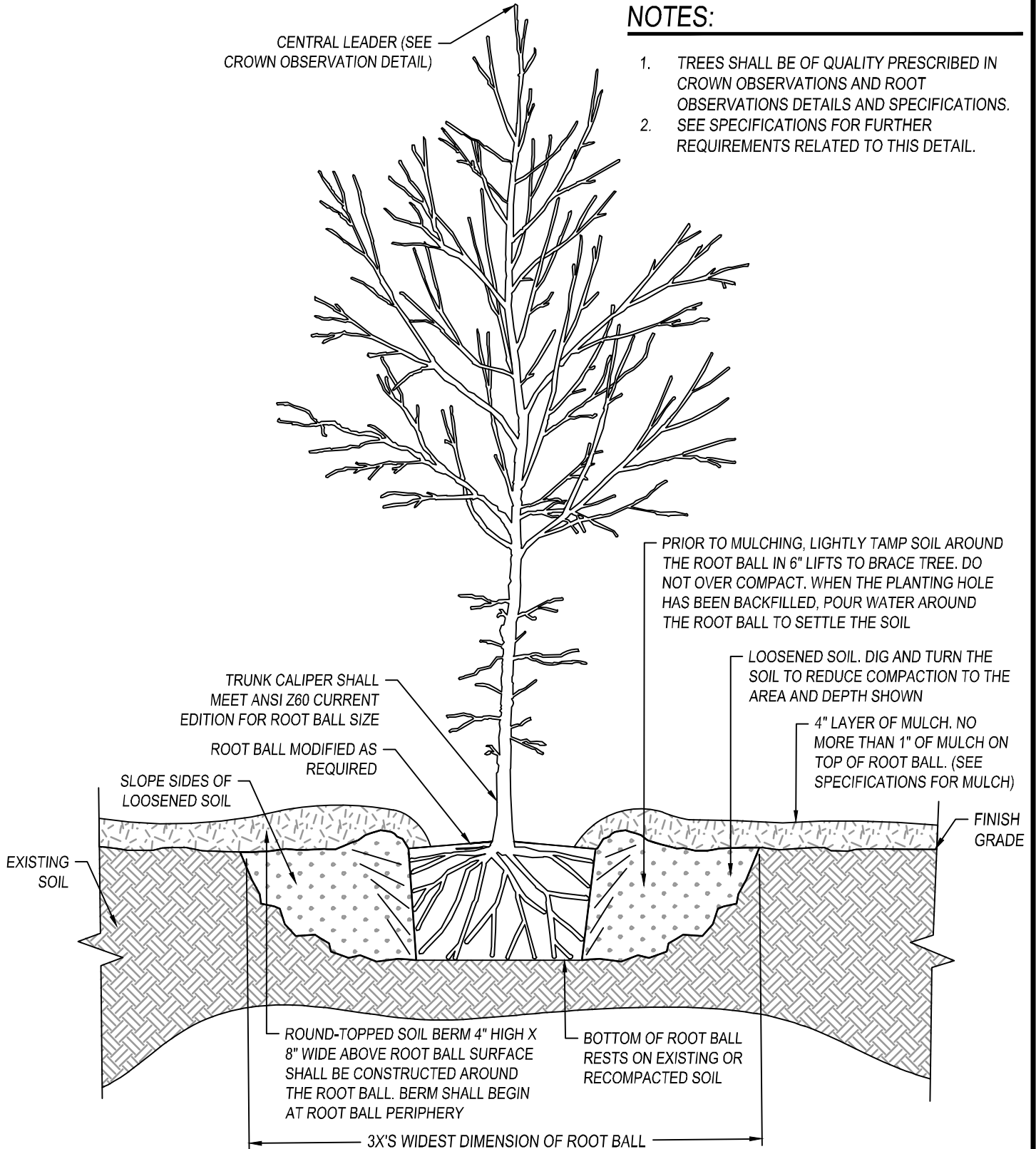

SECTION VIEW



CITY COUNCIL APPROVAL: 01/24/2023
 APPROVED BY CITY ENGINEER
 APPROVED BY PUBLIC WORKS DIRECTOR

TREE WITH BERM
PUBLIC IMPROVEMENT STANDARDS

L-40		
REVISIONS		
NAME	BY	DATE

NOTES:

1. TREES SHALL BE OF QUALITY PRESCRIBED IN CROWN OBSERVATIONS AND ROOT OBSERVATIONS DETAILS AND SPECIFICATIONS.
2. SEE SPECIFICATIONS FOR FURTHER REQUIREMENTS RELATED TO THIS DETAIL.

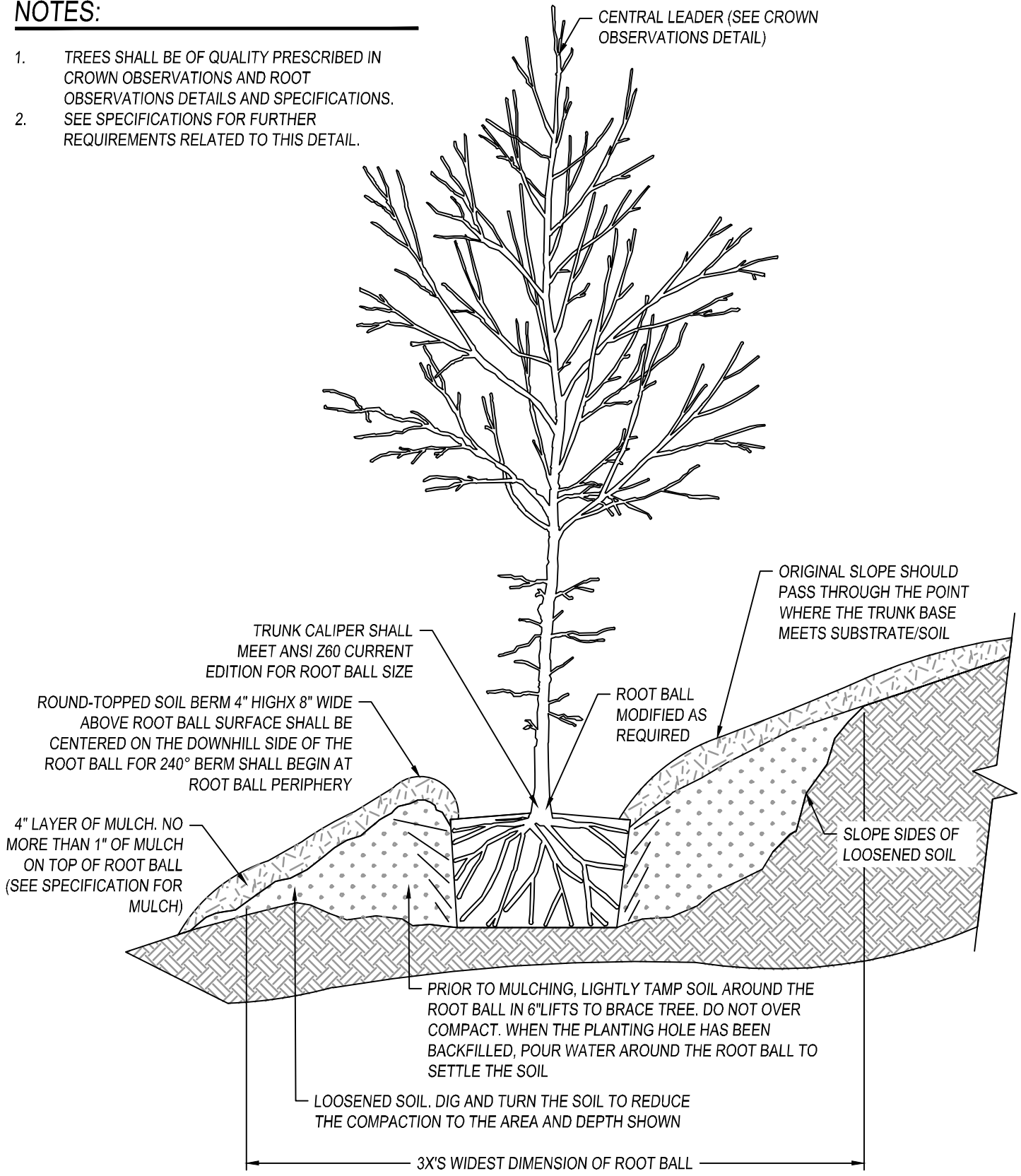

SECTION VIEW



CITY COUNCIL APPROVAL: 01/24/2023

[Signature]
APPROVED BY CITY ENGINEER

[Signature]
APPROVED BY PUBLIC WORKS DIRECTOR

TREE ON SLOPE (5% TO 50%)

PUBLIC IMPROVEMENT STANDARDS

L-41

REVISIONS

NAME	BY	DATE

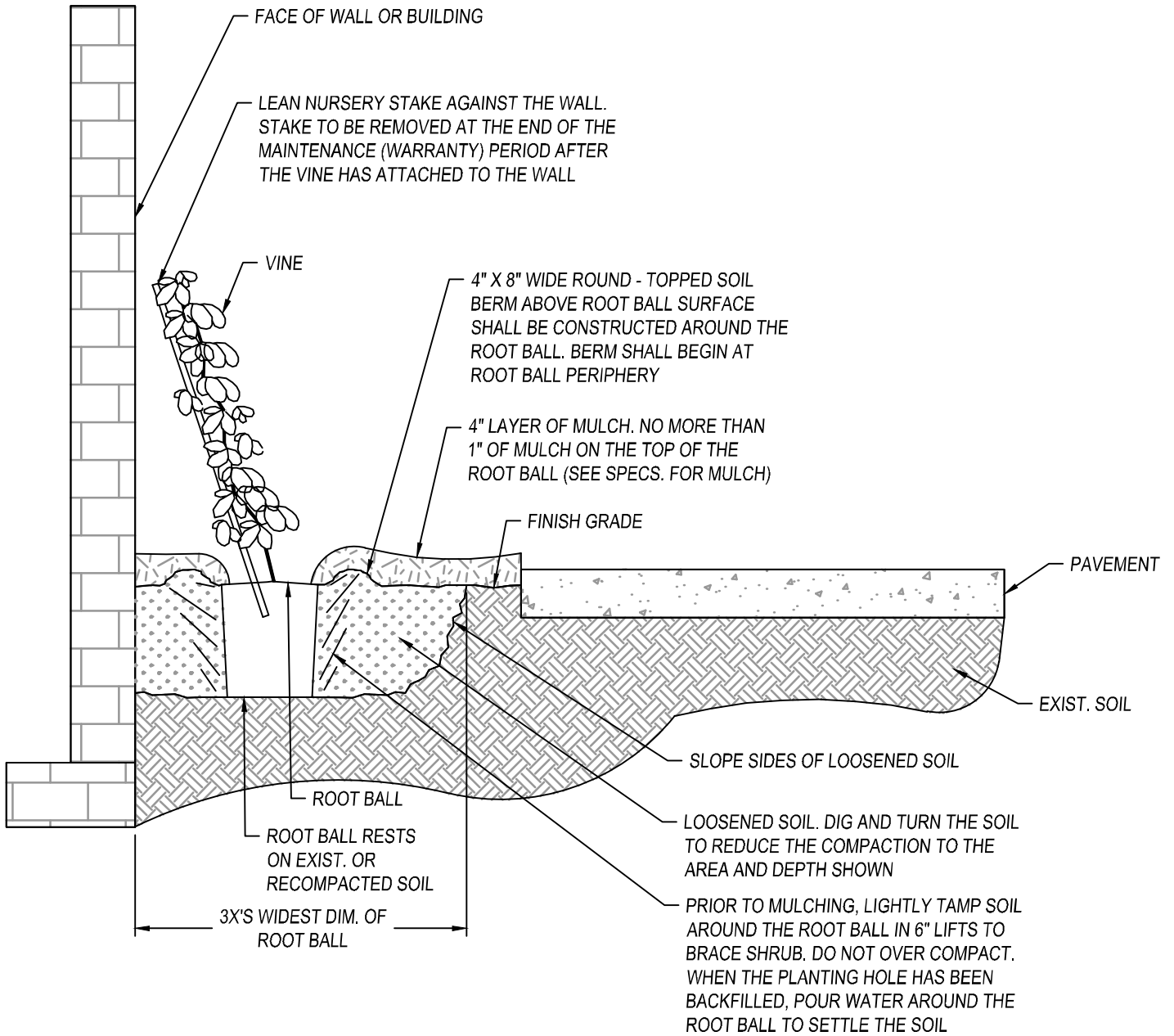

NOTES:

1. VINES SHALL BE OF QUALITY AS PRESCRIBED IN THE ROOT OBSERVATIONS DETAIL AND SPECIFICATIONS.
2. SEE SPECIFICATIONS FOR FURTHER REQUIREMENTS RELATED TO THIS DETAIL.



CITY COUNCIL APPROVAL: 01/24/2023
 APPROVED BY CITY ENGINEER
 APPROVED BY PUBLIC WORKS DIRECTOR

VINE - UNMODIFIED SOIL

PUBLIC IMPROVEMENT STANDARDS

L-42

REVISIONS

NAME	BY	DATE

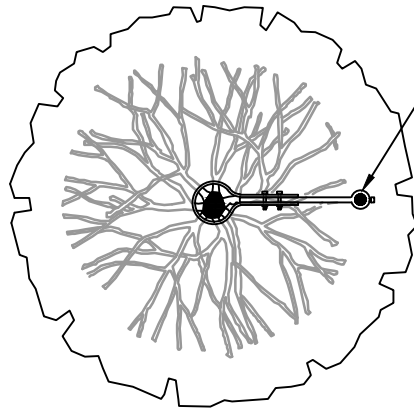

PLAN VIEW

1" X 9' SINGLE METAL STAKE WITH METAL ARM BAR SECURED TO STAKE AND RUBBER STRAP AROUND TRUNK

PREVAILING WIND

REMOVE NURSERY STAKE. IF CENTRAL LEADER NEEDS TO BE STRAIGHTENED OR HELD ERECT, IT IS ACCEPTABLE TO ATTACH A 1/2" X 8' BAMBOO POLE TO THE CENTRAL LEADER AND TRUNK

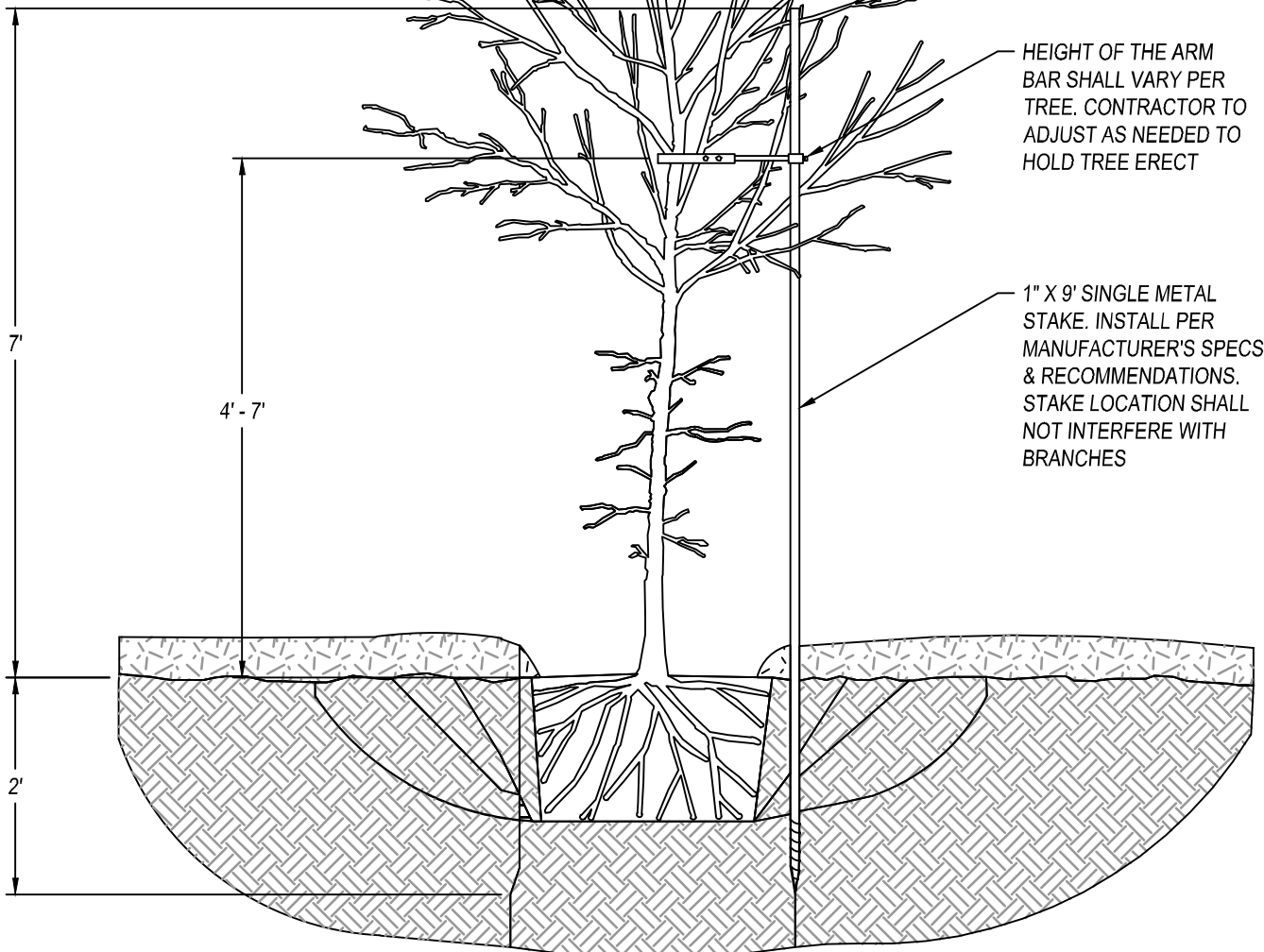

SECTION VIEW

HEIGHT OF THE ARM BAR SHALL VARY PER TREE. CONTRACTOR TO ADJUST AS NEEDED TO HOLD TREE ERECT

1" X 9' SINGLE METAL STAKE. INSTALL PER MANUFACTURER'S SPECS. & RECOMMENDATIONS. STAKE LOCATION SHALL NOT INTERFERE WITH BRANCHES



CITY COUNCIL APPROVAL: 01/24/2023

[Signature]
APPROVED BY CITY ENGINEER

[Signature]
APPROVED BY PUBLIC WORKS DIRECTOR

TREE STAKING - SINGLE METAL STAKE

PUBLIC IMPROVEMENT STANDARDS

L-43

REVISIONS

NAME	BY	DATE

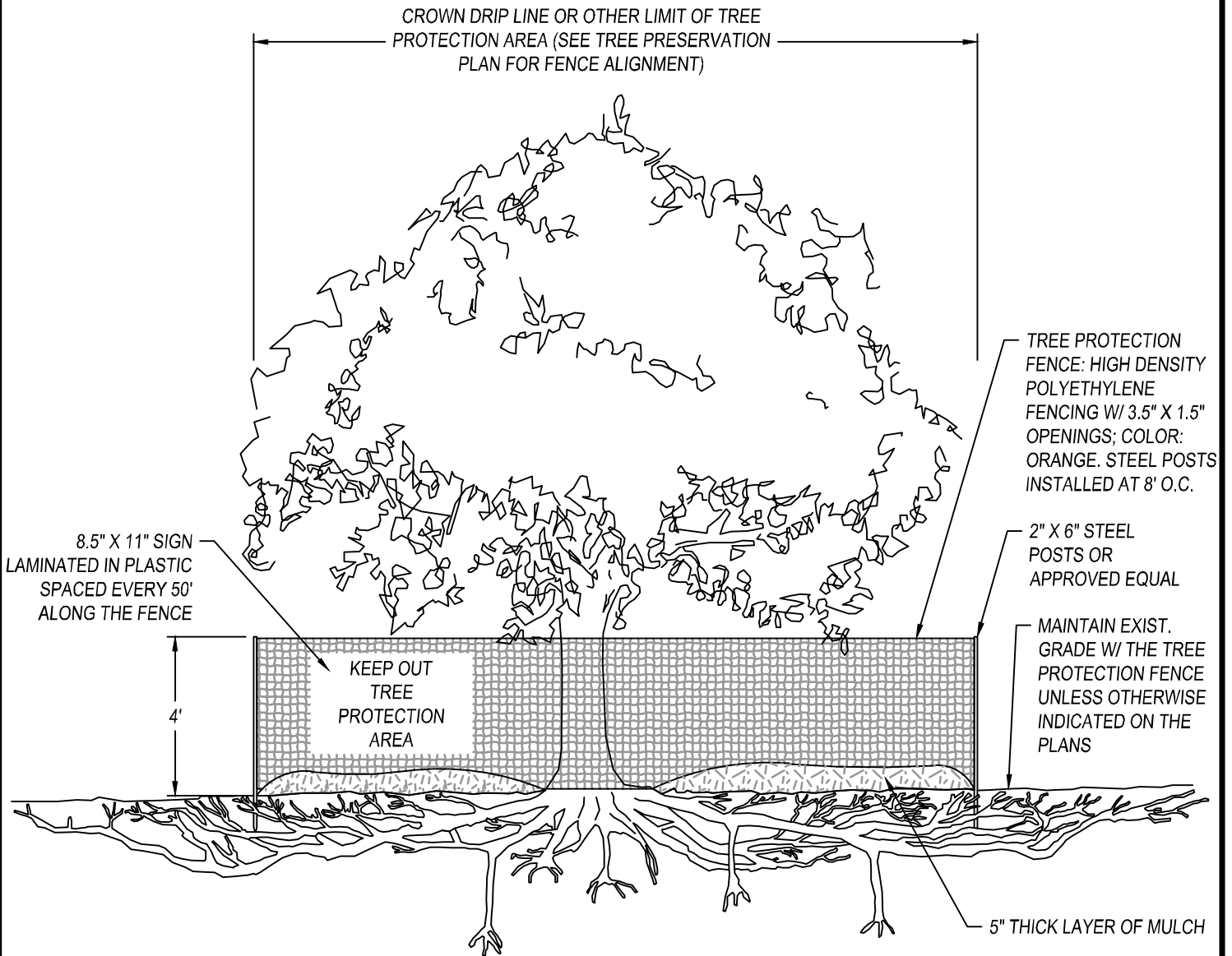

SECTION VIEW

NOTES:

1. SEE SPECIFICATIONS FOR ADDITIONAL TREE PROTECTION REQUIREMENTS.
2. IF THERE IS NO EXISTING IRRIGATION, SEE SPECIFICATIONS FOR WATERING REQUIREMENTS.
3. NO PRUNING SHALL BE PERFORMED EXCEPT BY APPROVED ARBORIST.
4. NO EQUIPMENT SHALL OPERATE INSIDE THE PROTECTIVE FENCING INCLUDING DURING FENCE INSTALLATION AND REMOVAL.
5. SEE SITE PREPARATION PLAN FOR ANY MODIFICATIONS WITH THE TREE PROTECTION AREA.



CITY COUNCIL APPROVAL: 01/24/2023

[Signature]
APPROVED BY CITY ENGINEER

[Signature]
APPROVED BY PUBLIC WORKS DIRECTOR

TREE PROTECTION

PUBLIC IMPROVEMENT STANDARDS

L-44

REVISIONS

NAME	BY	DATE

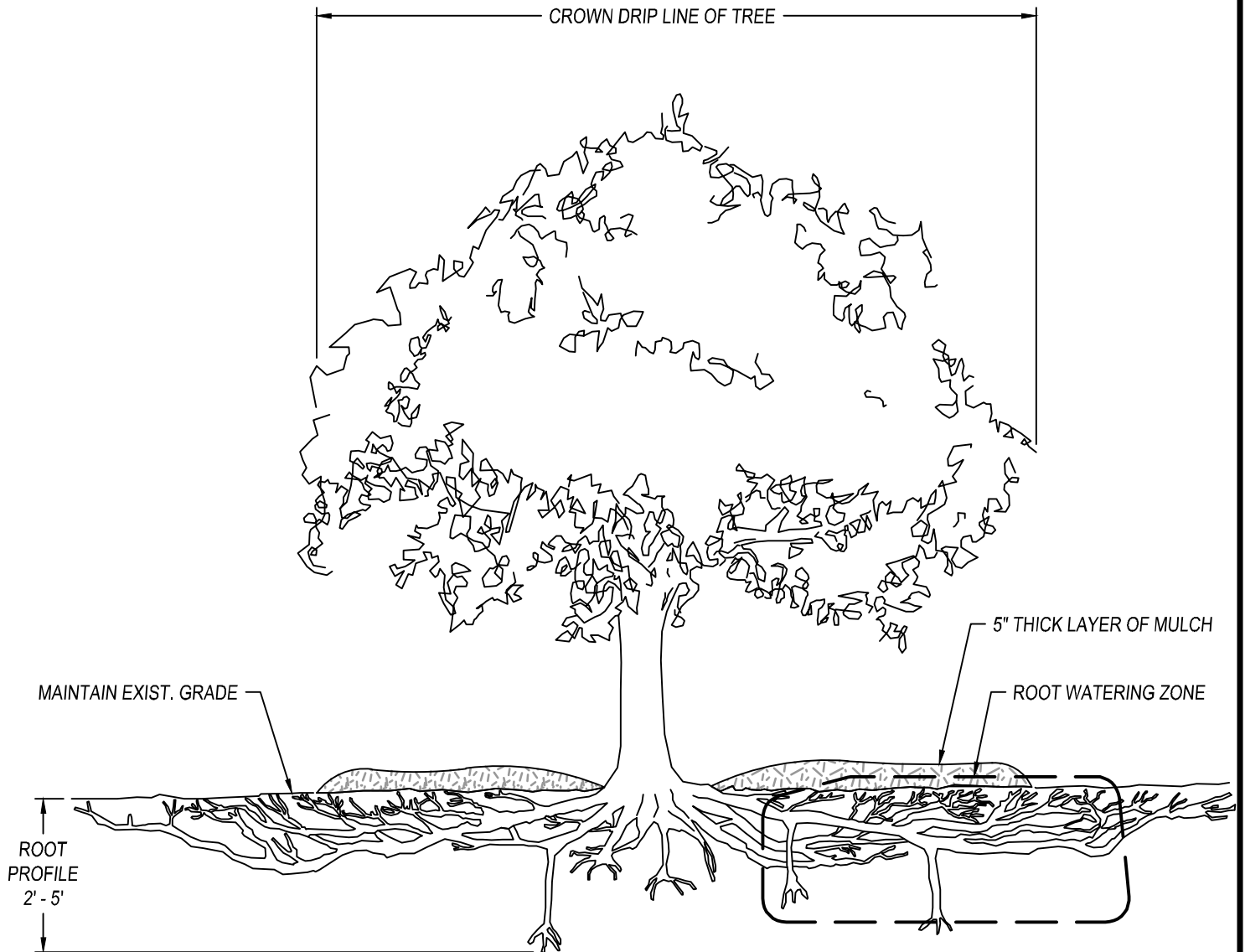

SECTION VIEW

NOTES:

1. APPLY 10 GALLONS OF WATER PER 1" OF TRUNK SIZE MEASURED AT DIAMETER BREAST HEIGHT EVERY 2-3 WEEKS.
2. WATER APPLICATION SHOULD BE DETERMINED BY IRRIGATION EMITTER. IE. OVERHEAD, DRIP, OR HAND HELD.
3. LONGER, SLOWER APPLICATION OF WATER IS IDEAL WHICH ALLOWS WATER TO SLOWLY PERCOLATE INTO THE TREES ROOT ZONE AND BE UTILIZED BY THE TREES ROOT SYSTEM.
4. DO NOT SPRAY THE TREE TRUNK OR APPLY WATER DIRECTLY ADJACENT TO THE TRUNK.



CITY COUNCIL APPROVAL: 01/24/2023

[Signature]
APPROVED BY CITY ENGINEER

[Signature]
APPROVED BY PUBLIC WORKS DIRECTOR

WATERING MATURE TREES

PUBLIC IMPROVEMENT STANDARDS

L-45

REVISIONS

NAME	BY	DATE

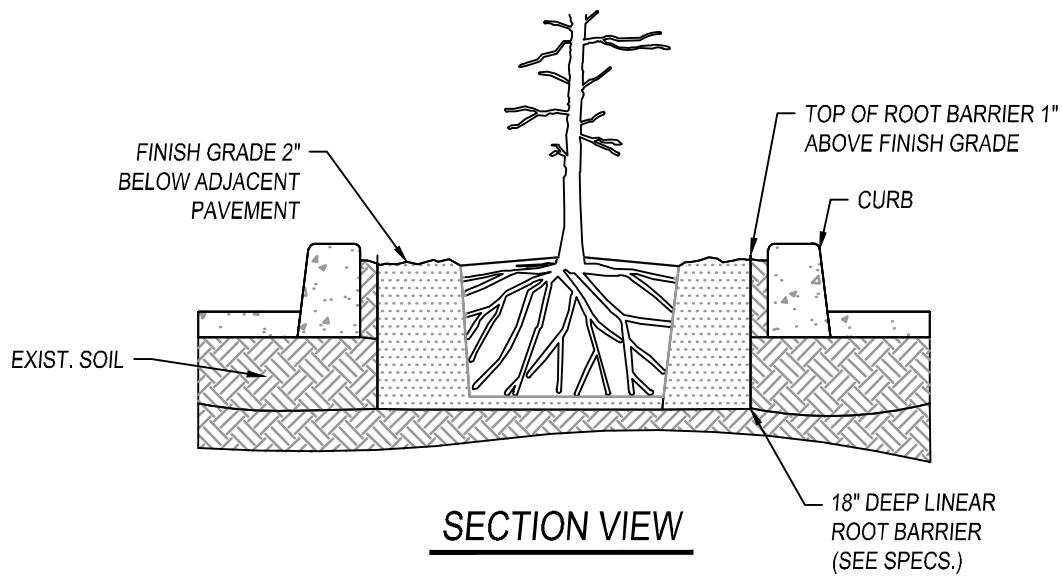
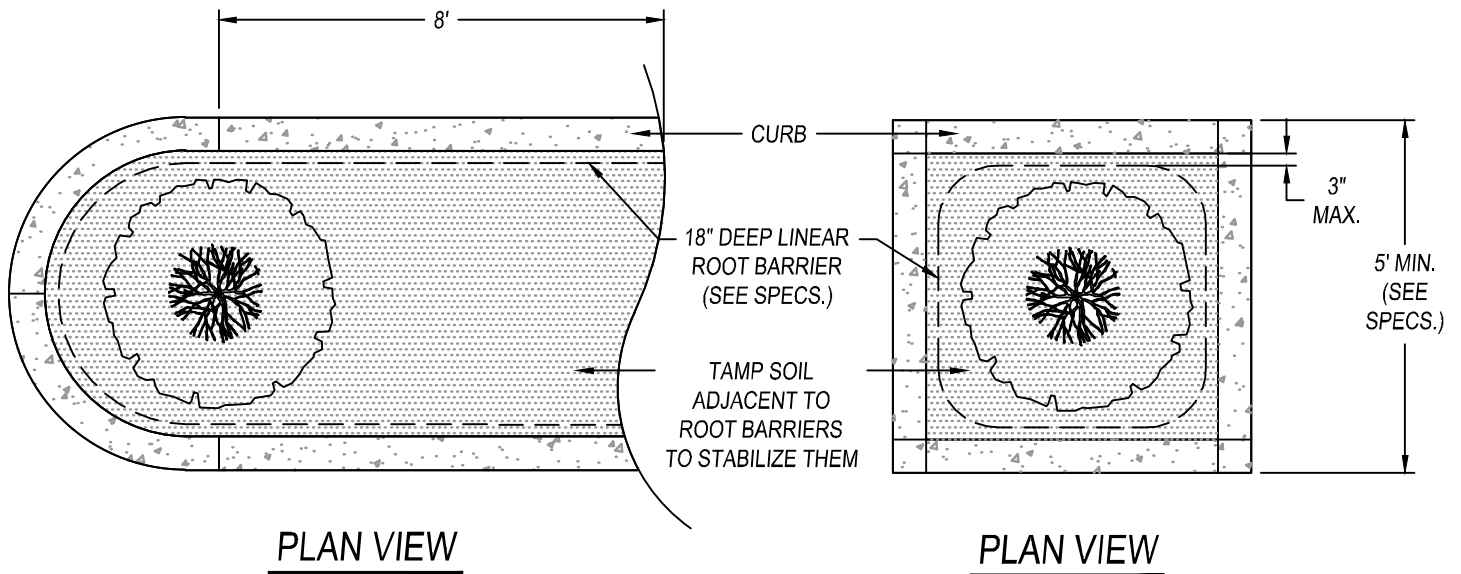

NOTES:

1. ROOT BARRIERS SHALL BE INSTALLED PER MANUFACTURER'S SPECIFICATIONS AND RECOMMENDATIONS.
2. ROOT BARRIERS SHALL BE INSTALLED WHEN ROOT BALL IS LOCATED WITHIN 8' OF PAVEMENT.



CITY COUNCIL APPROVAL: 01/24/2023

[Signature]
APPROVED BY CITY ENGINEER

[Signature]
APPROVED BY PUBLIC WORKS DIRECTOR

LINEAR ROOT BARRIERS - PARKING LOT ISLANDS

PUBLIC IMPROVEMENT STANDARDS

L-46		
REVISIONS		
NAME	BY	DATE

NOTES:

1. ROOT BARRIERS SHALL BE INSTALLED PER MANUFACTURER'S SPECIFICATIONS AND RECOMMENDATIONS.
2. ROOT BARRIERS SHALL BE INSTALLED WHEN ROOT BALL IS LOCATED WITHIN 8' OF CURB, PAVEMENT, WALL OR OTHER HARDSCAPE.

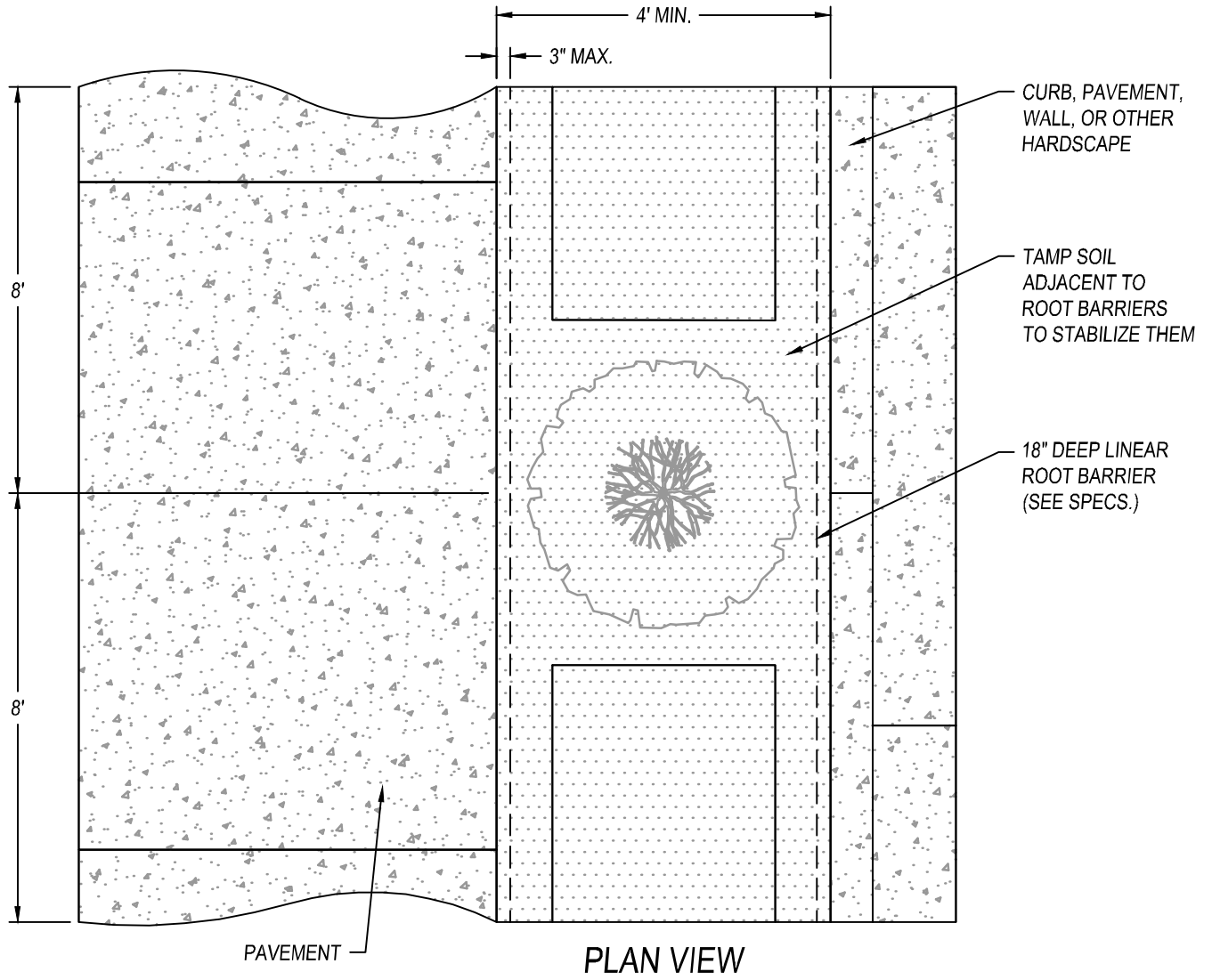
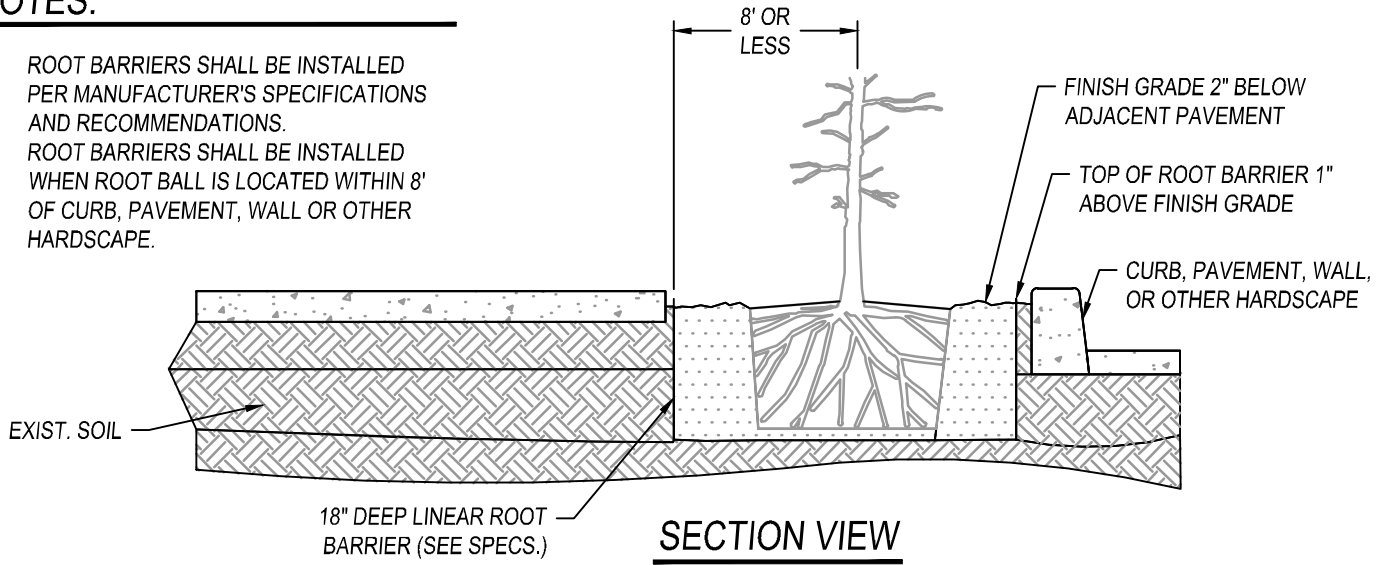

CITY COUNCIL APPROVAL: 01/24/2023

APPROVED BY CITY ENGINEER

APPROVED BY PUBLIC WORKS DIRECTOR

LINEAR ROOT BARRIERS

PUBLIC IMPROVEMENT STANDARDS

L-47

REVISIONS

NAME	BY	DATE

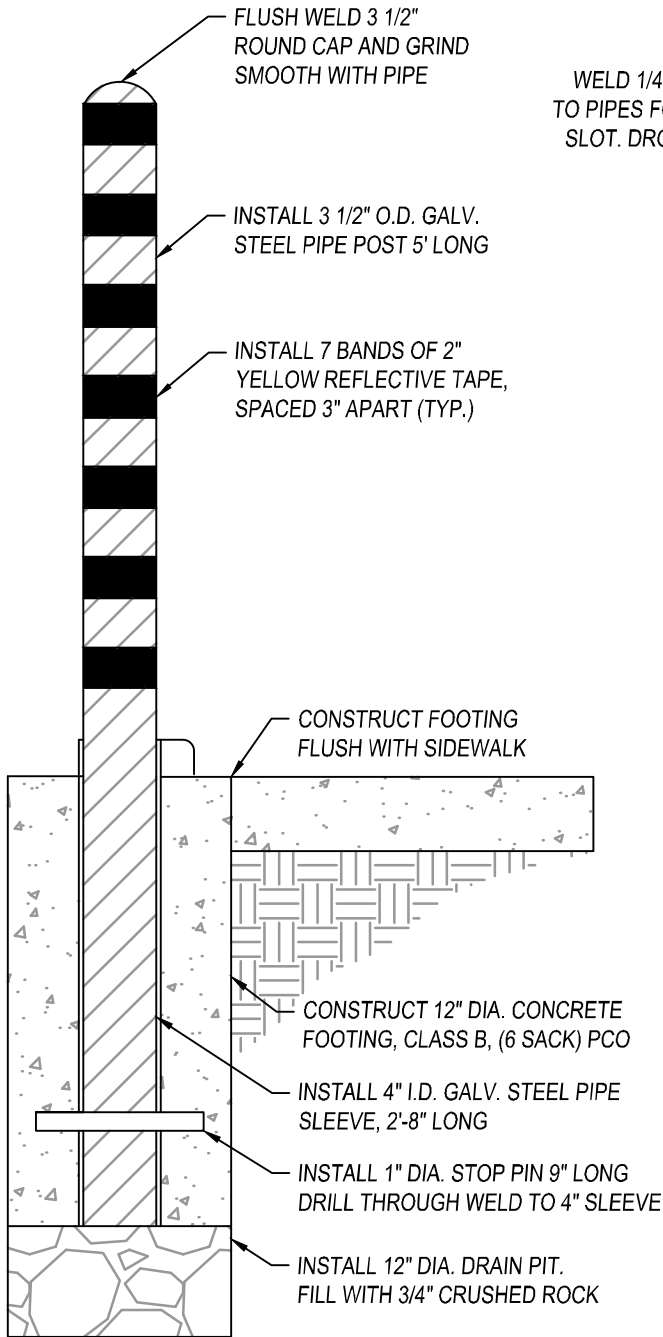

WELD 1/4" X 2" X 2" STEEL PLATES TO PIPES FOR LOCK TAB AND DROP SLOT. DROP SLOT TO BE 1/2" WIDE

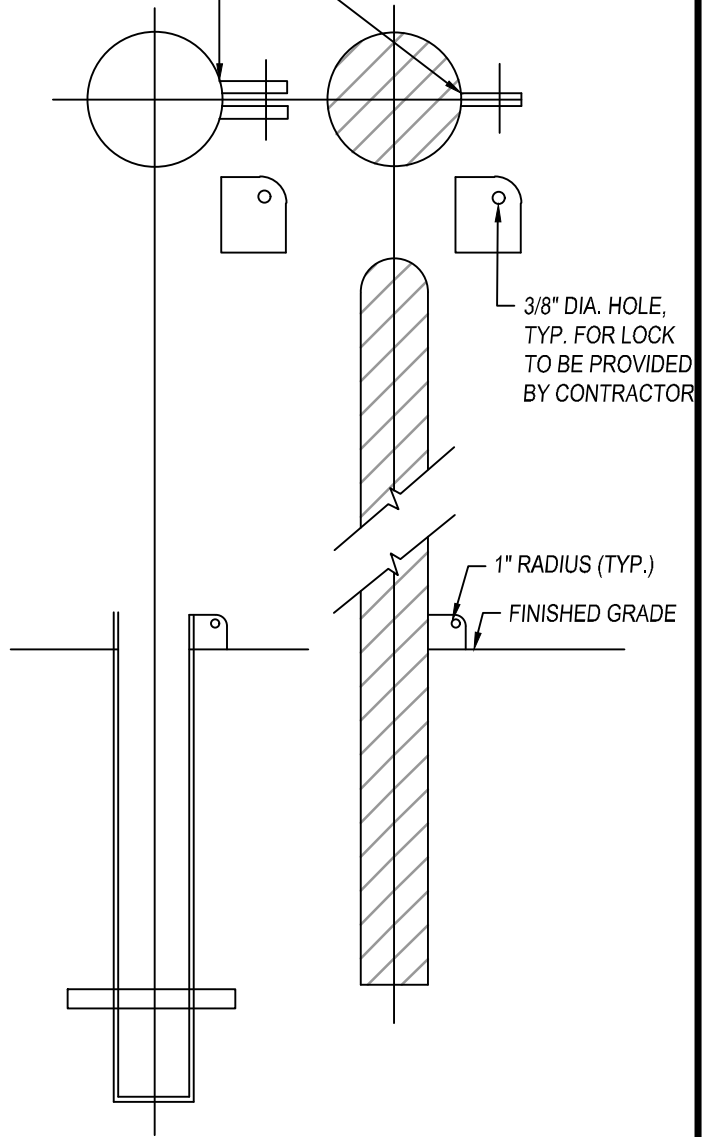

LOCKING DETAIL



CITY COUNCIL APPROVAL: 01/24/2023

APPROVED BY CITY ENGINEER

APPROVED BY PUBLIC WORKS DIRECTOR

GALVANIZED STEEL BOLLARD

PUBLIC IMPROVEMENT STANDARDS

M-1

REVISIONS

NAME	BY	DATE

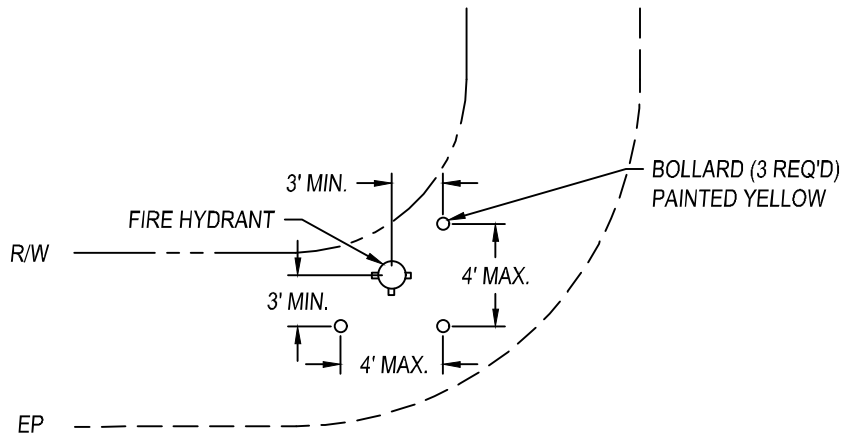

TYPICAL LAYOUT FOR FIRE HYDRANT NEAR STREET INTERSECTION

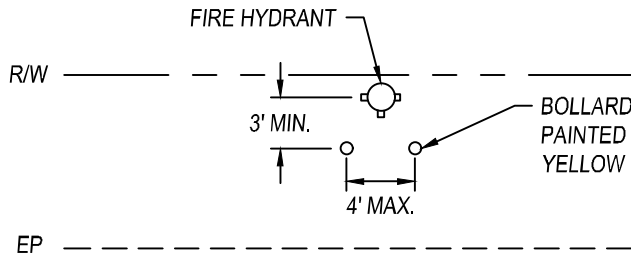

TYPICAL LAYOUT FOR FIRE HYDRANT >50 FROM STREET INTERSECTION

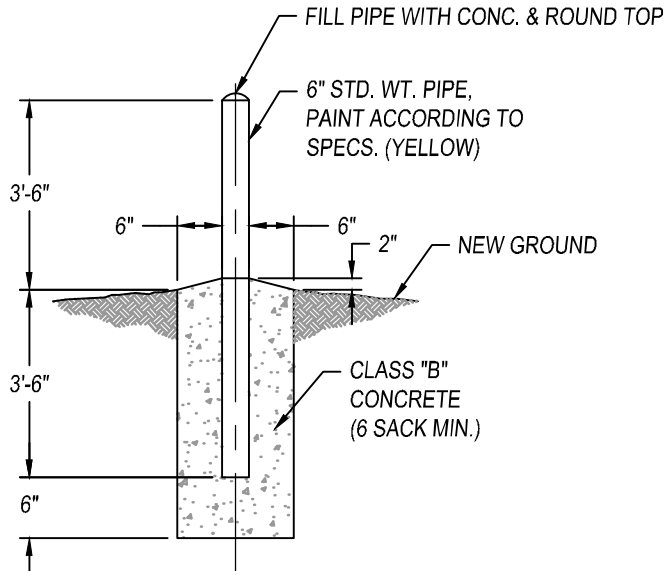

BOLLARD



CITY COUNCIL APPROVAL: 01/24/2023
 APPROVED BY CITY ENGINEER
 APPROVED BY PUBLIC WORKS DIRECTOR

**TYPICAL FIRE HYDRANT
 BOLLARD LOCATION
 PUBLIC IMPROVEMENT STANDARDS**

M-2		
REVISIONS		
NAME	BY	DATE

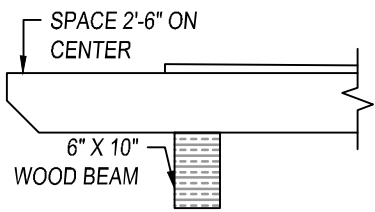
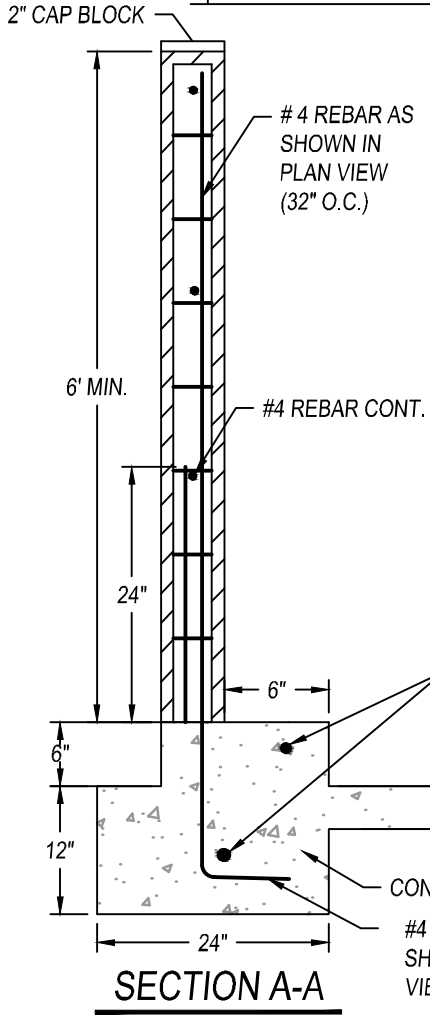
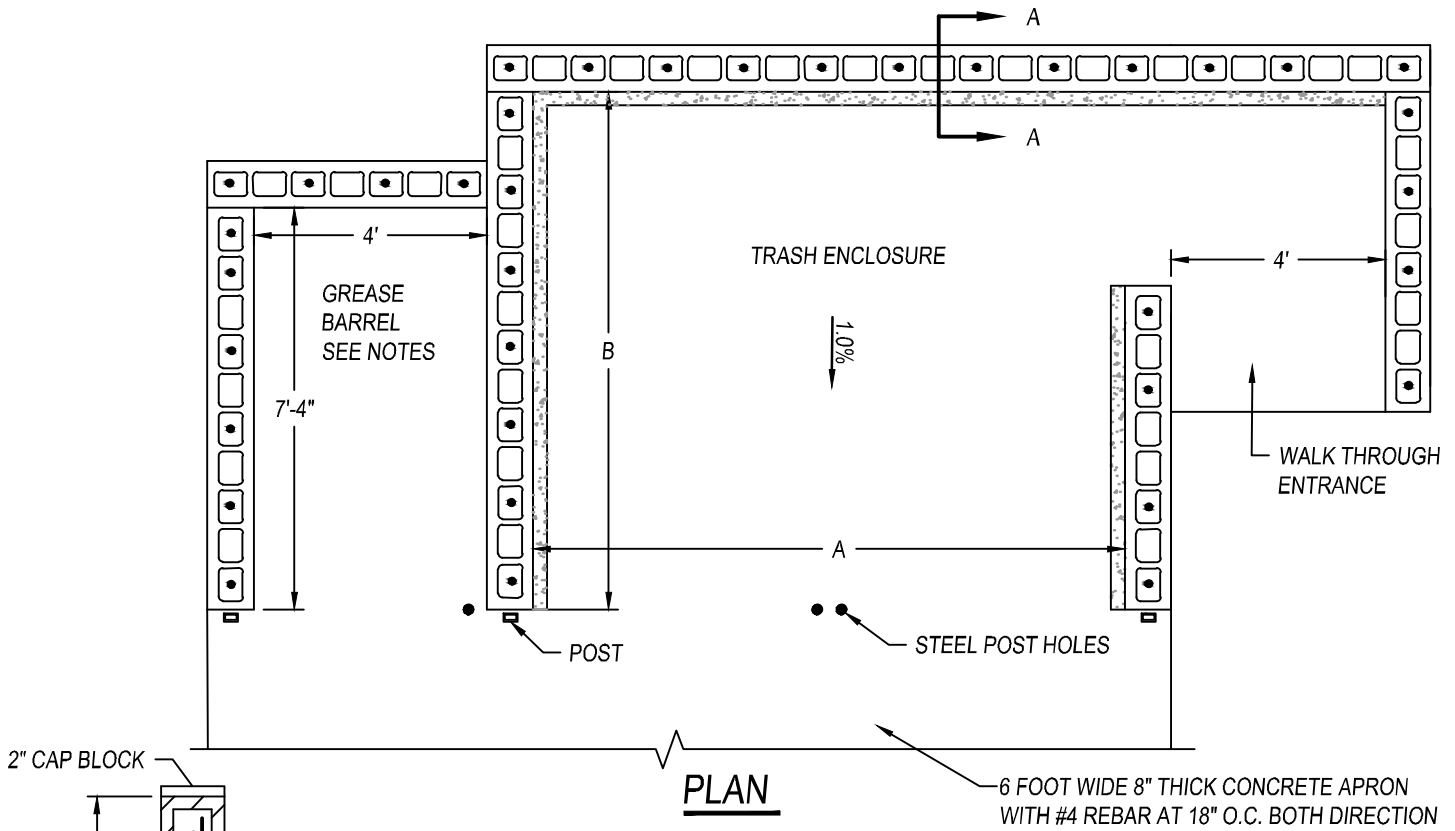

INSIDE DIMENSIONS OF THE ENCLOSURE		
	A	B
TYPE I	10'-8"	10'-4"
TYPE II	14'-8"	10'-4"
TYPE III	18'-8"	10'-4"
TYPE IV	14'-8"	15'-4"
TYPE V	18'-8"	15'-4"

- NOTES:**
1. THE GROUND SHALL BE SLOPED AWAY FROM THE WALLS AT A MAXIMUM SLOPE OF 1%.
 2. LOCATION OF THE BIN SHALL BE APPROVED BY THE CITY.
 3. BUILDING PERMIT SHALL BE OBTAINED FROM THE CITY AND ONCE COMPLETED INSPECTED BY THE CITY.
 4. ALL ENCLOSURE TO BE CONSTRUCTED 6"X8X16" 2000 PSI CONCRETE BLOCK TO MATCH BUILDING FEATURES.
 5. GREASE BARREL ENCLOSURES ARE REQUIRED FOR ALL RESTAURANTS AND FOOD SERVICE ESTABLISHMENT.
 6. FOOTINGS AND FLOORS SHALL BE CONCRETE 2500 PSI @28 DAYS, INCLUDING GATE POST FOOTINGS.
 7. THE ROOF SHALL HAVE A MINIMUM SLOPE OF 2% SLOPING TOWARDS THE BACK OF THE ENCLOSURE.
 8. FINISH PAD ELEVATION SHALL MATCH EXISTING ELEVATION.



CITY COUNCIL APPROVAL: 01/24/2023

APPROVED BY CITY ENGINEER

APPROVED BY PUBLIC WORKS DIRECTOR

TRASH BIN BLOCK ENCLOSURE

PUBLIC IMPROVEMENT STANDARDS

M-3		
REVISIONS		
NAME	BY	DATE

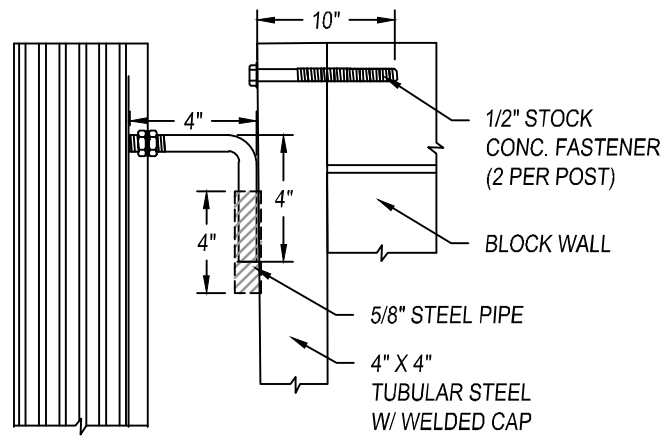
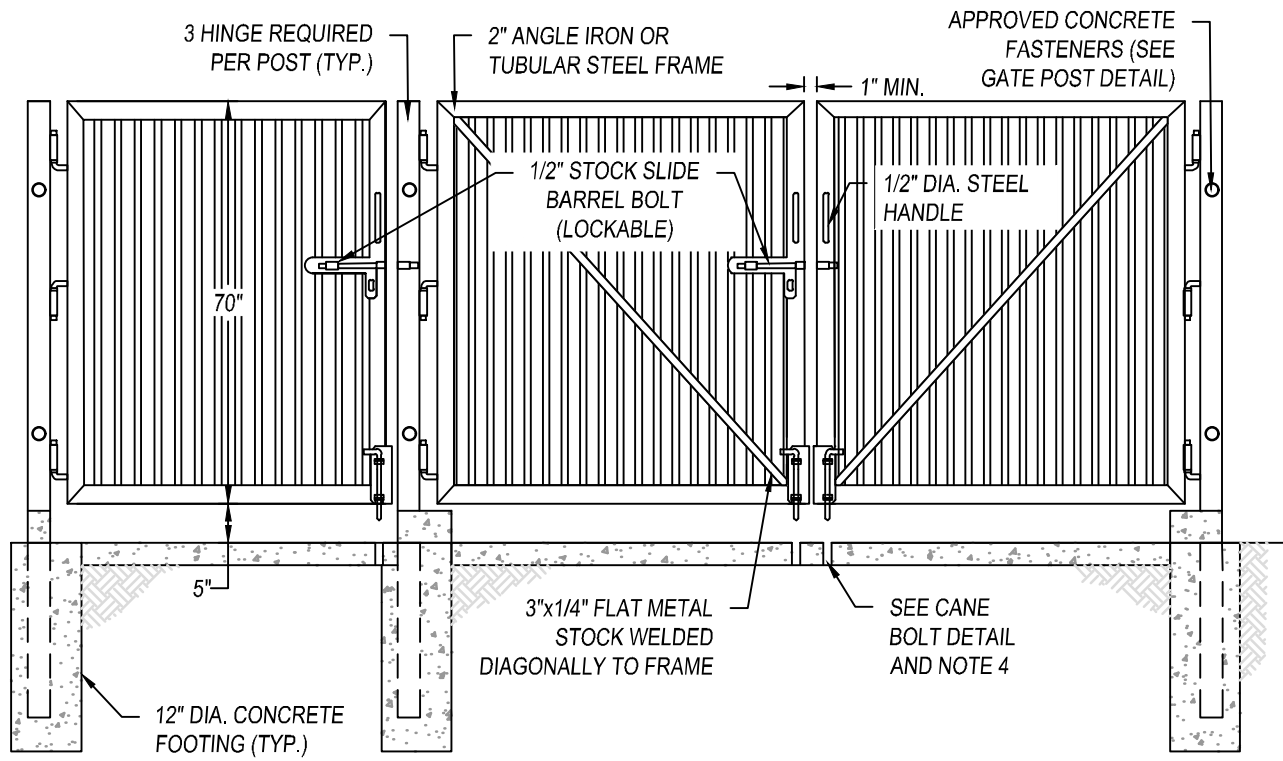

GATE POST DETAIL

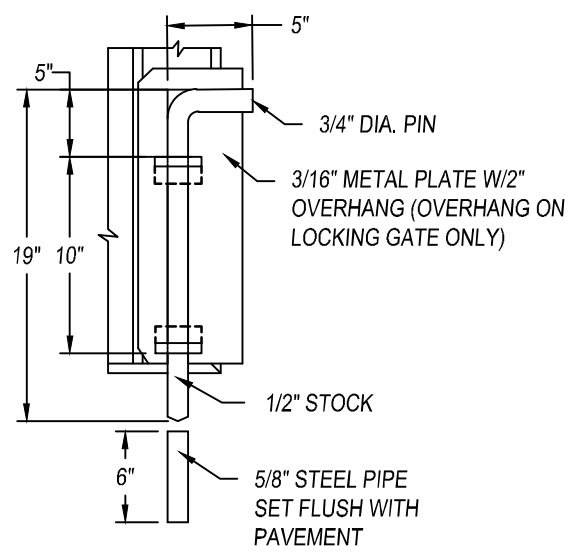

CANE BOLT DETAIL

NOTES:

1. CUT CORNER BLOCK ENDS AND CENTER WEB TO FORM A CONT. BOND BEAM.
2. LOCATION OF THE BIN ENCLOSURE TO BE APPROVED BY THE CITY.
3. DOOR COLOR 1C1 ANTIQUE BISQUE #6-8534.
4. SECONDARY CANE BOLT RETAINER TO BE PLACED FOR EACH GATE SUCH THAT IS HELD IN A POSITION 90 DEGREES TO THE CLOSED POSITION.



CITY COUNCIL APPROVAL: 01/24/2023
 APPROVED BY CITY ENGINEER
 APPROVED BY PUBLIC WORKS DIRECTOR

TRASH ENCLOSURE GATE DETAIL
PUBLIC IMPROVEMENT STANDARDS

M-4		
REVISIONS		
NAME	BY	DATE

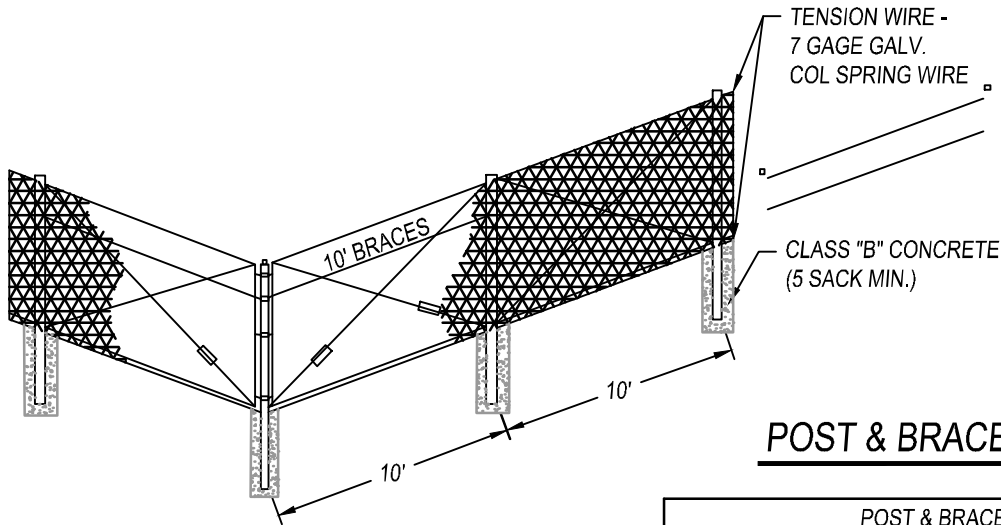

POST & BRACE REQUIREMENTS

POST & BRACE REQUIREMENTS			
LOCATION	TYPE	MIN. SIZE	MIN. WT. (LB/LF)
END & CORNER POST	PIPE	2.351 O.D.	3.10
LINE POSTS	PIPE	1.869 O.D.	2.31
BRACES	PIPE	1.630 O.D.	1.93
GATE POSTS	PIPE	3.960 O.D.	8.65

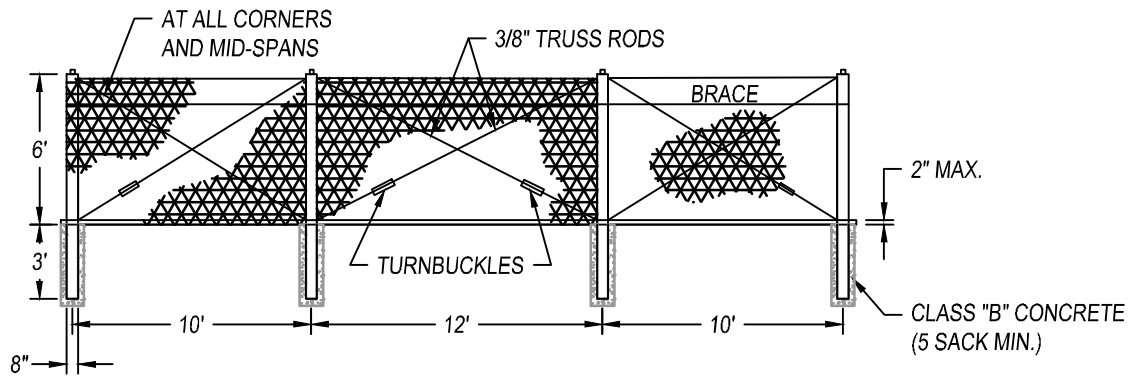

NOTES:

- GATE FRAME SHALL BE CONSTRUCTED OF NOT LESS THAN 1-1/2" GALVANIZED PIPE AND SHALL BE CROSS TRUSSED WITH 3/8" ADJUSTABLE TRUSS RODS. THE CORNER OF GATE FRAMES SHALL BE FASTENED TOGETHER WITH A MALLEABLE IRON FITTING.
- THE GATE SHALL BE HUNG BY AT LEAST 2 STEEL OR MALLEABLE IRON HINGES NOT LESS THAN 3" IN WIDTH, AND A MALLEABLE CATCH AND LOCKING ATTACHMENT.
- ALL POSTS SHALL BE MINIMUM OF 9' LONG.
- ALL FENCES SHALL HAVE REQUIRED SAFETY SIGNS INSTALLED TO CITY STANDARDS (EVERY 100').
- END, CORNER, AND GATE POSTS SHALL BE BRACED TO THE NEAREST LINE POST WITH GALVANIZED DIAGONAL OR HORIZONTAL BRACES USED AS COMPRESSION MEMBERS AND GALVANIZED 3/8" STEEL TRUSS RODS WITH TURNBUCKLES USED AS TENSION MEMBERS.
- LINE POSTS SHALL BE SPACED AT NOT MORE THAN 10-FOOT INTERVALS, MEASURED FROM CENTER TO CENTER OF POSTS.
- POST TOPS, EXTENSION ARMS, STRETCHER BARS AND OTHER REQUIRED FITTING AND HARDWARE SHALL BE STEEL OR MALLEABLE IRON OR WROUGHT IRON AND SHALL BE GALVANIZED.
- WIRE USED IN THE MANUFACTURE OF THE FABRIC SHALL BE 11-GAGE FOR ALL FENCE 84" OR LESS IN HEIGHT, AND SHALL BE WOVEN INTO APPROXIMATE 2" MESH, PVC COATED, AND COLOR SPECIFIED.



CITY COUNCIL APPROVAL: 01/24/2023

APPROVED BY CITY ENGINEER

APPROVED BY PUBLIC WORKS DIRECTOR

CHAIN LINK FENCE DETAIL

PUBLIC IMPROVEMENT STANDARDS

M-5

REVISIONS

NAME BY DATE

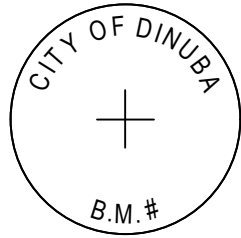

TOP



LOCATE MONUMENT AT THE
END OF RADIUS AS SHOWN



BENCHMARK LOCATION

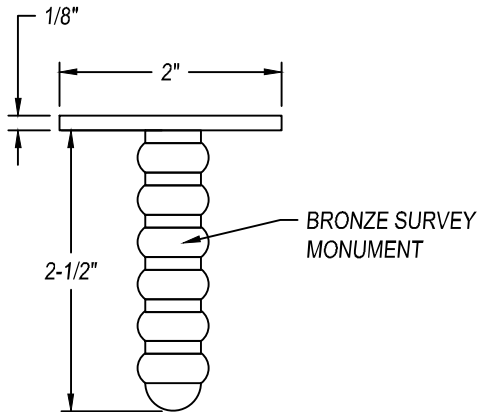

SURVEY MONUMENT

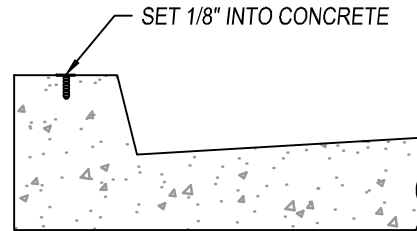

STANDARD CURB & GUTTER

NOTES:

1. LOCATE BENCHMARKS AT THE NORTHEAST CORNER OF INTERSECTIONS-APPROVED BY THE CITY.
2. COMPLETE NOTES SHOWING LOCATIONS, ELEVATIONS, AND CLOSURES SHALL BE FILED WITH THE CITY.
3. ELEVATIONS SHALL BE BASED ON DATUM USED ON U.S.C., G.S., AND CITY RECORD BENCHMARK NUMBERS SHALL BE STAMPED WITH DIES ON TOP.



CITY COUNCIL APPROVAL: 01/24/2023

[Signature]
APPROVED BY CITY ENGINEER

[Signature]
APPROVED BY PUBLIC WORKS DIRECTOR

ELEVATION BENCHMARK DETAILS

PUBLIC IMPROVEMENT STANDARDS

M-6

REVISIONS

NAME	BY	DATE

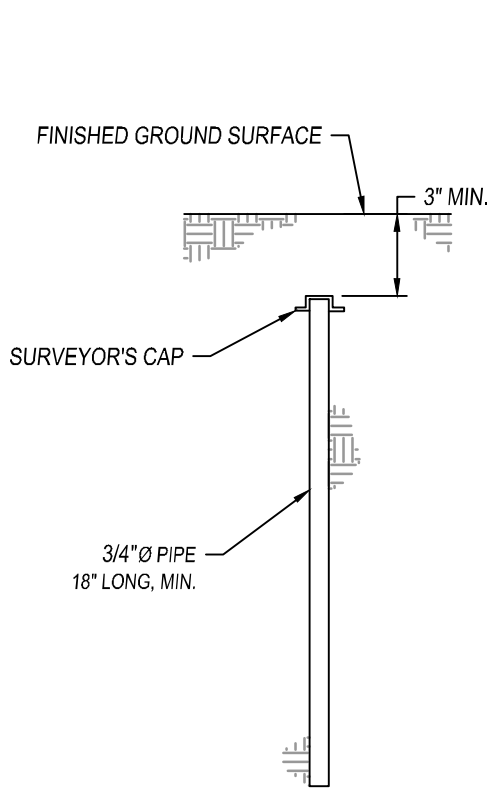

TYPE A
LOT CORNERS

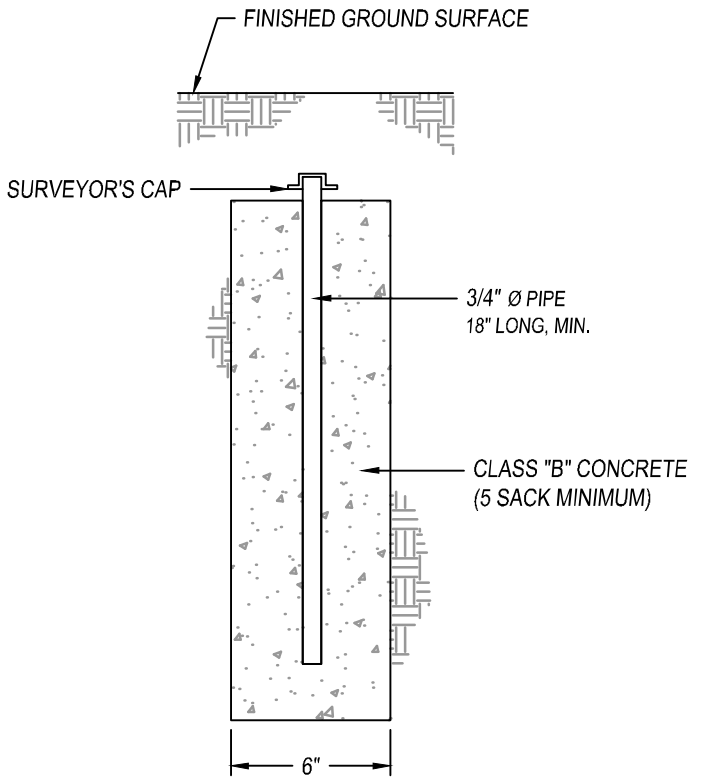

TYPE B
SUBDIVISION CORNERS

NOTES:

1. STATE LAW REQUIRES ALL CORNERS TO BE TAGGED WITH SURVEYOR'S NUMBER.
2. ALL SUBDIVISION LOT CORNERS SHALL REQUIRE TYPE A MONUMENTS.
3. REGULAR SHAPED SUBDIVISIONS SHALL REQUIRE TYPE B MONUMENTS AT ALL CORNERS. IRREGULAR SHAPED SUBDIVISION SHALL HAVE ALL ANGLE AND CURVE POINTS MARKED WITH TYPE B MONUMENTS.



CITY COUNCIL APPROVAL: 01/24/2023

[Signature]
APPROVED BY CITY ENGINEER

[Signature]
APPROVED BY PUBLIC WORKS DIRECTOR

PROPERTY MONUMENT DETAILS

PUBLIC IMPROVEMENT STANDARDS

M-7

REVISIONS

NAME	BY	DATE

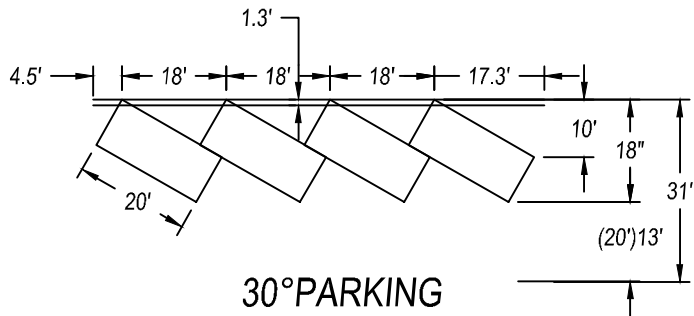

30° PARKING

NOTE: () 2 LANE WIDTH

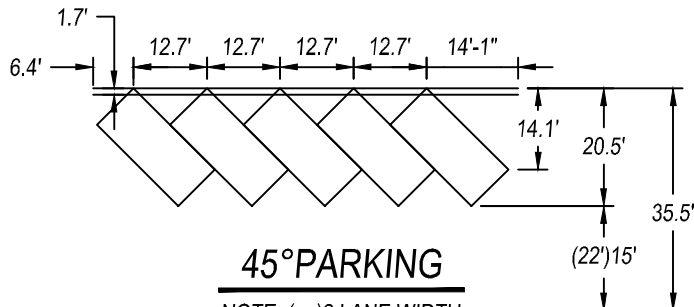

45° PARKING

NOTE: () 2 LANE WIDTH

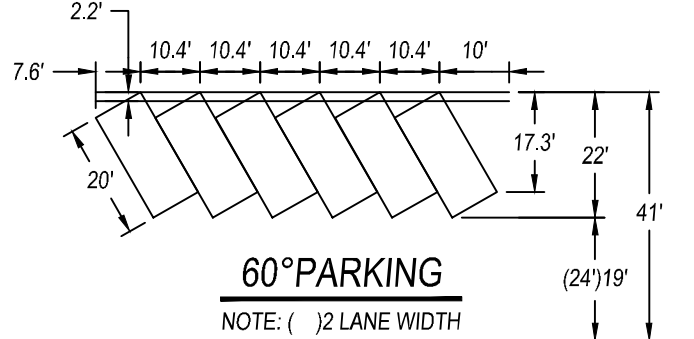

60° PARKING

NOTE: () 2 LANE WIDTH

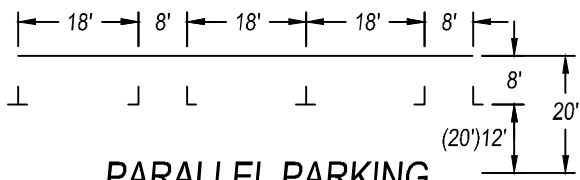

PARALLEL PARKING

NOTE: () 2 LANE WIDTH

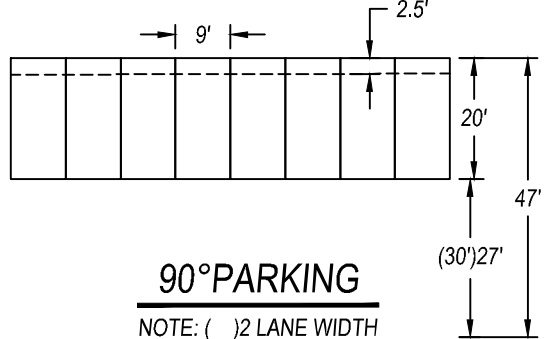

90° PARKING

NOTE: () 2 LANE WIDTH

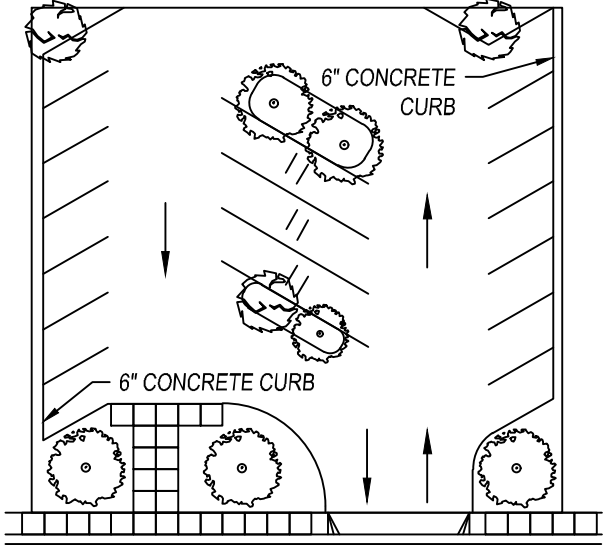

TYPICAL PARKING LOT

DESIGN AND LANDSCAPE

NOTES:

1. LANDSCAPE PARKING AREA - SEE STANDARDS HEREIN.
2. PROVIDE THE REQUIRED NUMBER OF PARKING STALLS AS REQUIRED BY THE CITY OF DINUBA BASED ON ZONING AND LAND USE.
3. INSTALL WHEEL OR BUMPER STOPS TO PREVENT PARKED CARS FROM ENCROACHING OVER SIDEWALKS, ADJOINING PROPERTY, OR CITY RIGHT OF WAY.
4. PROVIDE DRAINAGE PLAN DETAILS PRIOR TO APPROVAL.
5. AISLE WAY WHICH PROVIDES DIRECT ACCESS TO PARKING STALLS SHALL BE ONE-WAY EXCEPT FOR PARKING WHICH IS PARALLEL OR PERPENDICULAR TO IT.
6. PAVING OF LOTS SHALL STOP AT PROPERTY LINE AND NOT ENCROACH ON CITY RIGHT OF WAY.
7. SINGLE SPACE SHALL BE 14' WIDE (9' PARKING - 5' LOADING)
8. ALL STALLS SHALL INCLUDE SIGNAGE AS REQUIRE BY CITY, STATE, AND FEDERAL REGULATIONS.
9. PARKING LOTS SHALL COMPLY WITH THE LATEST EDITION OF THE CALIFORNIA BUILDING CODE.



CITY COUNCIL APPROVAL: 01/24/2023
 APPROVED BY CITY ENGINEER
 APPROVED BY PUBLIC WORKS DIRECTOR

**TYPICAL PARKING LOT
 DESIGN & LANDSCAPE
 PUBLIC IMPROVEMENT STANDARDS**

M-8		
REVISIONS		
NAME	BY	DATE

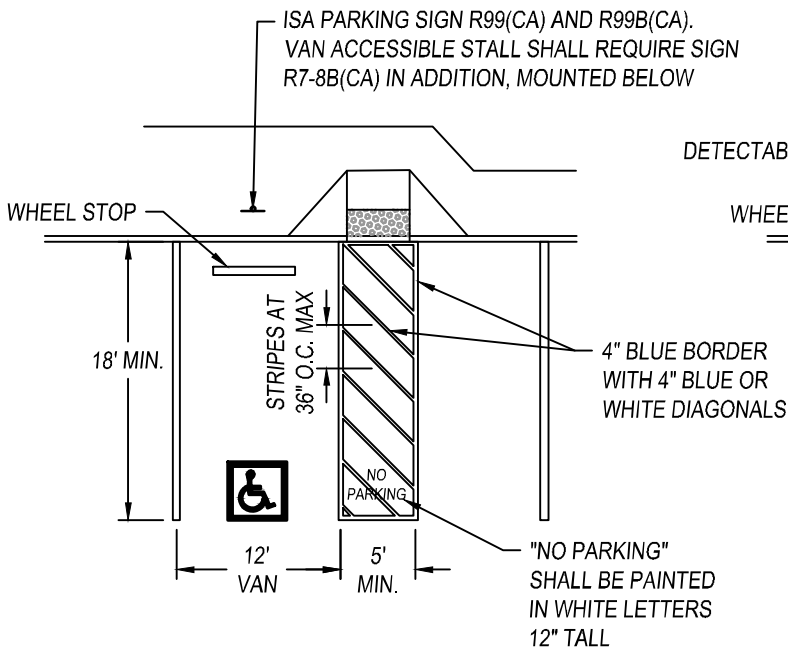

SINGLE PARKING STALLS

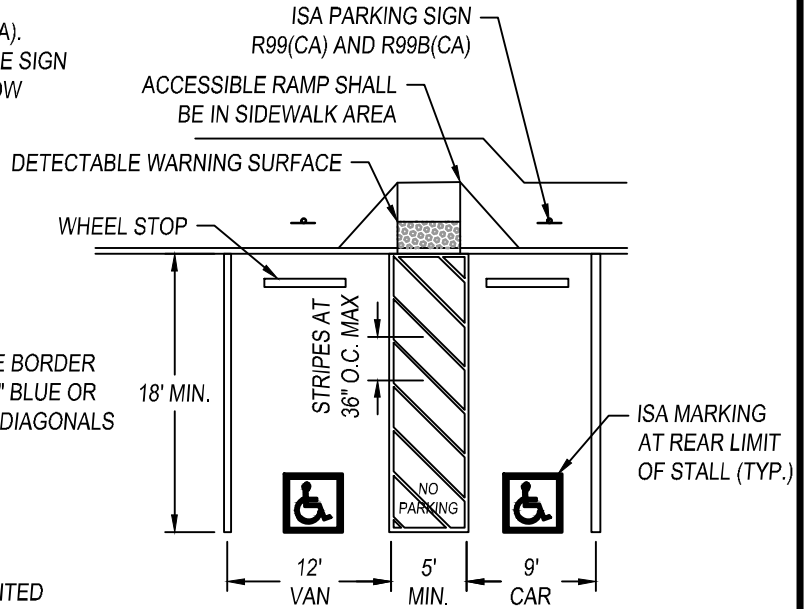

DOUBLE PARKING STALLS

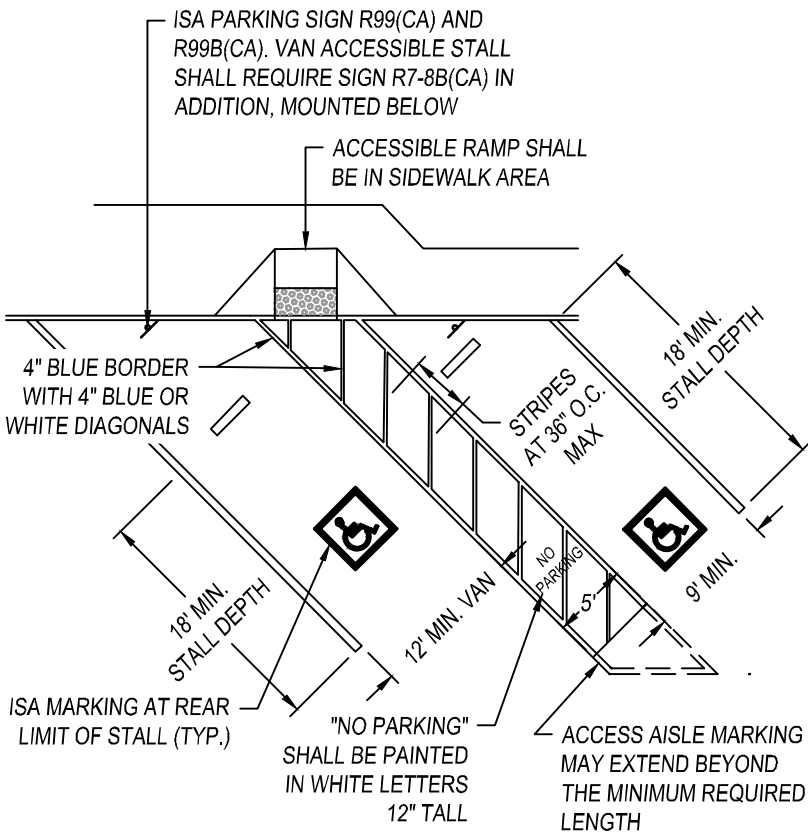

DIAGONAL PARKING STALLS

NOTES:

1. ACCESS AISLE SHALL SERVE THE FULL DEPTH OF EACH ACCESSIBLE PARKING SPACE.
2. HATCHED LINES SHALL BE A COLOR CONTRASTING WITH THAT OF THE AISLE SURFACE, PREFERABLY BLUE OR WHITE.
3. ACCESS AISLE SHALL BE ON THE PASSENGER SIDE OF VAN PARKING SPACES. ACCESS AISLES ARE PERMITTED ON EITHER SIDE OF CAR PARKING SPACES. ACCESS AISLES SHALL EXTEND THE FULL REQUIRED LENGTH OF THE PARKING SPACES THEY SERVE. ACCESS AISLES SHALL ADJOIN AN ACCESSIBLE ROUTE.
4. PARKING SPACES AND ACCESS AISLES SHALL BE DESIGNED SO THAT CARS AND VANS, WHEN PARKING, CANNOT OBSTRUCT THE REQUIRED CLEAR WIDTH OF ADJACENT ACCESSIBLE ROUTES.
5. SIGNS SHALL BE PERMANENTLY POSTED EITHER IMMEDIATELY ADJACENT TO THE PARKING SPACE OR WITHIN THE PROJECTED PARKING SPACE WIDTH AT THE HEAD END OF THE PARKING SPACE. SIGNS MAY ALSO BE PERMANENTLY POSTED ON A WALL AT THE INTERIOR END OF THE PARKING SPACE.
6. ACCESS AISLES OUTLINED IN BLUE WITH DIAGONAL HATCH MARKINGS AT 36" MAX. O.C. IN EITHER BLUE OR WHITE.
7. PARKING SPACES AND ACCESS AISLES SERVING THEM SHALL HAVE A 1:48 MAXIMUM SLOPE IN ALL DIRECTIONS.
8. FOR ANGLED PARKING THE ACCESS AISLE SHALL SERVE THE FULL DEPTH FOR EACH PARKING SPACE THAT IT SERVES. RELOCATE THE CURB RAMP OUTSIDE OF THE ACCESS AISLE, AND REVIDE DETAIL.



CITY COUNCIL APPROVAL: 01/24/2023

APPROVED BY CITY ENGINEER

APPROVED BY PUBLIC WORKS DIRECTOR

ACCESSIBLE PARKING

PUBLIC IMPROVEMENT STANDARDS

M-9

REVISIONS

NAME	BY	DATE

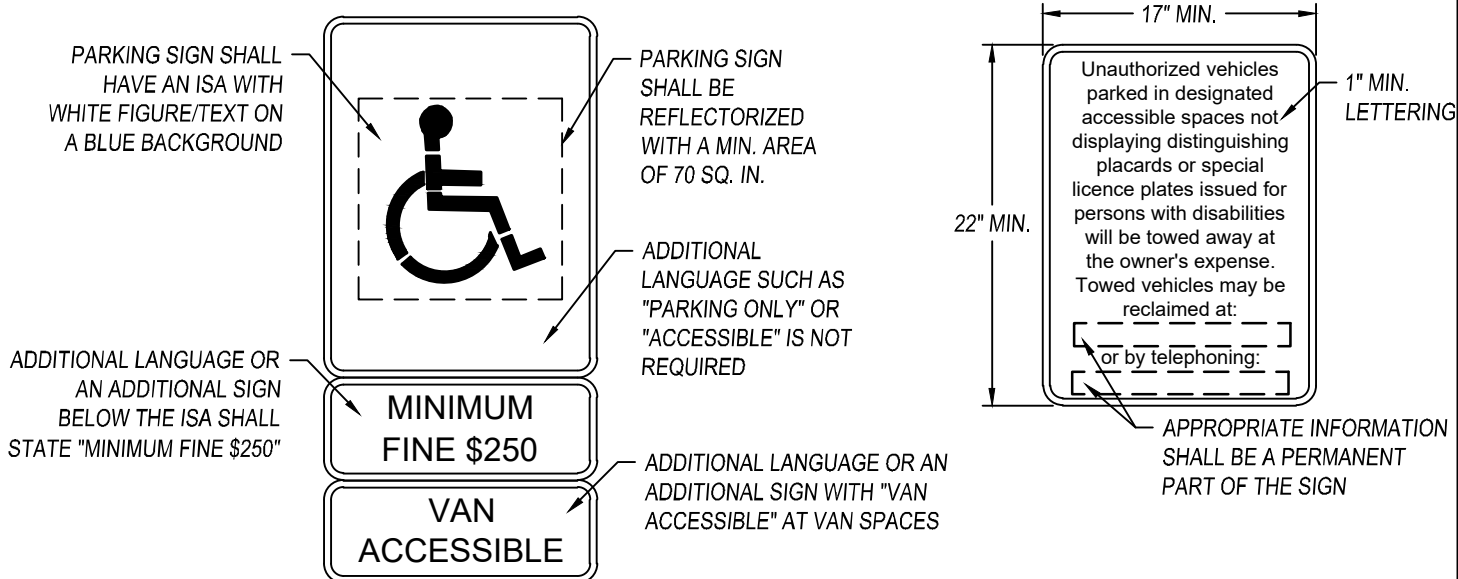

ACCESSIBLE PARKING SPACE SIGNS

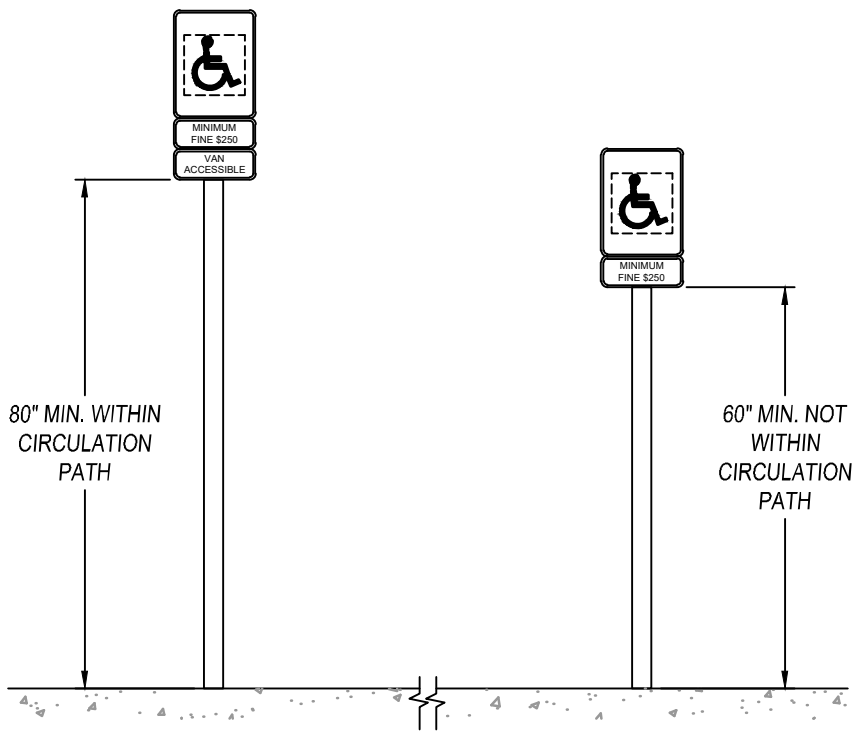

ACCESSIBLE PARKING SIGN LOCATION

NOTES:

1. THE NO PARKING SIGN (OPTIONAL) SHALL BE POSTED EITHER: IN A CONSPICUOUS PLACE AT EACH ENTRANCE TO AN OFF-STREET PARKING FACILITY OR IMMEDIATELY ADJACENT TO ON-SITE ACCESSIBLE PARKING AND VISIBLE FROM EACH PARKING SPACE.
2. THE COLOR BLUE SHALL APPROXIMATE COLOR NO. 15090 IN FEDERAL STANDARD 595C.



CITY COUNCIL APPROVAL: 01/24/2023

[Signature]
APPROVED BY CITY ENGINEER

[Signature]
APPROVED BY PUBLIC WORKS DIRECTOR

ACCESSIBLE PARKING SIGN

PUBLIC IMPROVEMENT STANDARDS

M-10

REVISIONS

NAME	BY	DATE

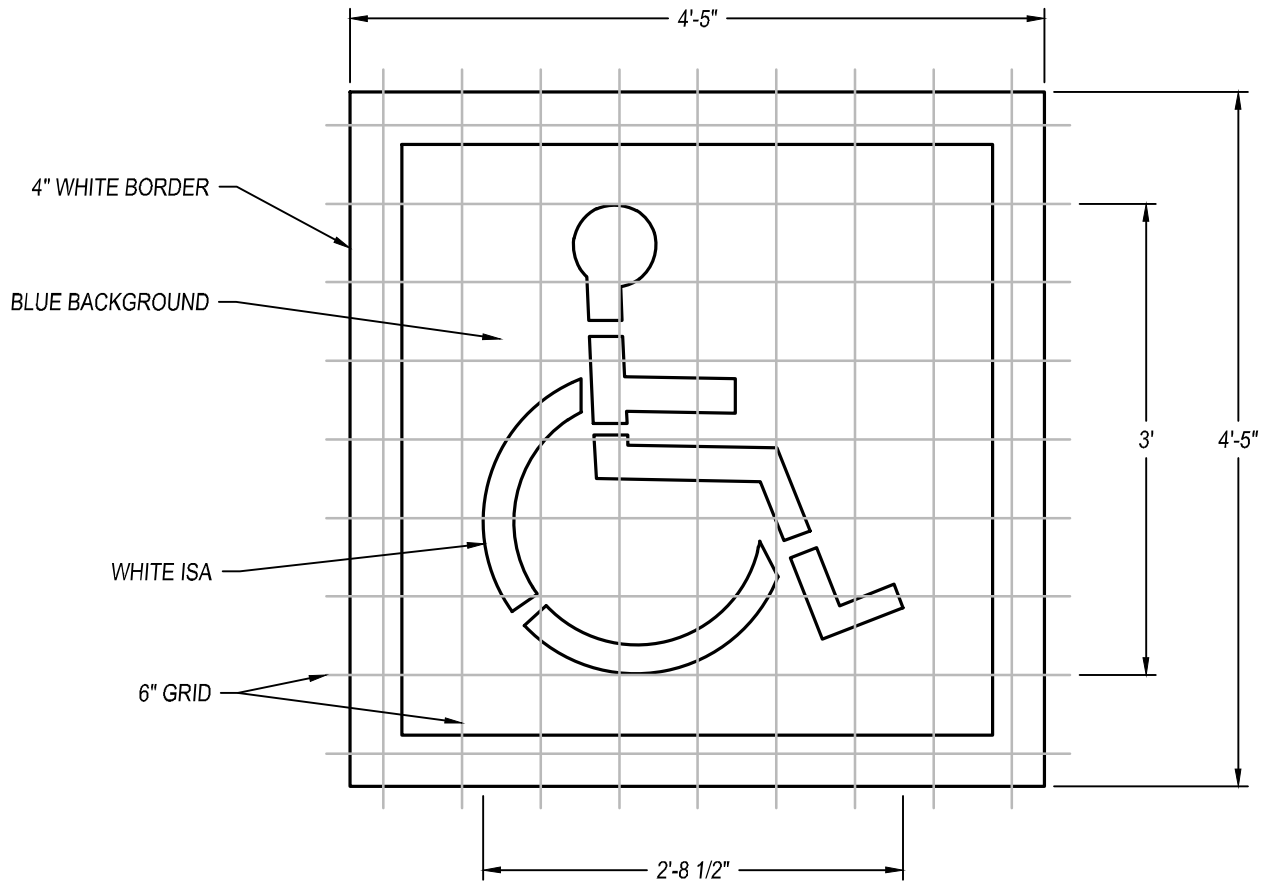

ISA MARKING FOR ACCESSIBLE

PARKING SPACE OR STALL

TOTAL NUMBER OF PARKING SPACES OR STALLS	MINIMUM NUMBER OF DISABLED ACCESSIBLE PARKING SPACES OR STALLS
1-25	1
26-50	2
51-75	3
76-100	4
101-150	5
151-200	6
201-300	7
301-400	8
401-500	9
501-1000	2 PERCENT OF TOTAL
GREATER THAN 1001	20 PLUS 1 FOR EACH 100 OR FRACTION THEREOF OVER 1000



CITY COUNCIL APPROVAL: 01/24/2023
 APPROVED BY CITY ENGINEER
 APPROVED BY PUBLIC WORKS DIRECTOR

**INTERNATIONAL SYMBOL OF
 ACCESSIBILITY (ISA) INSTALLATION
 PUBLIC IMPROVEMENT STANDARDS**

M-11		
REVISIONS		
NAME	BY	DATE

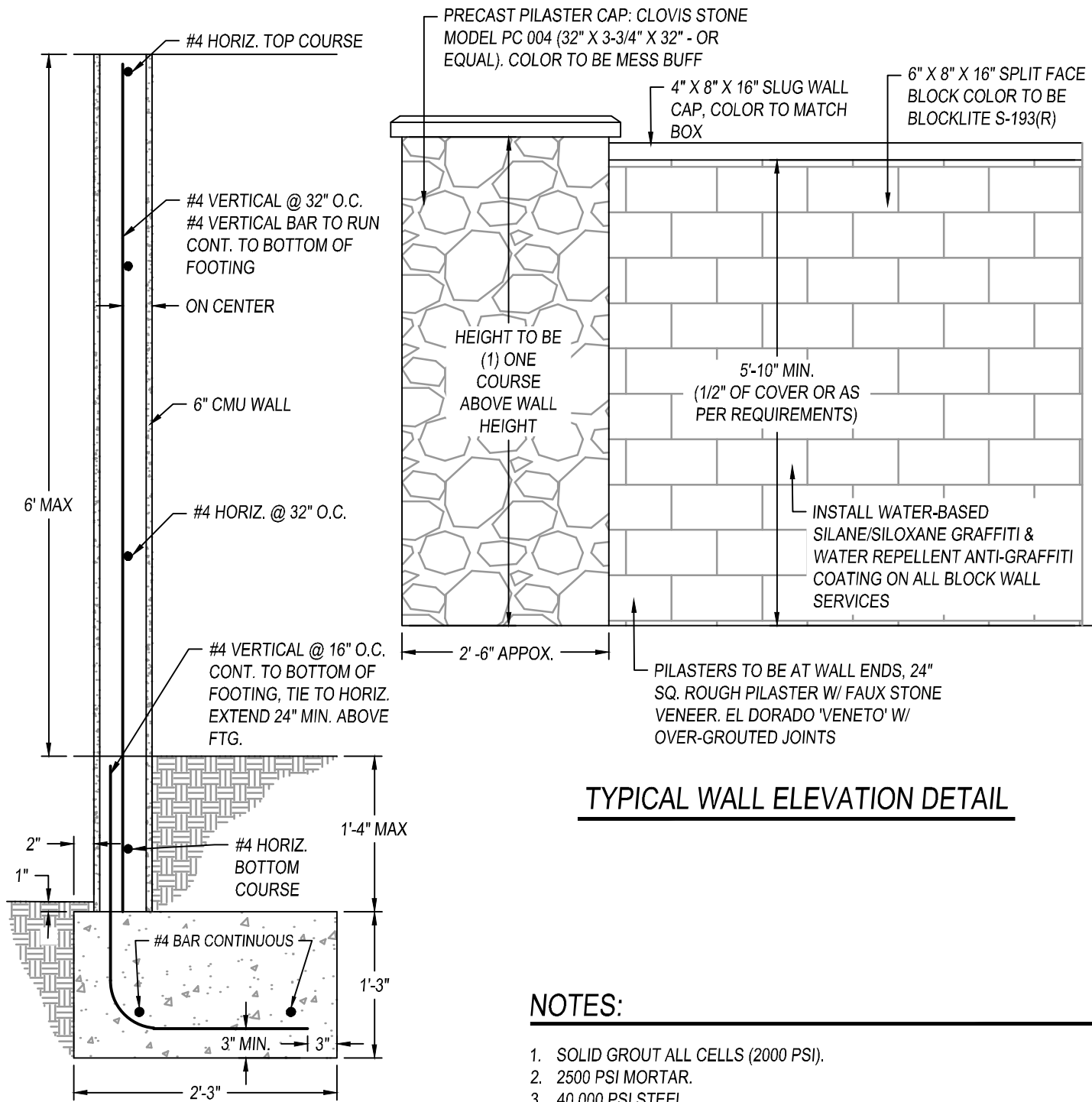

TYPICAL WALL ELEVATION DETAIL

NOTES:

1. SOLID GROUT ALL CELLS (2000 PSI).
2. 2500 PSI MORTAR.
3. 40,000 PSI STEEL.
4. COMPACT TO 90% UNDER FOOTING.
5. DO NOT MORTAR BETWEEN EVERY OTHER C.M.U TO ALLOW FOR MOISTURE TO DRAIN FROM RETAINED SOIL OPENING @ 32" O.C. OF BOTTOM COURSE.
6. 2500 PSI CONCRETE.
7. RETAINING BLOCK WALL WILL REQUIRE A SEPARATE BUILDING PERMIT ISSUED BY THE CITY.



CITY COUNCIL APPROVAL: 01/24/2023
 APPROVED BY CITY ENGINEER
 APPROVED BY PUBLIC WORKS DIRECTOR

MASONRY BLOCK WALL/FENCE
PUBLIC IMPROVEMENT STANDARDS

M-12		
REVISIONS		
NAME	BY	DATE

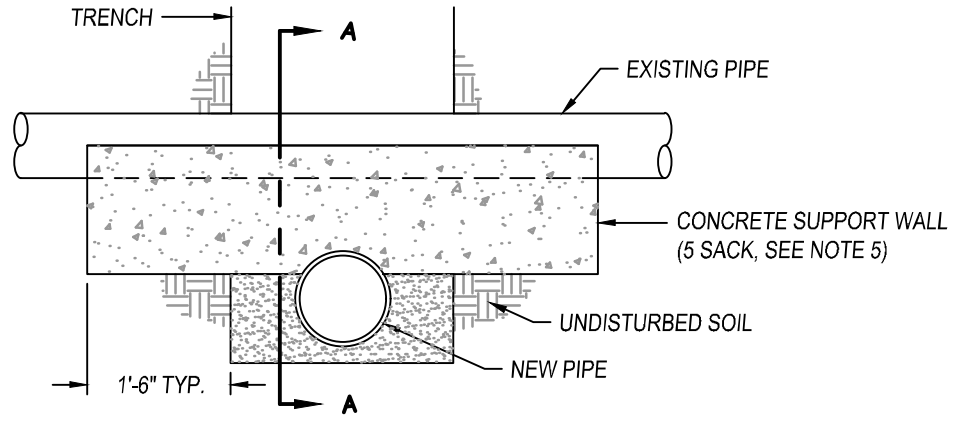

TYPICAL SECTION

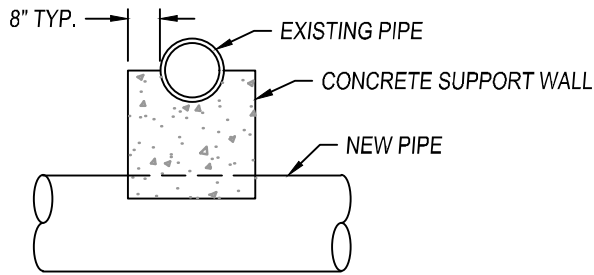

SECTION A-A

NOTES:

1. THIS STANDARD APPLIES WHEN THE PIPE SEPARATION IS LESS THEN A FOOT.
2. THE SUPPORTING WALL SHALL HAVE A FIRM BEARING ON THE SUBGRADE AND AGAINST THE SIDES OF THE EXCAVATION.
3. THE WALL SHALL BE AT LEAST 6" FREE AND CLEAR OF WATER MAINS OR OTHER CONDUITS OR DUCTS.
4. THE WALL THICKNESS SHALL BE EQUAL TO THE O.D. OF THE PIPE +8".
5. THE EXISTING PIPE SHALL BE ENCASED TO THE SPRINGLINE.
6. VERIFY WITH UTILITY COMPANIES FOR CLEARANCE.



CITY COUNCIL APPROVAL: 01/24/2023
 APPROVED BY CITY ENGINEER
 APPROVED BY PUBLIC WORKS DIRECTOR

PIPE SUPPORTS ACROSS TRENCHES
PUBLIC IMPROVEMENT STANDARDS

M-13		
REVISIONS		
NAME	BY	DATE

SEE CITY STD FOR ASPHALT AND
AGGREGATE BASE DEPTH

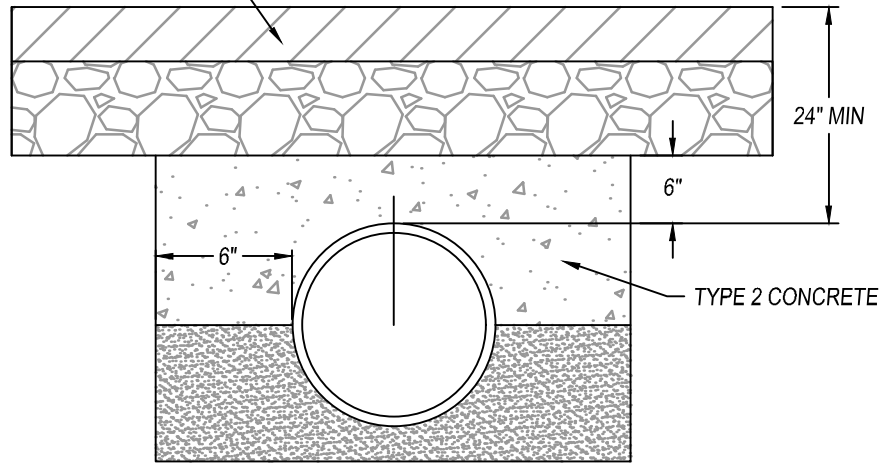

SHALLOW PIPE BACKFILL

NOTES:

1. CONCRETE BACKFILL SHALL BE REQUIRED FOR ALL PIPES WITHIN LESS THEN 24" OF COVER AS OR AS DIRECTED BY THE CITY ENGINEER
2. CONCRETE BACKFILL SHALL BE PLACED IN THE TRENCH AGAINST UNDISTURBED SOIL AND SHALL BE PLACED IN A MANNER THAT WILL PREVENT FLOATING OR SHIFTING OF THE PIPE.



CITY COUNCIL APPROVAL: 01/24/2023

 APPROVED BY CITY ENGINEER

 APPROVED BY PUBLIC WORKS DIRECTOR

SHALLOW PIPE BACKFILL

PUBLIC IMPROVEMENT STANDARDS

M-14

REVISIONS

NAME	BY	DATE

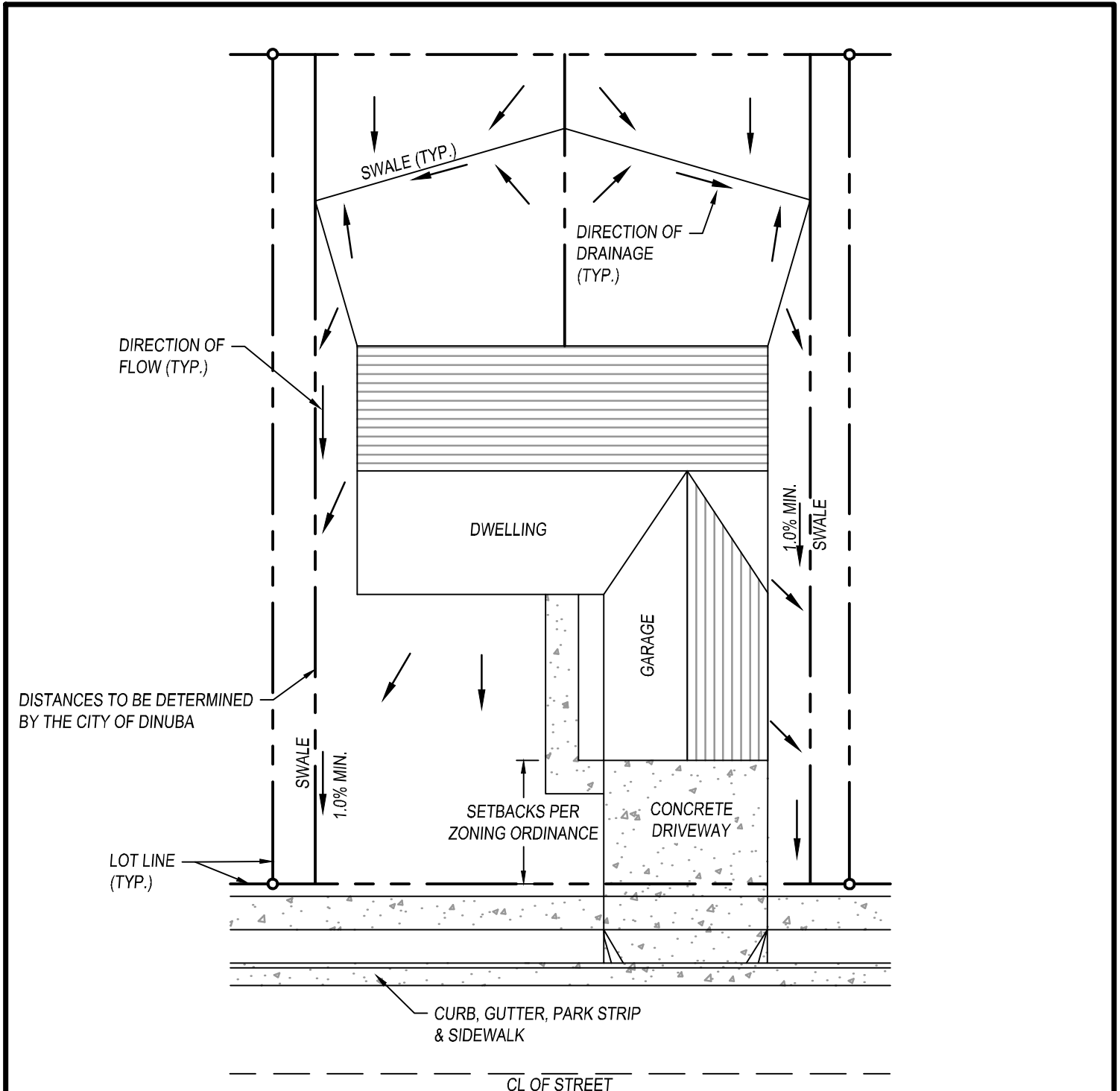

NOTES:

1. LOTS SHALL BE GRADED TO DRAIN TO THE STREETS.
2. FINISH FLOOR ELEVATION SHALL BE A MIN. OF 18" FROM FLOWLINE OF CURB AT LOWEST POINT ALONG PROP. FRONTAGE.
3. MAINTAIN POSITIVE DRAINAGE AWAY FROM DWELLING STRUCTURE, MINIMUM 5' AT 2%.
4. A RETAINING STRUCTURE SHALL BE REQUIRED ALONG ALL SIDE AND BACKYARD PROPERTY LINES WHERE GRADE DIFFERENTIAL EXCEEDS 6", UNLESS APPROVED OTHERWISE BY THE CITY ENGINEER.
5. LANDSCAPING SHALL NOT ALTER LOT DRAINAGE DESIGN.
6. LOT DRAINAGE SHALL FOLLOW THE LATEST EDITION OF THE CBC.

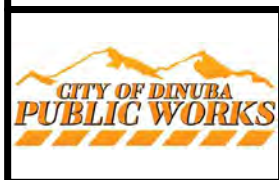

CITY COUNCIL APPROVAL: 01/24/2023

APPROVED BY CITY ENGINEER

APPROVED BY PUBLIC WORKS DIRECTOR

**TYPICAL LOT DRAINAGE WITH
PARK STRIPS SHOWN
PUBLIC IMPROVEMENT STANDARDS**

M-15		
REVISIONS		
NAME	BY	DATE

SA ASSEMBLY TO INCLUDE:

FRONT VIEW

SIDE VIEW

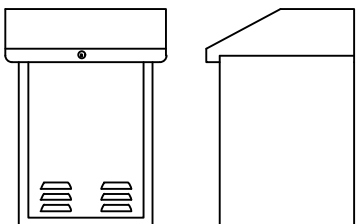

CONTROLLER MODEL AS SPECIFIED

SA ASSEMBLY TO INCLUDE:

- OPTIONS AS SPECIFIED
- TERMINAL STRIPS
- TEMPLATE & BOLTS
- 8' COPPER GROUND ROD
- GROUND ROD CLAMP
- 10' OF GROUND WIRE

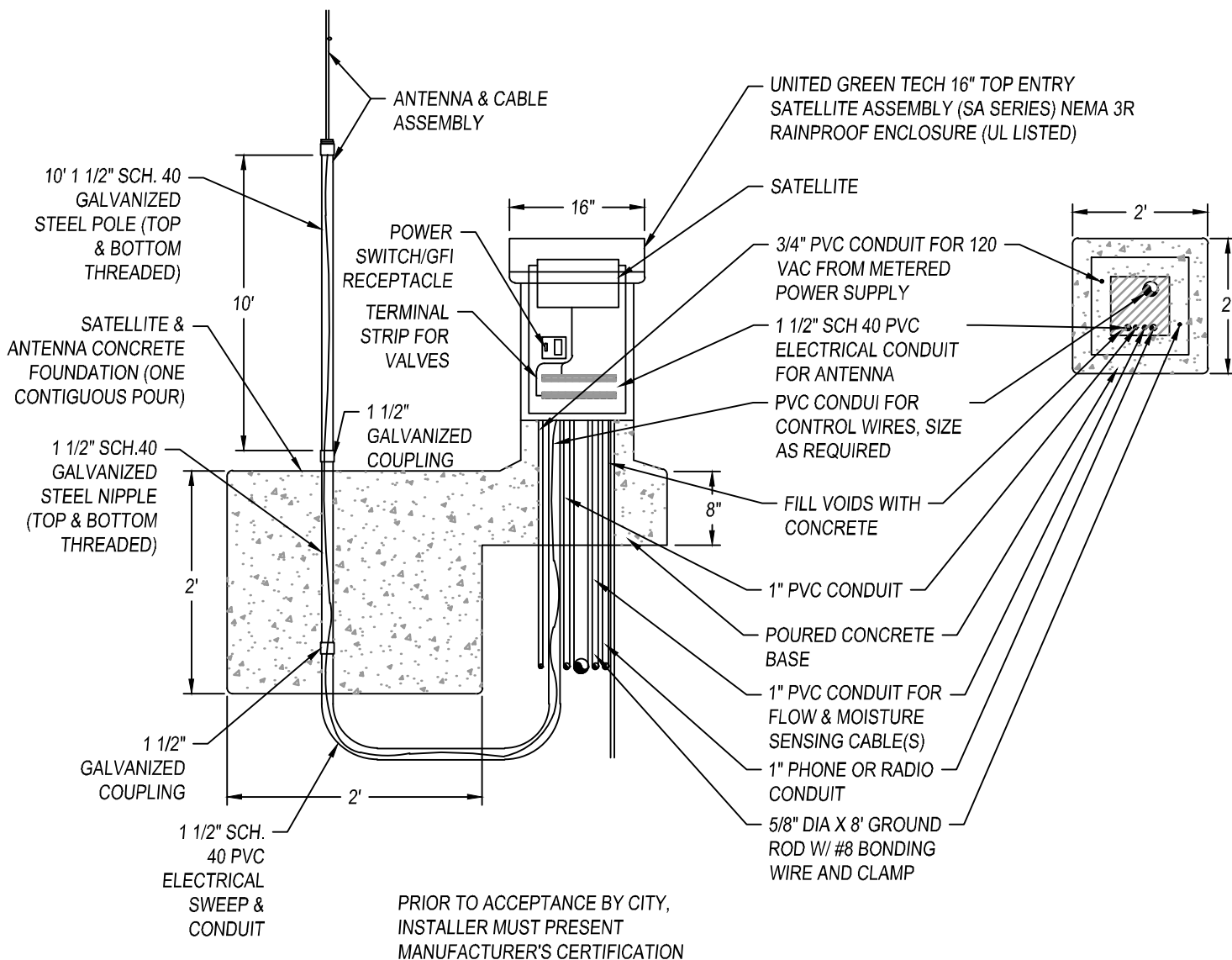

PRIOR TO ACCEPTANCE BY CITY,
INSTALLER MUST PRESENT
MANUFACTURER'S CERTIFICATION

NOTE:

1. FOR USE WITHIN ALL PUBLIC RIGHT-OF-WAY OR PUBLICLY OWNED PROPERTY



CITY COUNCIL APPROVAL: 01/24/2023

[Signature]
APPROVED BY CITY ENGINEER

[Signature]
APPROVED BY PUBLIC WORKS DIRECTOR

SATELLITE ASSEMBLY (CONTROLLER)

PUBLIC IMPROVEMENT STANDARDS

M-16

REVISIONS

NAME	BY	DATE

INTERIOR LOTS

WITH GRADE DIFFERENCE
LESS THEN 2'

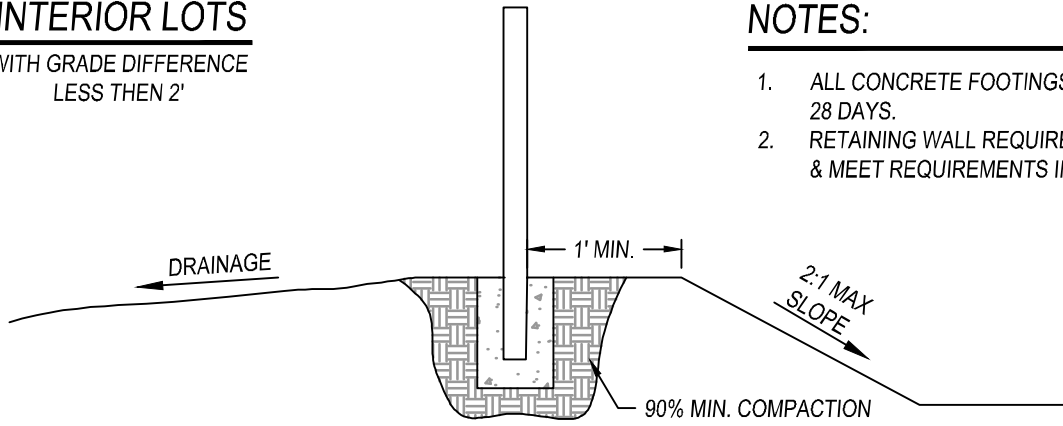

NOTES:

1. ALL CONCRETE FOOTINGS SHALL BE 2500 PSI @ 28 DAYS.
2. RETAINING WALL REQUIRE CITY BUILDING PERMIT, & MEET REQUIREMENTS IF STD. DRAWING M-12

INTERIOR LOTS

WITH GRADE DIFFERENCE
2' OR GREATER.

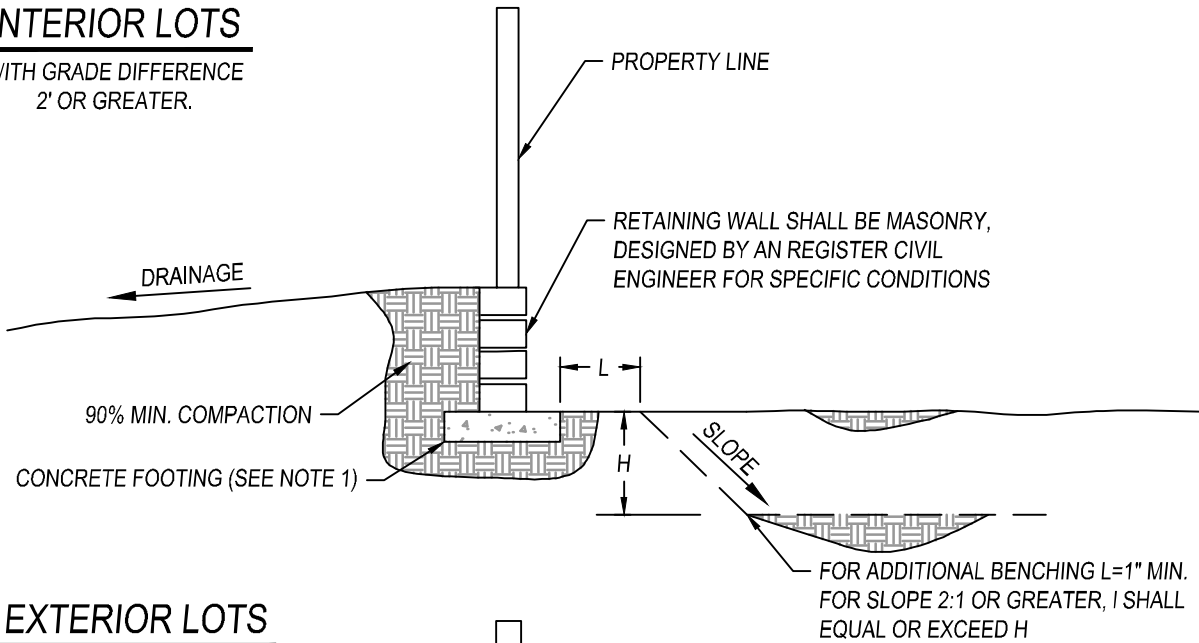

EXTERIOR LOTS

WITH GRADE DIFFERENCE

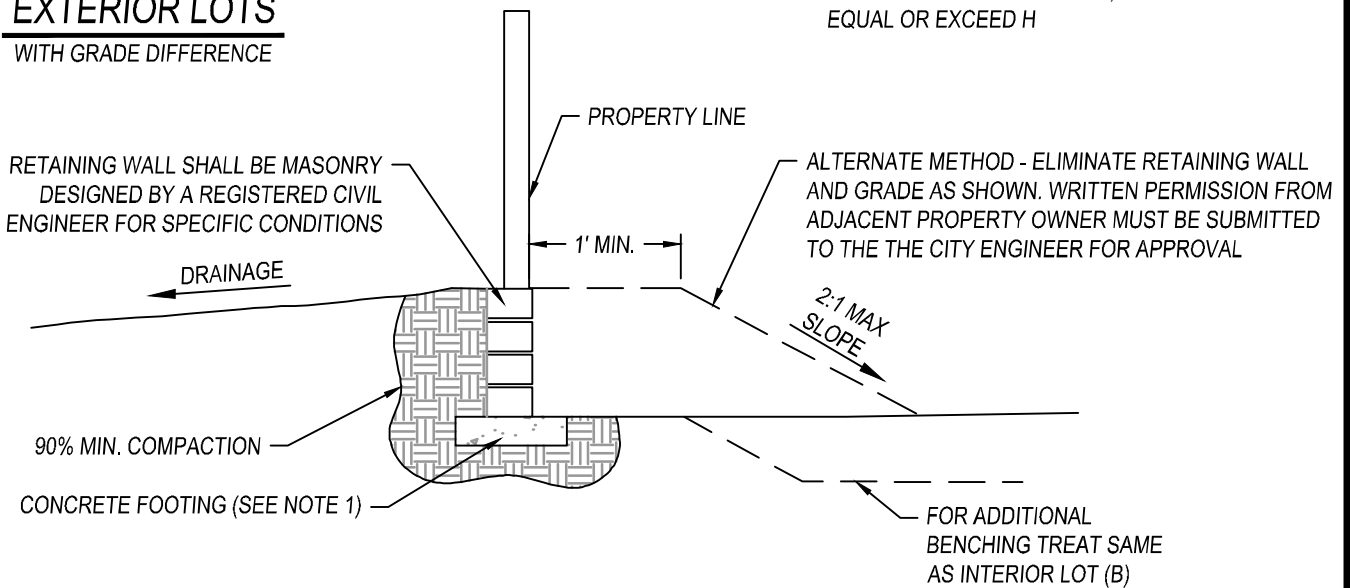

CITY COUNCIL APPROVAL: 01/24/2023

APPROVED BY CITY ENGINEER

APPROVED BY PUBLIC WORKS DIRECTOR

LOT LINE GRADING STANDARD

PUBLIC IMPROVEMENT STANDARDS

M-17

REVISIONS

NAME	BY	DATE

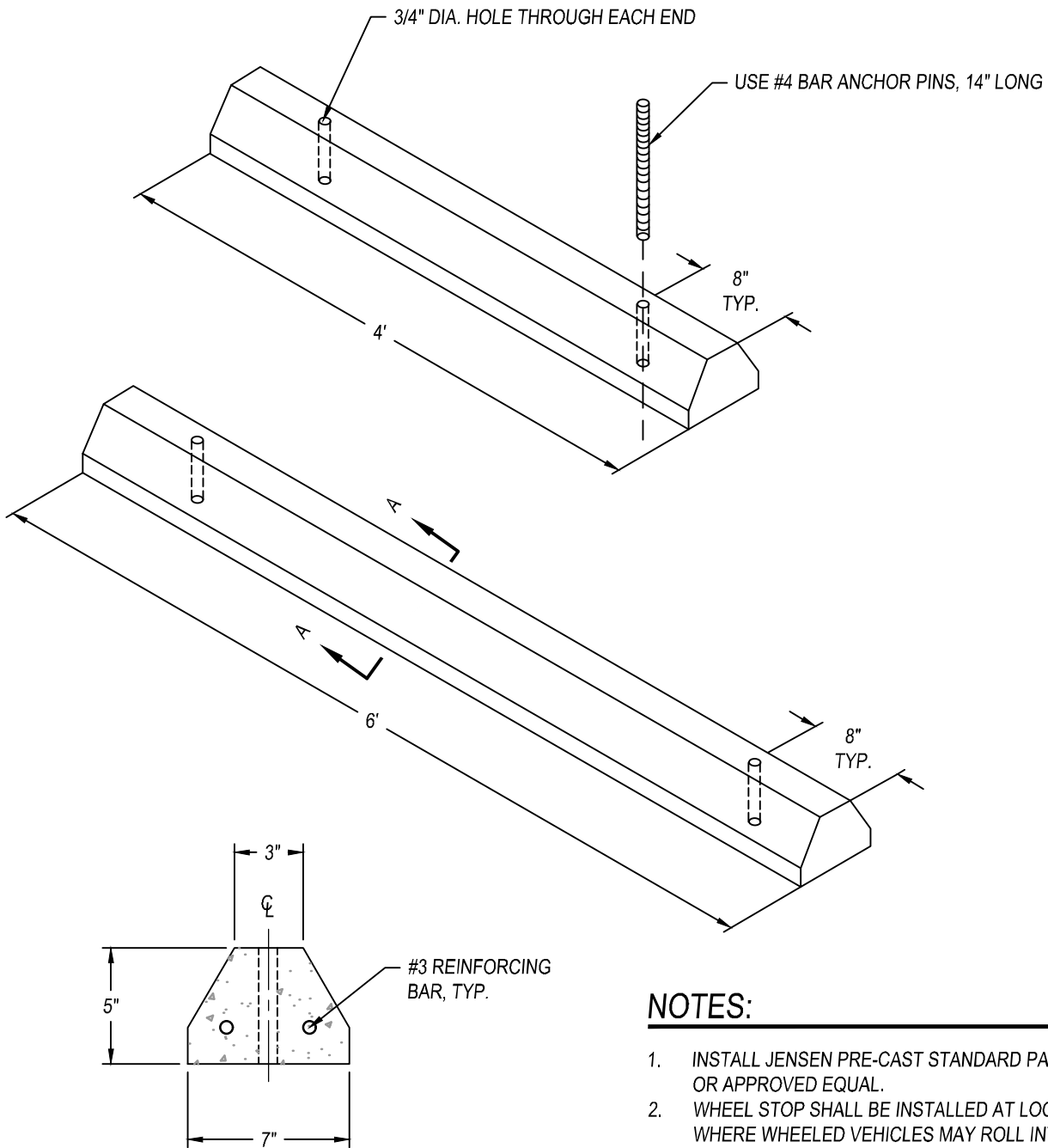

NOTES:

1. INSTALL JENSEN PRE-CAST STANDARD PARKING CURB OR APPROVED EQUAL.
2. WHEEL STOP SHALL BE INSTALLED AT LOCATION WHERE WHEELED VEHICLES MAY ROLL INTO PEDESTRIAN, STRUCTURES, OR HAZARDOUS AREA. WHEEL STOP LOCATION SHALL NOT CREATE A BARRIER FOR PEDESTRIANS.
3. WHEEL STOP SHALL BE SECURELY ATTACHED ONTO AT-GRADE CONCRETE AND AT-GRADE ASPHALT PAVEMENT WITH #4 BAR ANCHOR PINS EMBEDDED IN HOLES CAST INTO WHEEL STOPS.



CITY COUNCIL APPROVAL: 01/24/2023

[Signature]
APPROVED BY CITY ENGINEER

[Signature]
APPROVED BY PUBLIC WORKS DIRECTOR

WHEEL STOP

PUBLIC IMPROVEMENT STANDARDS

M-18

REVISIONS

NAME	BY	DATE

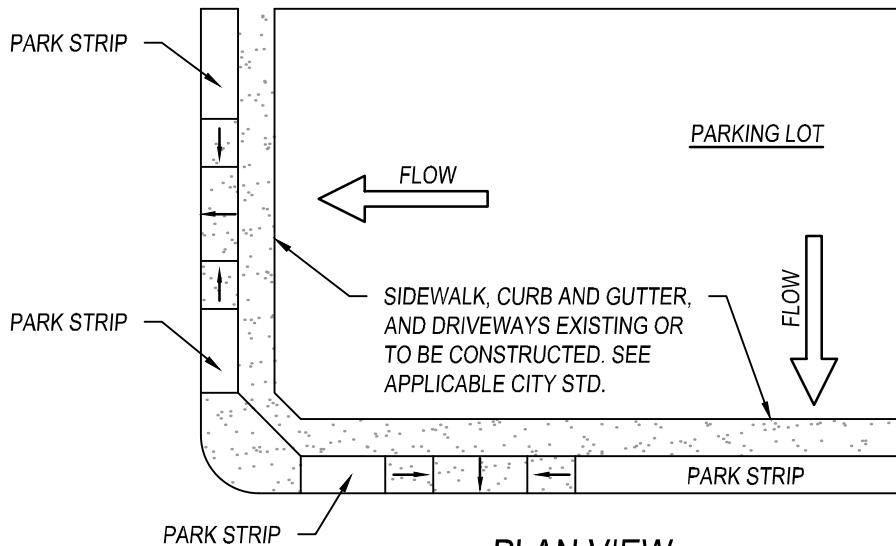

PLAN VIEW

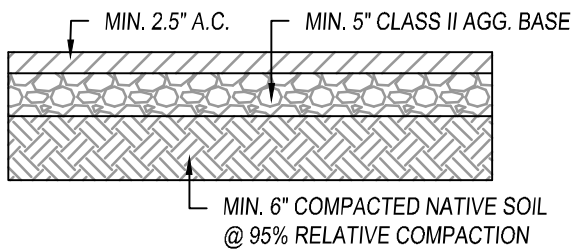

PARKING LOT CROSS-SECTION

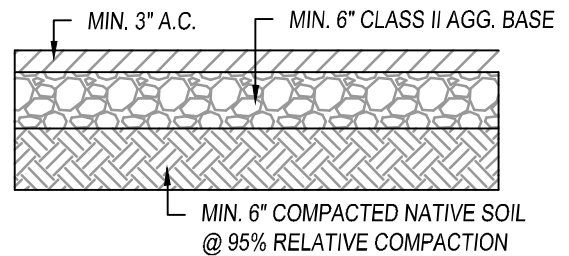

INDUSTRIAL PARKING LOT AND LOADING ZONE CROSS-SECTION

NOTES:

1. A COMPLETE DRAINAGE PLAN AND PARKING STALL LAYOUT SHALL BE SUBMITTED TO THE CITY FOR APPROVAL PRIOR TO ANY CONSTRUCTION.
2. MINIMUM SLOPE SHALL BE 1.5% FOR ASPHALT SURFACE AND 0.25% FOR FLOWLINES.
3. PROVIDE ADEQUATE DRAINAGE THROUGH APPROVED CATCH BASINS AND PIPES TO THE NEAREST STORM DRAIN SYSTEM SURFACE FLOW OVER SIDEWALKS OR LANDSCAPE AREA IS NOT PERMITTED.
4. SURFACE DRAINAGE TO ALLEY MAY BE ALLOWED ONLY BY WRITTEN APPROVAL OF THE CITY OF DINUBA.
5. WEED KILLER SHALL BE APPLIED IN ACCORDANCE WITH MFGRS. RECOMMENDATIONS, TO BASE ROCK PRIOR TO PAVING.
6. THE DESIGN SHALL MAXIMIZE ON-SITE DRAINAGE RETENTION.
7. SURFACE DRAINAGE SHALL BE TO APPROVED LOCATIONS.
8. PAVEMENT STRUCTURAL SECTION SHALL BE DESIGNED BY A REGISTERED CIVIL ENGINEER BASED UPON THE R-VALUE CALCULATIONS. DETAIL ABOVE ONLY PROVIDE MINIMUM PAVEMENT SECTIONS.
9. PARKING BUMPERS TO BE PLACED SO THAT PARKED CARS WILL NOT ENCROACH ON SIDEWALKS OR PARKWAYS.



CITY COUNCIL APPROVAL: 01/24/2023

 APPROVED BY CITY ENGINEER

 APPROVED BY PUBLIC WORKS DIRECTOR

PARKING LOT PAVEMENT STANDARDS
PUBLIC IMPROVEMENT STANDARDS

P-1		
REVISIONS		
NAME	BY	DATE

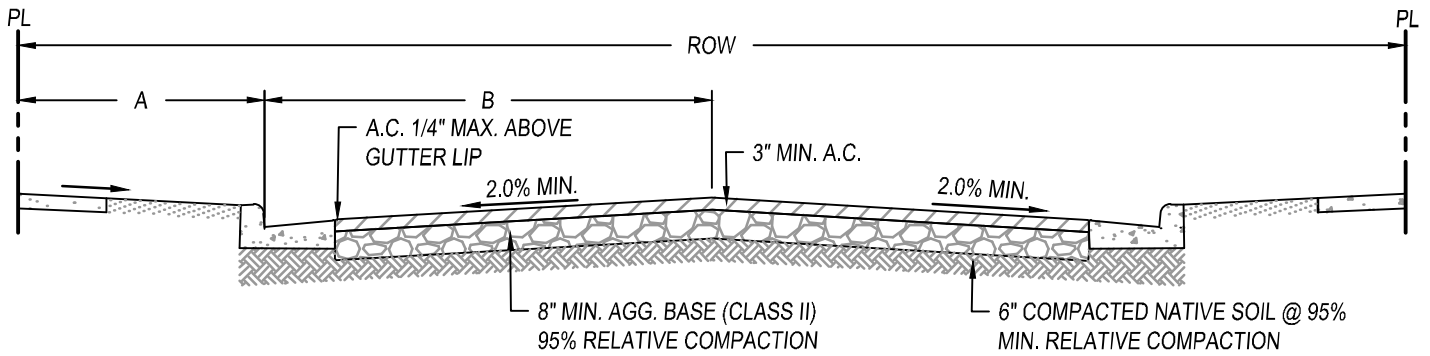

STREET SECTION TABLE			
TYPE OF STREET	ROW	A	B
ARTERIAL STREET (2 TRAVEL LANE)	90'	15'	30'
ARTERIAL STREET (2 TRAVEL LANE)	108'	15'	39'
MAJOR COLLECTOR STREET (2 TRAVEL LANE)	90'	15'	30'
MINOR COLLECTOR STREET	72'	10'	26'
LOCAL COLLECTOR STREET	60'	10'	20'
LOCAL STREET	56'	10'	18'

STREET CROSS-SECTION WITH PLANTER

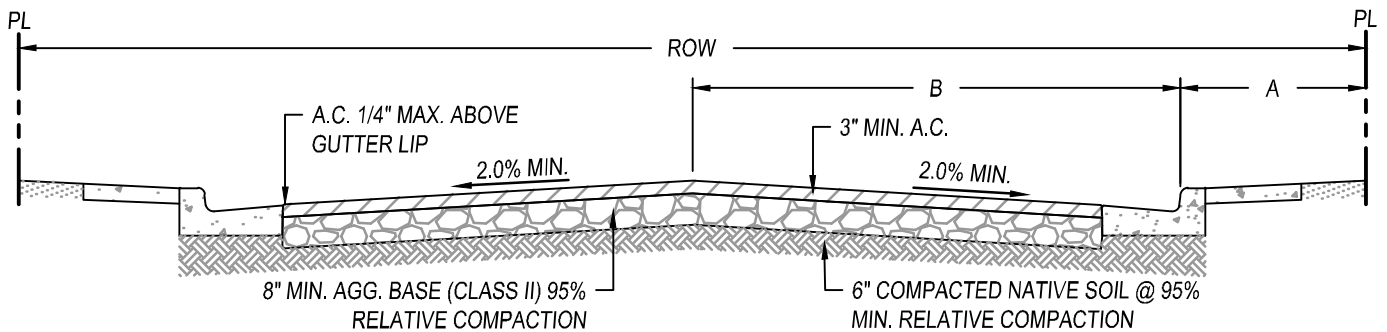

STREET SECTION TABLE			
TYPE OF STREET	ROW	A	B
ARTERIAL STREET (2 TRAVEL LANE)	90'	15'	30'
ARTERIAL STREET (2 TRAVEL LANE)	108'	15'	39'
MAJOR COLLECTOR STREET (2 TRAVEL LANE)	90'	15'	30'
MINOR COLLECTOR STREET	72'	10'	26'
LOCAL COLLECTOR STREET	60'	10'	20'
LOCAL STREET	56'	10'	18'

STREET CROSS-SECTION WITHOUT PLANTER

NOTES:

1. ASPHALT AND AGGREGATE BASE ARE SHOWN AT MIN. REQUIRED DEPTHS, SUBJECT TO R-VALUE AND TRAFFIC INDEX BASED CALCULATIONS BY A REGISTERED CIVIL ENGINEER.
2. RECYCLED AGGREGATE BASE IS ALLOWED IF CERTIFIED PER CALTRANS STDS. & APPROVED BY CITY STAFF.
3. PROVIDE A CALTRANS CERTIFICATE OF COMPLIANCE FROM SUPPLIER FOR ALL MATERIALS.
4. R-VALUE AND PAVEMENT CALCULATIONS SHALL BE SUBMITTED TO THE CITY OF DINUBA BY GEOTECHNICAL ENGINEER.



CITY COUNCIL APPROVAL: 01/24/2023

[Signature]
APPROVED BY CITY ENGINEER

[Signature]
APPROVED BY PUBLIC WORKS DIRECTOR

STREET CROSS-SECTION

PUBLIC IMPROVEMENT STANDARDS

P-2

REVISIONS

NAME	BY	DATE

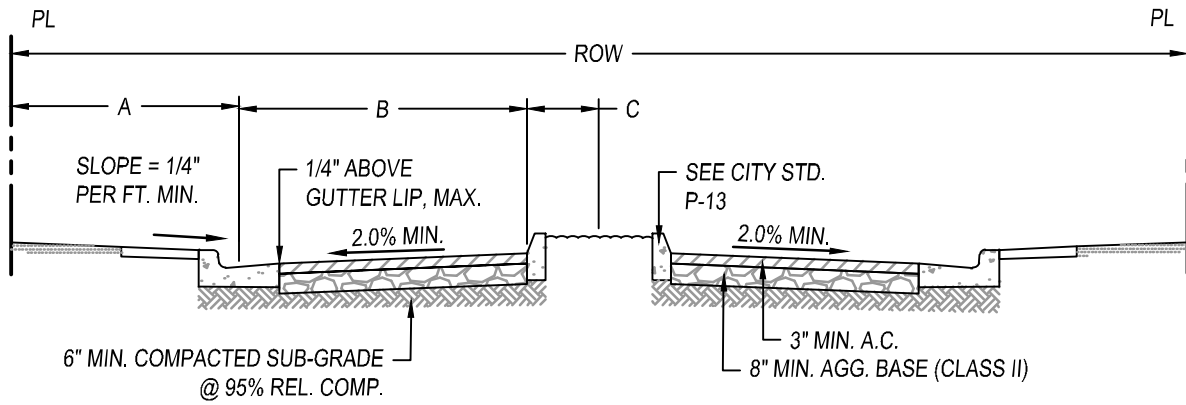

STREETS WITH MEDIAN WITHOUT PARK STRIP				
TYPE OF STREET	ROW	A	B	C
MAJOR ARTERIAL STREET (2 TRAVEL LANE)	126'	15'	39'	9'
MINOR COLLECTOR STREET (2 TRAVEL LANE)	96'	15'	26'	7'

STREET CROSS-SECTION WITHOUT PLANTER

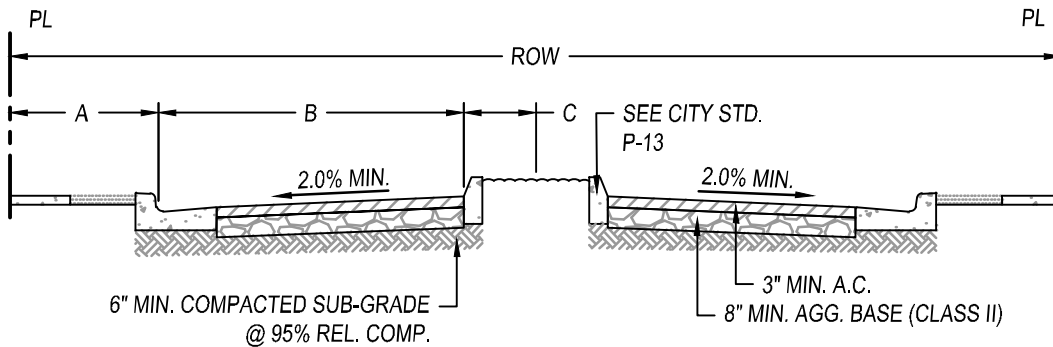

STREETS WITH MEDIAN WITH PARK STRIP				
TYPE OF STREET	ROW	A	B	C
MAJOR ARTERIAL STREET	126'	15'	39'	9'
MINOR COLLECTOR STREET	96'	15'	26'	7'

STREET CROSS-SECTION WITH PLANTER

NOTES:

1. ASPHALT AND AGGREGATE BASE ARE SHOWN AT MINIMUM REQUIRED DEPTHS, SUBJECT TO R-VALUE BASED CALCULATIONS BY A REGISTERED CIVIL ENGINEER.
2. RECYCLED AGGREGATE BASE IS ALLOWED IF CERTIFIED PER CALTRANS STDS, & APPROVED BY CITY STAFF.
3. PROVIDE A CALTRANS CERTIFIED OF COMPLIANCE FROM SUPPLIER FOR ALL MATERIALS.
4. REFER TO CITY STD. FOR SIDEWALK, CURB AND GUTTER AND MEDIAN CURB.



CITY COUNCIL APPROVAL: 01/24/2023

APPROVED BY CITY ENGINEER

APPROVED BY PUBLIC WORKS DIRECTOR

STREET WITH MEDIAN CROSS-SECTION

PUBLIC IMPROVEMENT STANDARDS

P-3

REVISIONS

NAME	BY	DATE

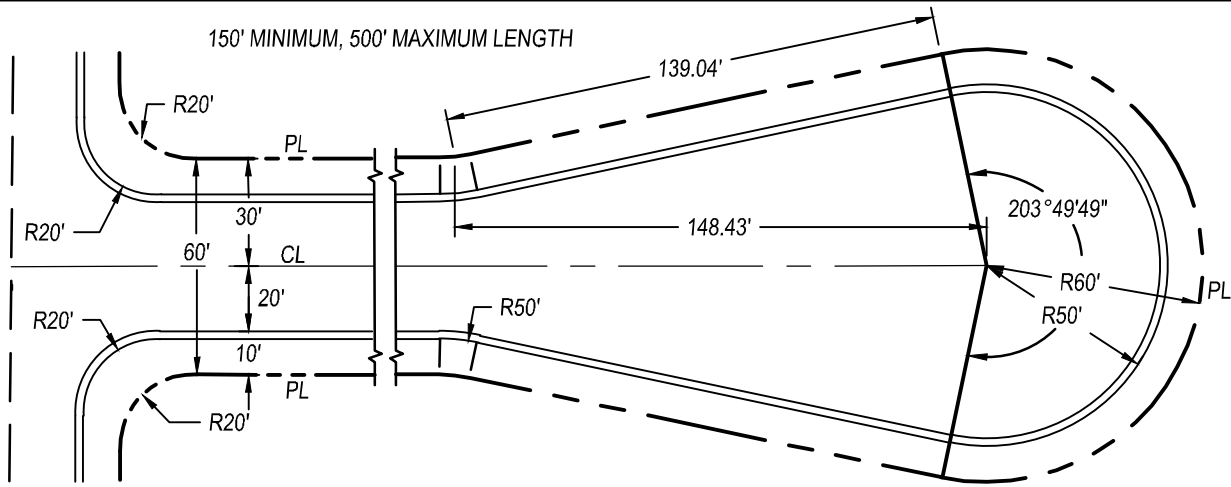

COMMERCIAL & INDUSTRIAL CUL-DE-SAC

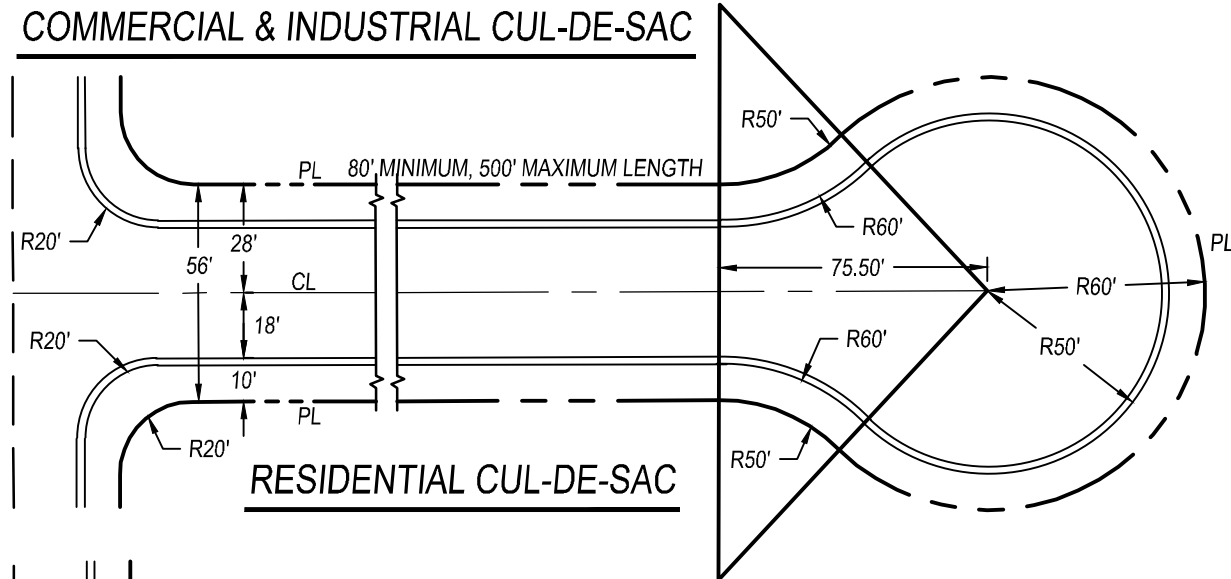

RESIDENTIAL CUL-DE-SAC

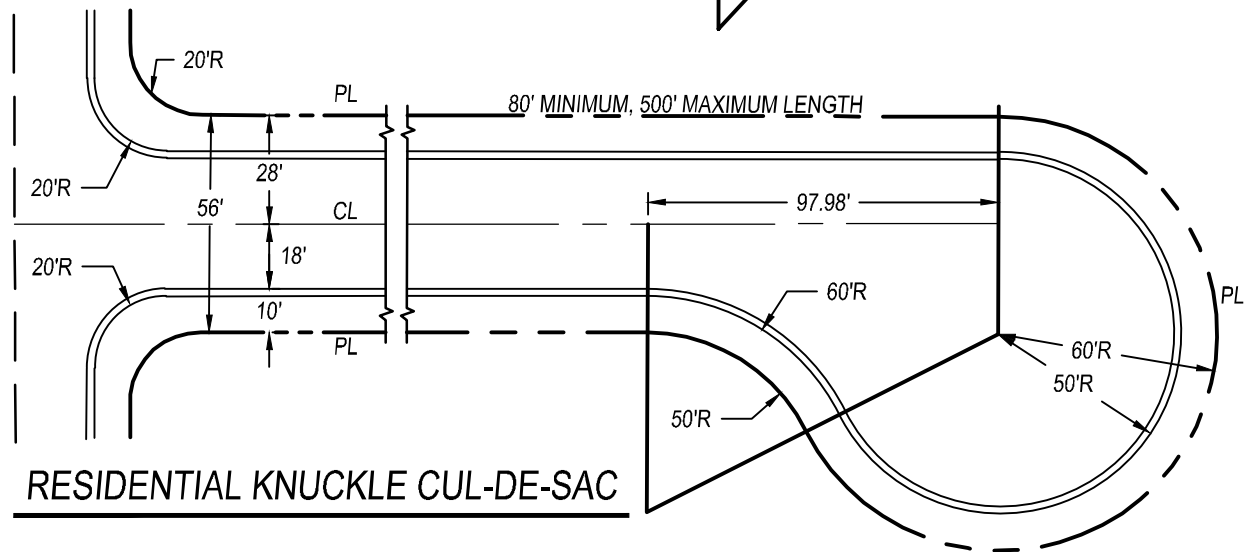

RESIDENTIAL KNUCKLE CUL-DE-SAC

NOTES:

- DESIGN TO PERMIT PARKING IN CUL-DE-SAC CENTERS ARE SUBJECT TO APPROVAL OF THE CITY ENGINEER



CITY COUNCIL APPROVAL: 01/24/2023

APPROVED BY CITY ENGINEER

APPROVED BY PUBLIC WORKS DIRECTOR

TYPICAL COMMERCIAL, INDUSTRIAL AND RESIDENTIAL CUL-DE-SAC PUBLIC IMPROVEMENT STANDARDS

P-4

REVISIONS

NAME	BY	DATE

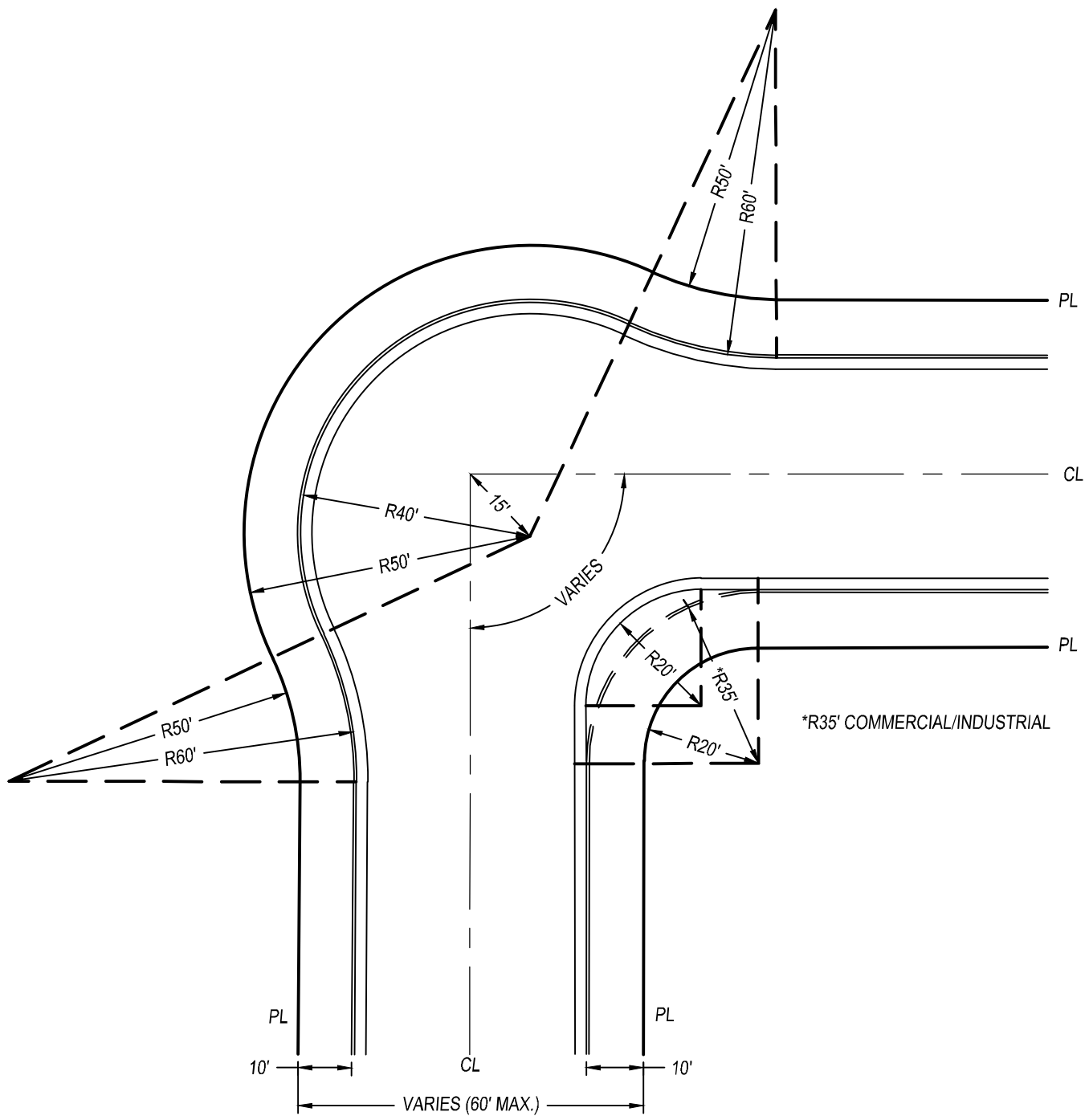

NOTES:

1. TYPICAL STREET BULB CONNECTION WITH 10' DISTANCE CURB FACE TO RIGHT OF WAY.



CITY COUNCIL APPROVAL: 01/24/2023
 APPROVED BY CITY ENGINEER
 APPROVED BY PUBLIC WORKS DIRECTOR

STREET KNUCKLE CONNECTIONS
PUBLIC IMPROVEMENT STANDARDS

P-5		
REVISIONS		
NAME	BY	DATE

NON-HIGH VISIBILITY CROSSWALK

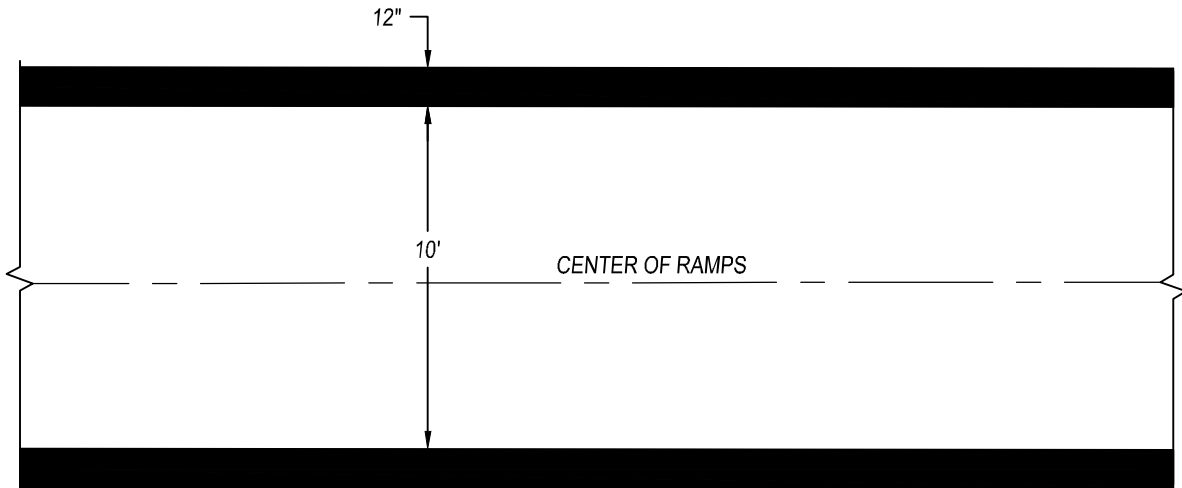

HIGH VISIBILITY CROSSWALK

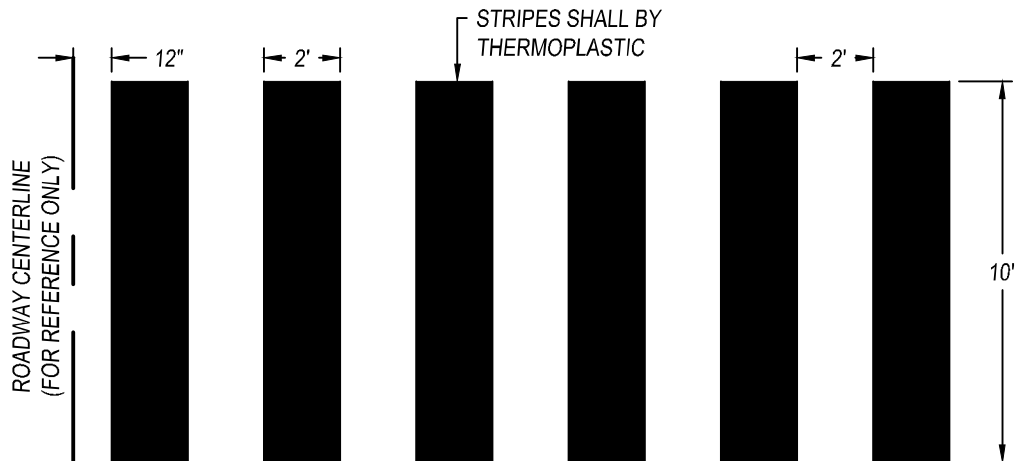

NOTES:

1. SCHOOL CROSSWALKS TO BE YELLOW PER THE LATEST EDITION OF THE CA MUTCD (OTHER PEDESTRIAN CROSSWALKS SHALL BE WHITE).
2. ALL PAVEMENT MARKINGS AND STRIPING SHALL BE THERMOPLASTIC WITH REFLECTIVE GLASS BEADS AND CONFORM TO THE LATEST VERSION OF THE CA MUTCD.



CITY COUNCIL APPROVAL: 01/24/2023

[Signature]
APPROVED BY CITY ENGINEER

[Signature]
APPROVED BY PUBLIC WORKS DIRECTOR

CROSSWALK MARKINGS

PUBLIC IMPROVEMENT STANDARDS

P-6

REVISIONS

NAME	BY	DATE

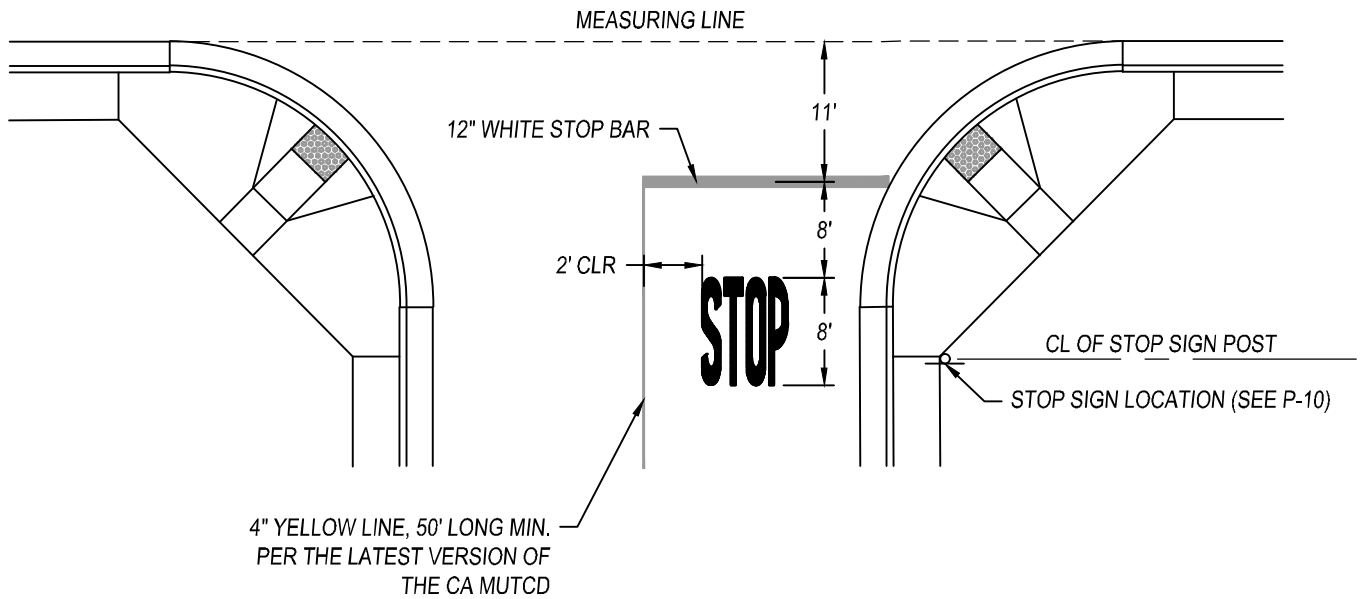

STANDARD STOP BAR MARKING

NOTES:

1. STRIPING/MARKINGS SHALL BE THERMOPLASTIC WITH REFLECTIVE GLASS BEADS AND SHALL CONFORM TO THE LATEST EDITION OF THE CA MUTCD.



CITY COUNCIL APPROVAL: 01/24/2023

 APPROVED BY CITY ENGINEER

 APPROVED BY PUBLIC WORKS DIRECTOR

**STOP BAR MARKING AND STOP
 SIGNS LOCATION
 PUBLIC IMPROVEMENT STANDARDS**

P-7		
REVISIONS		
NAME	BY	DATE

INSTALLATION REQUIREMENTS AND MATERIALS:

1. ATTACH SIGNS, SLEEVE AND ANCHOR TO POST WITH MULTI-GRIP DRIVE RIVETS ("UNISTRUT" TL-3806, OR APPROVED EQUAL).
2. POST, ANCHOR, SLEEVE AND MOUNTING HARDWARE SHALL BE GALVANIZED "UNISTRUT" TELSAPAR, OR APPROVED EQUAL, WITH 7/16" HOLE ON 1" CENTERS ON ALL FOUR (4) SIDES.
3. INSTALL SIGNS AND POST IN LOCATION APPROVED BY THE CITY ENGINEER OR PUBLIC WORKS DEPARTMENT.
4. ALL SIGNS ARE TO COMPLY WITH STATE STANDARDS, CONSTRUCTED OF .080 GAUGE ALUMINUM, STREET NAME SIGNS SHALL BE COVERED WITH 4" TYPE C HIGH INTENSITY SILVER LETTERS.
5. STREET SIGN HARDWARE: REFER TO TABLE BELOW, OR APPROVED EQUAL.
6. SAWCUT REQUIRED IF SIGN INSTALLED AFTER SIDEWALK IS POURED.
7. STOP SIGNS SHALL HAVE HIGH INTENSITY PRIZMATIC SHEETING, OR APPROVED EQUAL.
8. ALL SIGNS LOCATED IN SIDEWALK BY CITY APPROVAL ONLY.
9. STREET NAME SIGN SHALL BE HIGH INTENSITY PRIZMATIC SIGNS, OR APPROVED EQUAL.

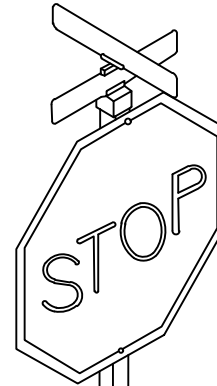

STREET SIGN HARDWARE TABLE

MANUFACTURER	BLADE LENGTH BLADE HARDWARE STYLE	
	ZUMAR MANUFACTURING	24" 606F

APPROVED ABBREVIATIONS

COURT.....CT	CIRCLE.....CR
STREET.....ST	DRIVE.....DR
AVENUE.....AVE	ROAD.....RD
PLACE.....PL	LANE.....LN
BOULEVARD..BLVD	

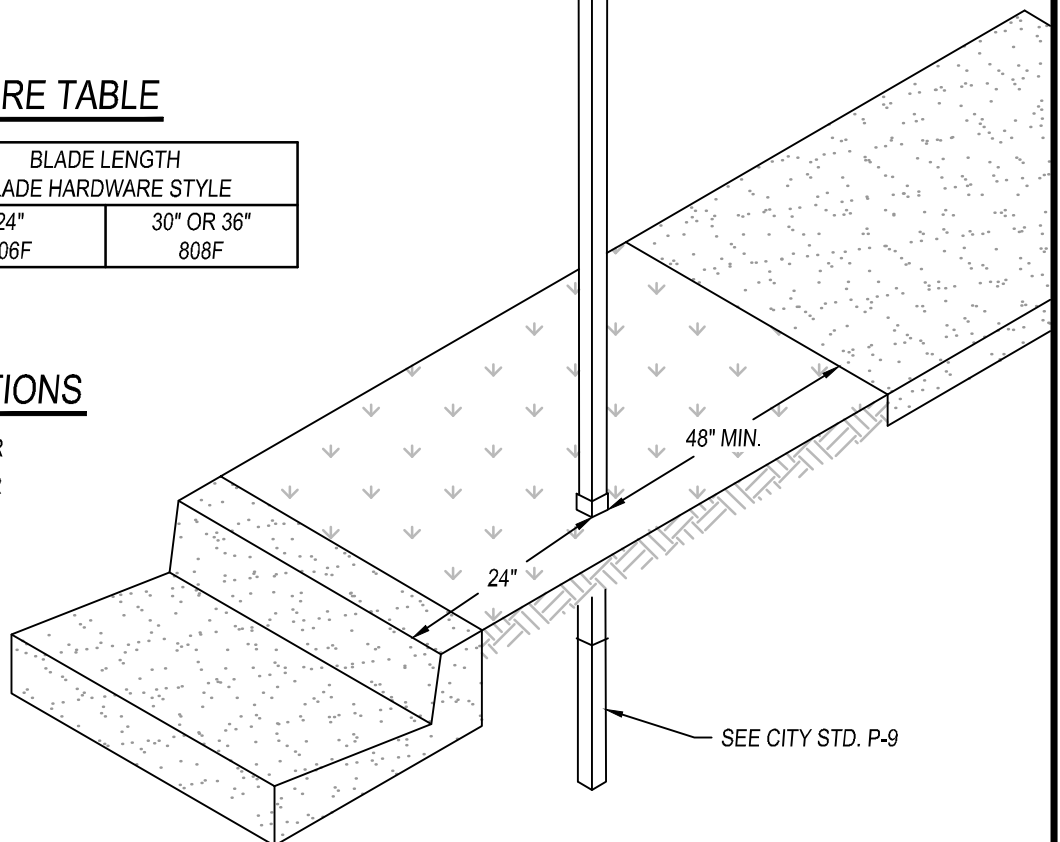

CITY COUNCIL APPROVAL: 01/24/2023

APPROVED BY CITY ENGINEER

APPROVED BY PUBLIC WORKS DIRECTOR

STREET SIGN STANDARD (1 OF 2)

PUBLIC IMPROVEMENT STANDARDS

P-8

REVISIONS

NAME	BY	DATE

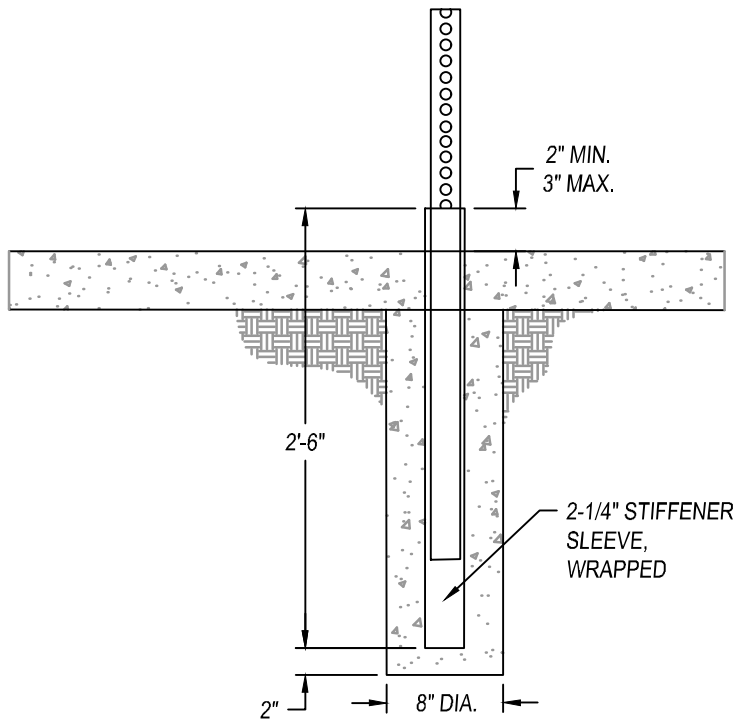

POST INSTALLATION DETAIL

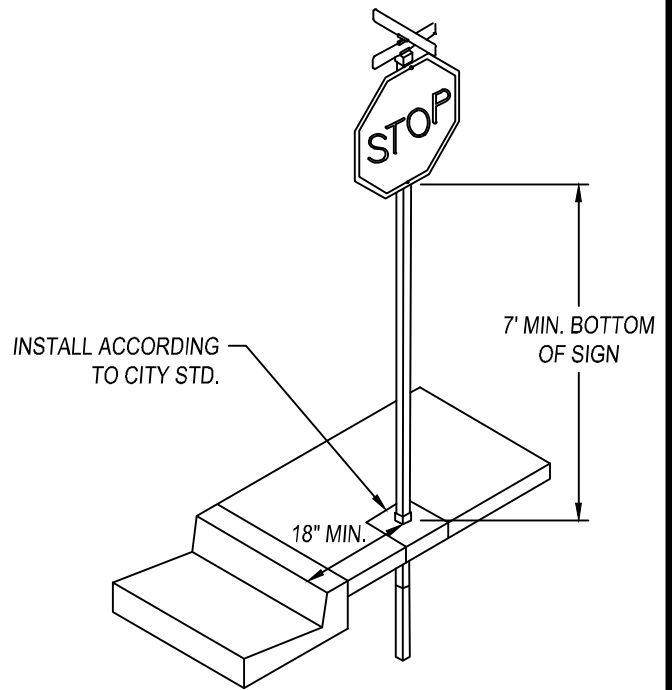

5' - 0' SIDEWALK INSTALLATION DETAIL

PRIOR APPROVAL NEEDED FROM PUBLIC WORKS DEPARTMENT

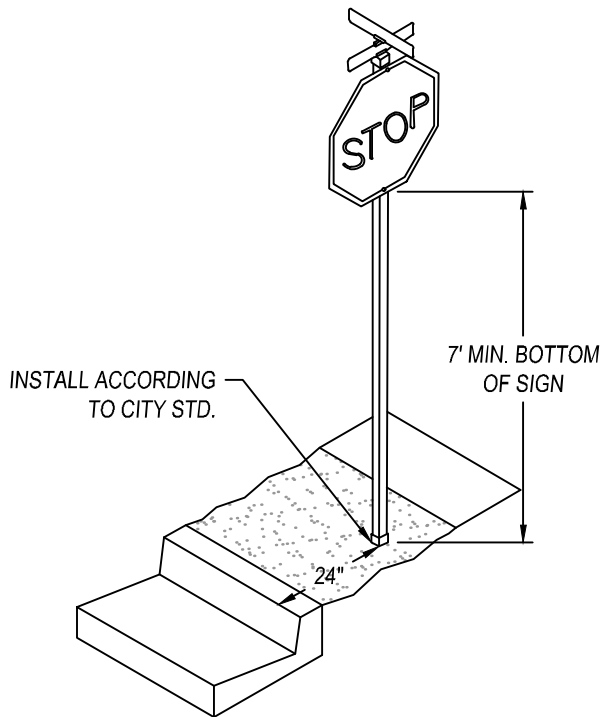

DETACH SIDEWALK INSTALLATION DETAIL

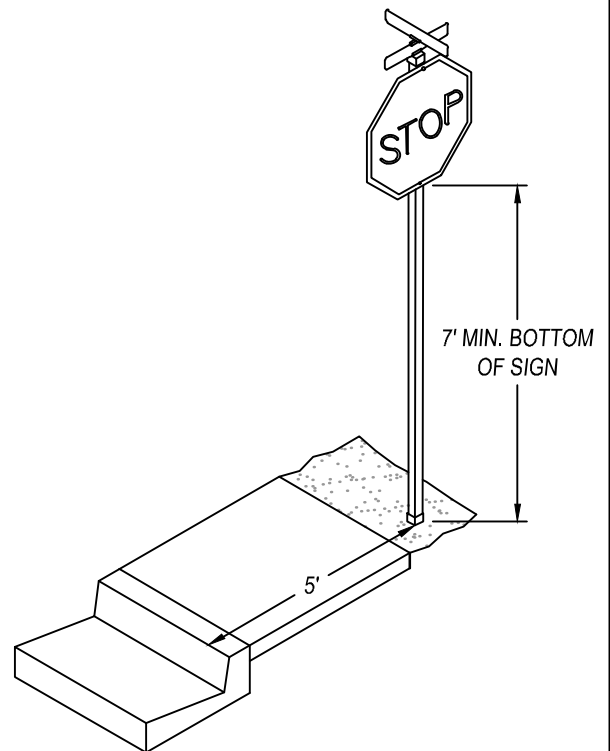

4'-0" SIDEWALK INSTALLATION DETAIL



CITY COUNCIL APPROVAL: 01/24/2023

APPROVED BY CITY ENGINEER
 APPROVED BY PUBLIC WORKS DIRECTOR

STREET SIGN INSTALLATION (2 OF 2)

PUBLIC IMPROVEMENT STANDARDS

P-9

REVISIONS

NAME	BY	DATE

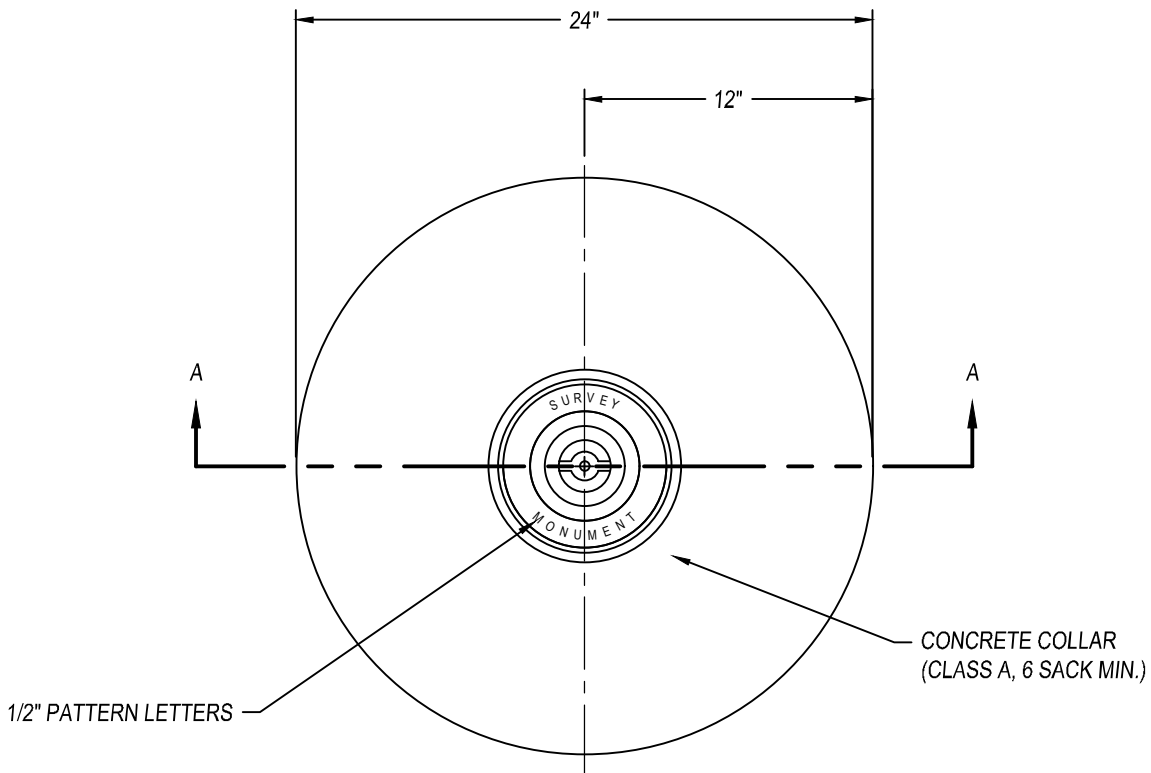

PLAN

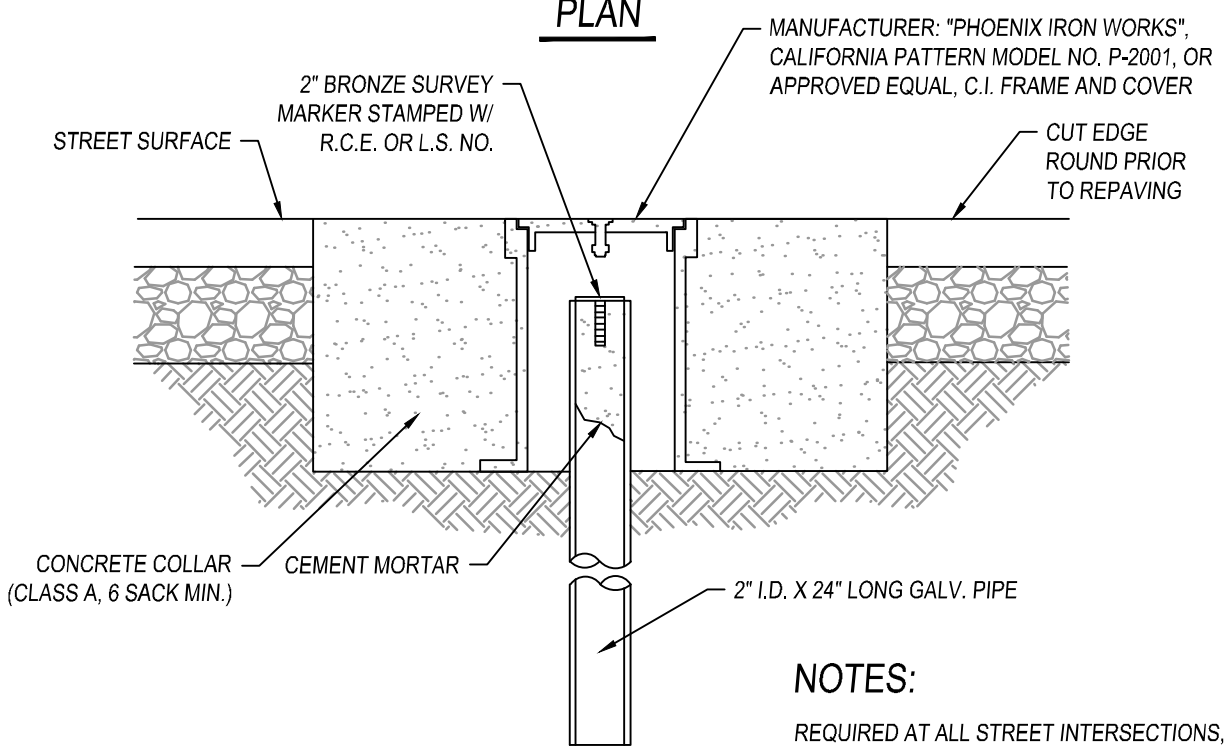

SECTION A-A

NOTES:
 REQUIRED AT ALL STREET INTERSECTIONS,
 STREET OFF-SETS, CUL-DE-SACS AND STREET
 RADIUS POINTS.



CITY COUNCIL APPROVAL: 01/24/2023
 APPROVED BY CITY ENGINEER
 APPROVED BY PUBLIC WORKS DIRECTOR

**TYPE-A STREET INTERSECTION AND
 CURVE RADIUS SURVEY MONUMENT
 PUBLIC IMPROVEMENT STANDARDS**

P-10		
REVISIONS		
NAME	BY	DATE

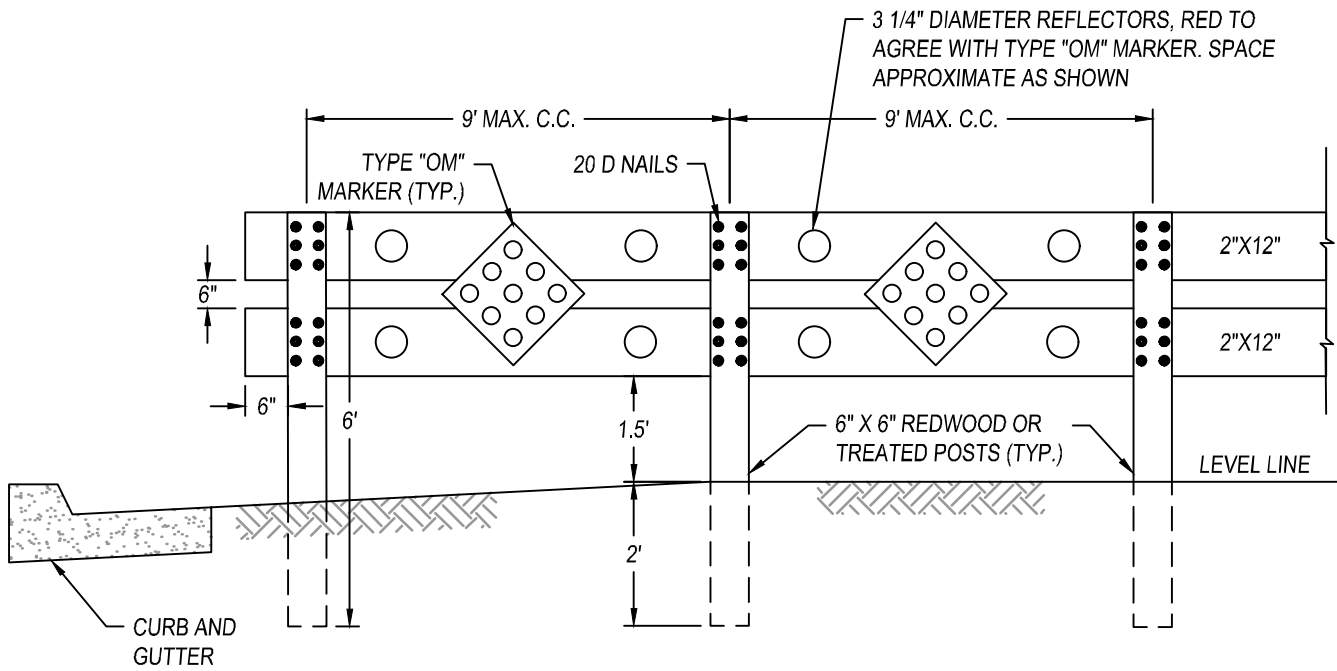

NOTES:

1. BARRICADES SHALL BE 2 FEET LESS THAN FULL WIDTH OF PAVEMENT OR TRAVELED WAY, OR AS SHOWN ON PROJECT PLANS.
2. APPLY TWO COATS OF EXTERIOR FLAT WHITE PAINT TO ALL EXPOSED WOOD MEMBERS.
3. ANY DEVIATION FROM THE ABOVE FOR TEMPORARY INSTALLATIONS, SHALL BE SUBJECT TO APPROVAL OF THE CITY ENGINEER.
4. UPRIGHT POSTS SHALL BE REDWOOD OR PRESSURE-TREATED DOUGLAS FIR.
5. ALTERNATE HORIZONTAL LAPS WHERE POSSIBLE.
6. STATE OF CALIFORNIA OM4-1, RED REFLECTORIZED SIGN WITH 9 RED REFLECTORS AT DEAD END STREETS.
7. MUTCD SIGN OM1-1, YELLOW REFLECTORIZED SIGN WITH 9 YELLOW REFLECTORS AND W1-6 OR W1-7 AT "T" OR "L" INTERSECTIONS.
8. REFLECTORIZED SIGNS ARE TO BE INSTALLED AT A HEIGHT AND POSITION.



CITY COUNCIL APPROVAL: 01/24/2023

[Signature]
APPROVED BY CITY ENGINEER

[Signature]
APPROVED BY PUBLIC WORKS DIRECTOR

TIMBER BARRICADE

PUBLIC IMPROVEMENT STANDARDS

P-11

REVISIONS

NAME	BY	DATE

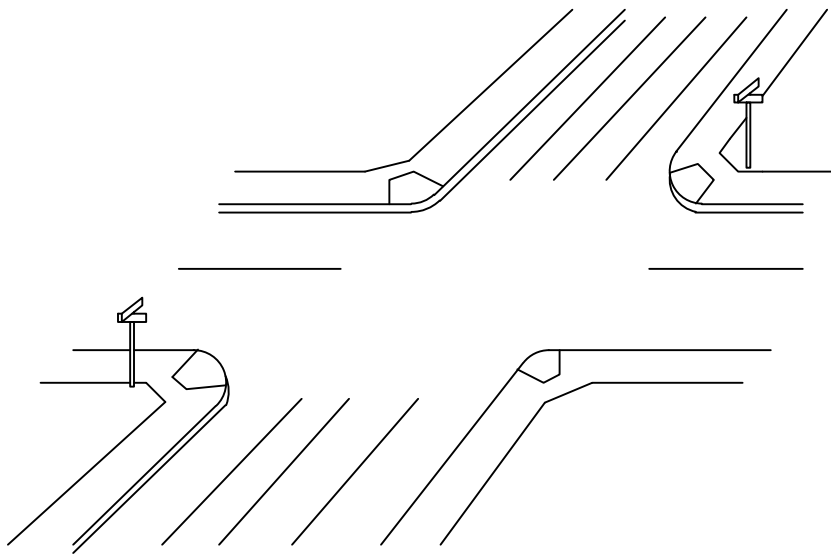

LOCATION AT INTERSECTION

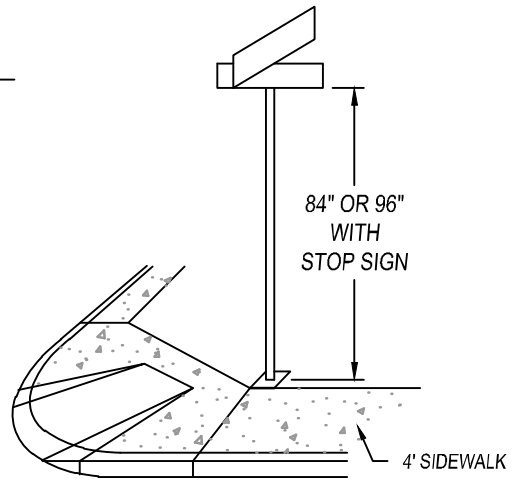

LOCATION IN 4 FT. MONOLITHIC SIDEWALK

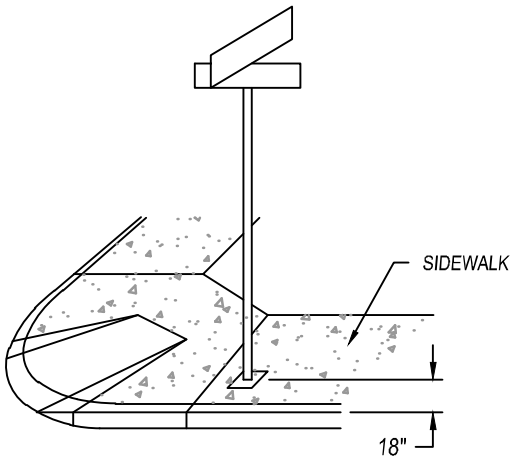

LOCATION IN FULL WIDTH SIDEWALK

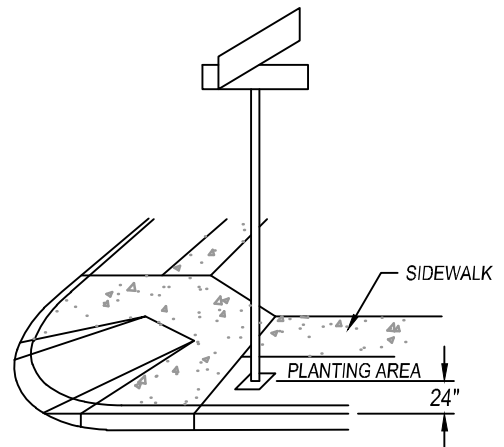

LOCATION IN PLANTING STRIP

NOTES:

1. SAWCUT REQUIRED IF SIGN INSTALLED AFTER SIDEWALK IS POURED.
2. WHEN INSTALLED IN SIDEWALK, POLES WILL BE SET PRIOR TO SIDEWALK POUR.
3. SAME PIPE FOR STOP SIGN AND STREET NAME SIGN MAY BE UTILIZED WHERE APPROVED.



CITY COUNCIL APPROVAL: 01/24/2023

[Signature]
APPROVED BY CITY ENGINEER

[Signature]
APPROVED BY PUBLIC WORKS DIRECTOR

STREET NAME SIGN LOCATION

PUBLIC IMPROVEMENT STANDARDS

P-12

REVISIONS

NAME	BY	DATE

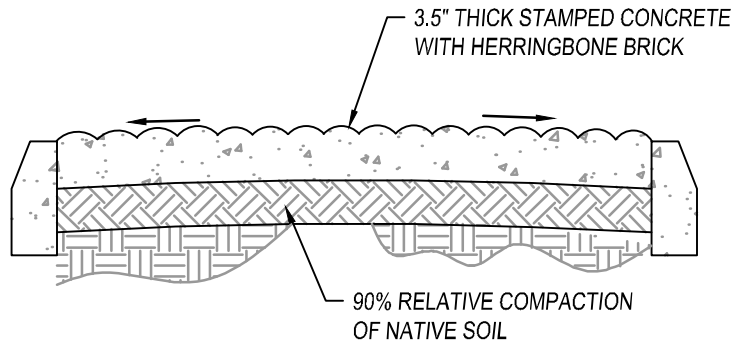

SECTION A-A

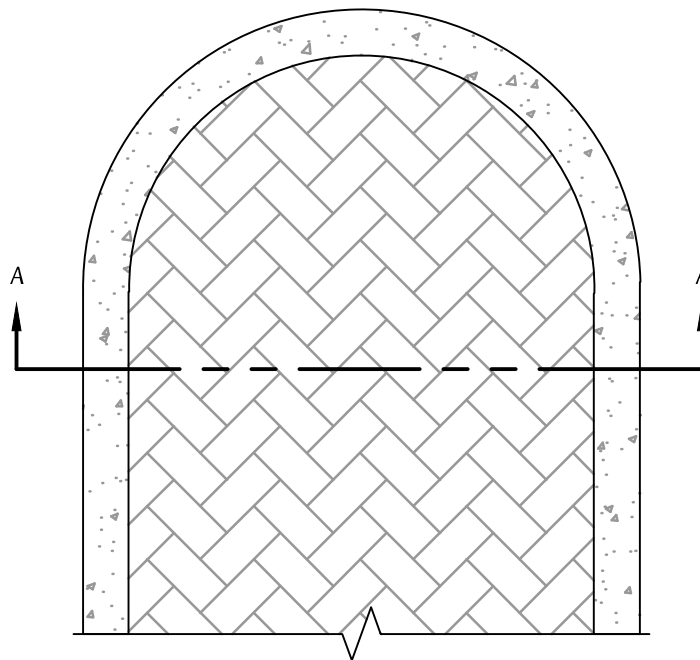

PLAN

NOTES:

1. CONCRETE STAMPED SHALL BE A HERRINGBONE BRICK PATTERN AND BE DAVIS IN COLOR BRICK RED.
2. LIQUID RELEASE AGENT SHALL BE USED.
3. CURE AND SEAL PRODUCT SHALL BE APPLIED IN ACCORDANCE TO THE MANUFACTURER'S RECOMMENDATIONS.



CITY COUNCIL APPROVAL: 01/24/2023

[Signature]
APPROVED BY CITY ENGINEER

[Signature]
APPROVED BY PUBLIC WORKS DIRECTOR

DECORATIVE STAMPED
CONCRETE MEDIAN

PUBLIC IMPROVEMENT STANDARDS

P-13		
REVISIONS		
NAME	BY	DATE

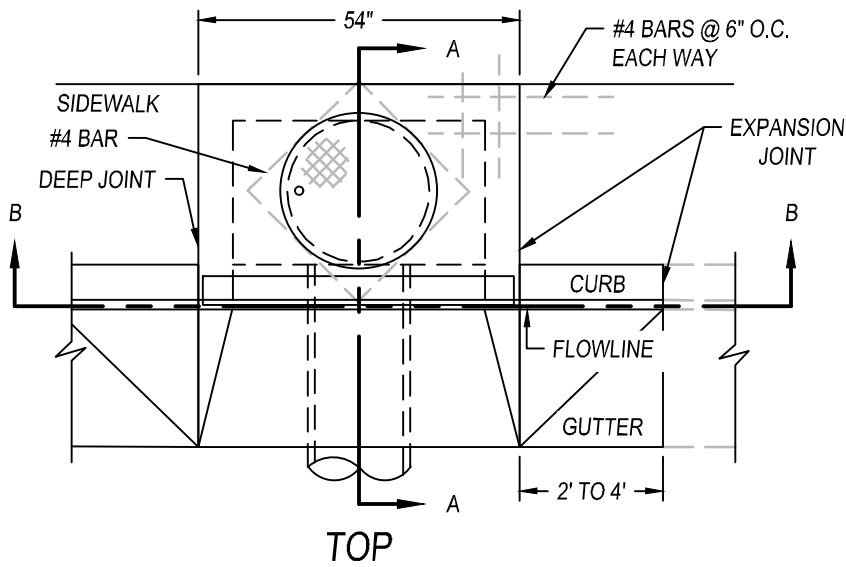

INLET/OUTLET

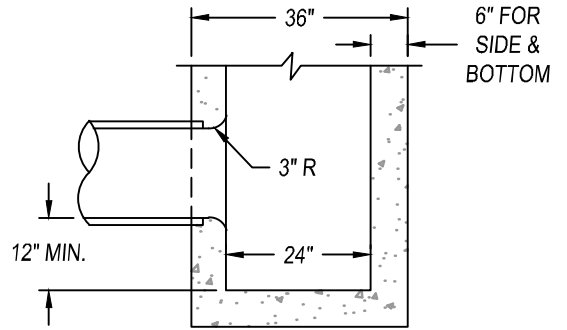

SECTION A-A

OUTLET SEE NOTE 2

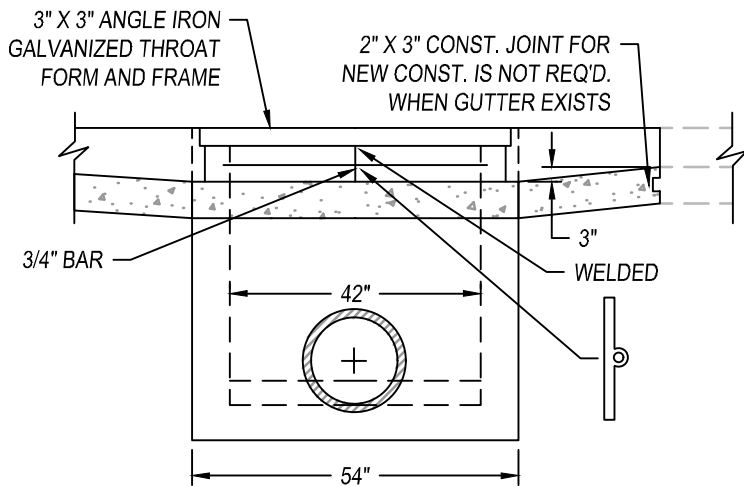

SECTION B-B FRONT

INLET/OUTLET
(CUTTING PLANE IS AT FLOWLINE)

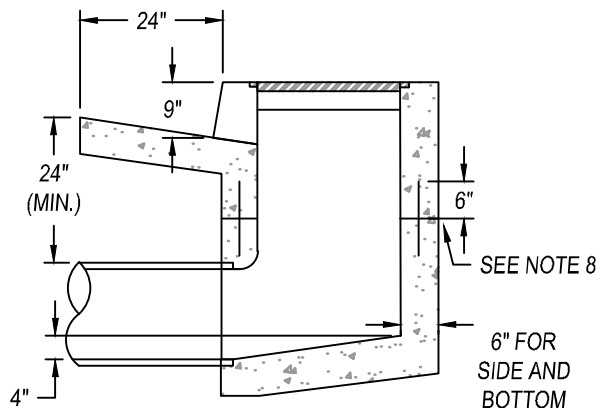

SECTION B-B

INLET

NOTES:

1. AN OUTLET STRUCTURE THROAT SHALL BE FORMED WITH 6" FROM FLOWLINE TO TOP OF CURB.
2. WHEN EMPLOYED AS OUTLET, ELIMINATE THE 1/2" DIA. ROD AND PLACE GALV. FRAME AND GRATE 6" BELOW TOP OF CURB.
3. THE INLET OR OUTLET MAY BE MODIFIED SLIGHTLY TO MATCH EXISTING IMPROVEMENTS, AS DIRECTED BY THE CITY.
4. STRUCTURE SHALL BE CLASS "A" CONCRETE (6 SACK MINIMUM). CURB, GUTTER AND LOCAL DEPRESSIONS SHALL BE CLASS "A" CONCRETE (5 SACK MINIMUM).
5. CURB AND GUTTER SHALL BE RECONSTRUCTED ON EACH SIDE OF BOX AS INDICATED ON THE PLANS.
6. THE FLOOR OF THE INLET SHALL SLOPE FROM ALL WALLS TO THE LAT. FLOWLINE AND BE GIVEN A STEEL TROWELED FINISH.
7. AT THE CONTACT POINT OF THE STRUCTURE WALL AND THE LATERAL, A SMOOTH 3" RADIUS CURVE SHALL BE CONSTRUCTED.
8. IF THE STRUCTURE IS CONSTRUCTED IN A TWO-STAGE POUR, PROVIDE A ROUGHENED CONSTRUCTION JOINT AND PLACE ON #4 REBAR, 12" LONG, IN EACH OF THE FOUR WALLS, AS SHOWN.
9. APPROVAL EQUAL: "CHRISTY" U36 PRE-CAST CONCRETE CATCH BASIN WITH U37 (2 X 4) PRE-CAST CONCRETE CURB INLET.
10. MAXIMUM GUTTER SHALL NOT EXCEED 1,300'.



CITY COUNCIL APPROVAL: 01/24/2023

APPROVED BY CITY ENGINEER

APPROVED BY PUBLIC WORKS DIRECTOR

**TYPE 'A' CATCH BASIN
42" CURB INLET AND 42" BASIN**

PUBLIC IMPROVEMENT STANDARDS

SD-1

REVISIONS

NAME	BY	DATE

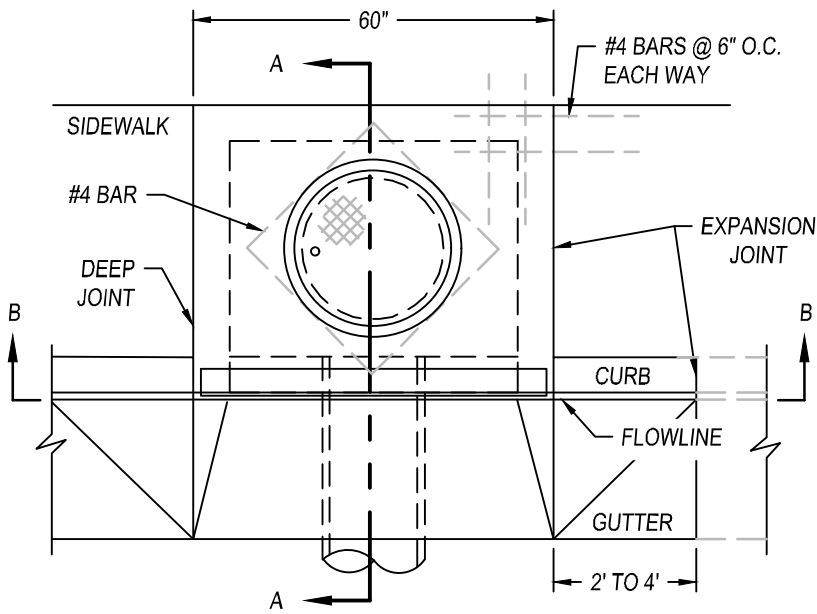

TOP
INLET/OUTLET

NOTES:

1. AN OUTLET STRUCTURE THROAT SHALL BE FORMED 6" FROM FLOWLINE TO TOP OF CURB.
2. THE INLET/OUTLET MAY BE MODIFIED SLIGHTLY TO MATCH EXISTING IMPROVEMENTS, AS DIRECTED BY THE CITY ENGINEER.
3. STRUCTURE SHALL BE CLASS "A" CONCRETE (6 SACK MINIMUM). CURB, GUTTER AND LOCAL DEPRESSIONS SHALL BE CLASS "A" CONCRETE.
4. REINFORCING STEEL SHALL BE #4 DEFORMED BARS. INSTALL (2) #4 @ 24" O.C. 2" FROM AND ADJACENT TO COVER FOR ADDITIONAL STRENGTH.
5. SPECIAL DESIGN MAY BE REQUIRED BY THE CITY ENGINEER WHEN DEPTH OF CATCH BASIN EXCEEDS 6 FEET.
6. APPROVED EQUAL: "CHRISTY" U52 PRE-CAST CONCRETE CATCH BASIN MANHOLE LID AND FRAME. (SEE CITY STD. SS-9)
7. MAXIMUM GUTTER RUN SHALL NOT EXCEED 1,300'.

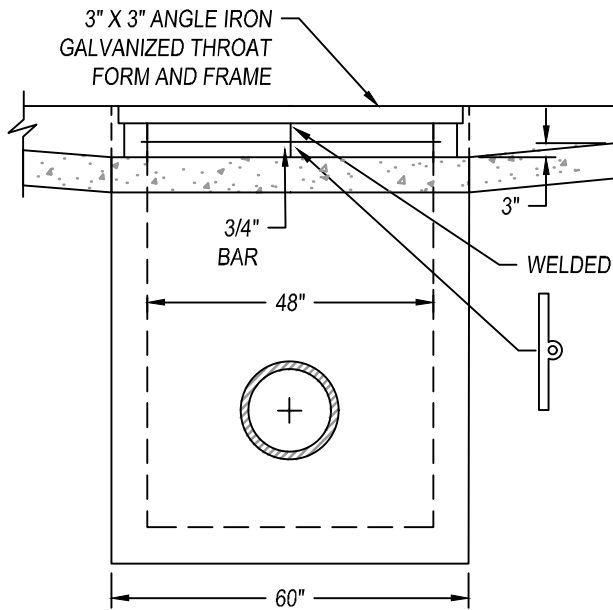

SECTION B-B FRONT
INLET/OUTLET
(CUTTING PLANE IS AT FLOWLINE)

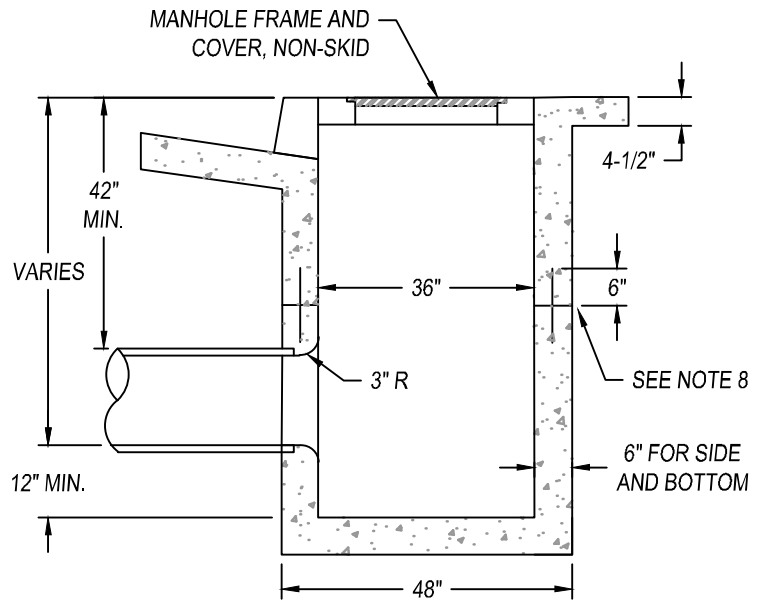

SECTION A-A
INLET/OUTLET



CITY COUNCIL APPROVAL: 01/24/2023
 APPROVED BY CITY ENGINEER
 APPROVED BY PUBLIC WORKS DIRECTOR

**TYPE 'B' CATCH BASIN 48" CURB
 INLET AND 48X36" BASIN**
PUBLIC IMPROVEMENT STANDARDS

SD-2		
REVISIONS		
NAME	BY	DATE

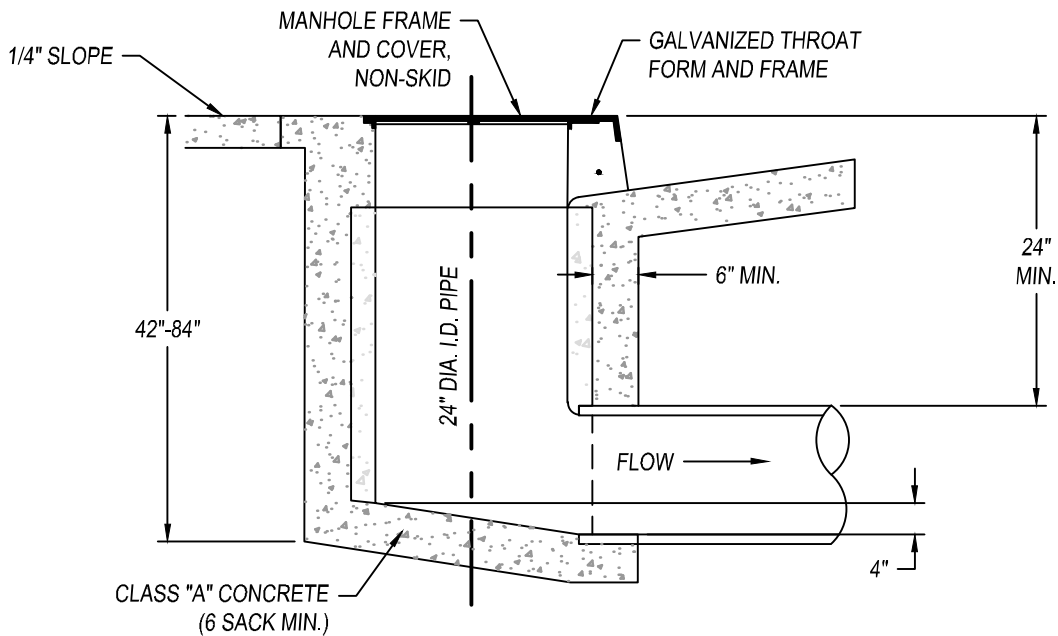
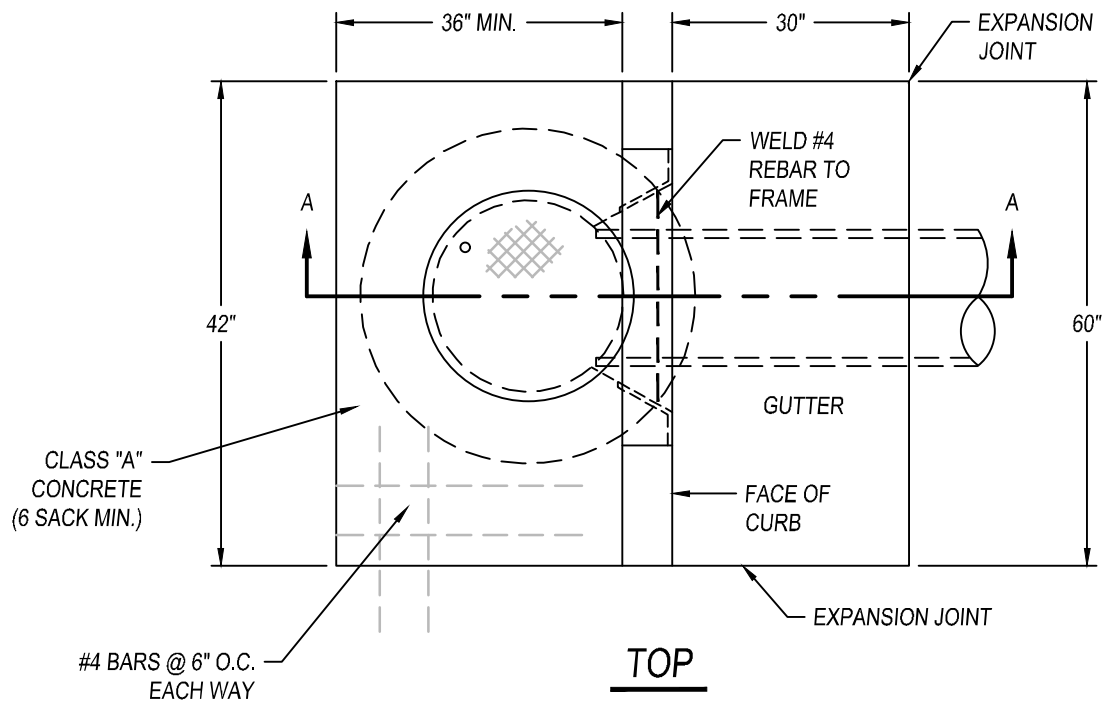

SECTION A-A

NOTES:

1. BY CITY STAFF APPROVAL ONLY.
2. MAXIMUM GUTTER RUN NOT TO EXCEED 1,300'.



CITY COUNCIL APPROVAL: 01/24/2023

APPROVED BY CITY ENGINEER

APPROVED BY PUBLIC WORKS DIRECTOR

**TYPE 'C' CATCH BASIN 24"
DIAMETER INLET DRAIN PIPE**

PUBLIC IMPROVEMENT STANDARDS

SD-3

REVISIONS

NAME	BY	DATE

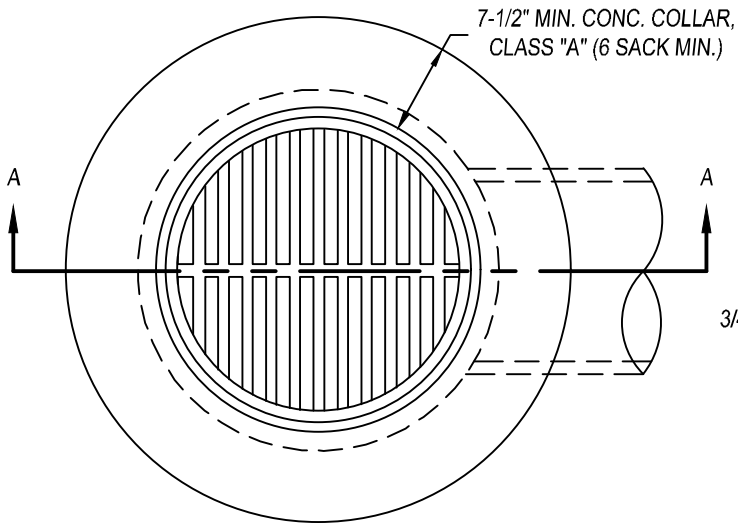

TOP

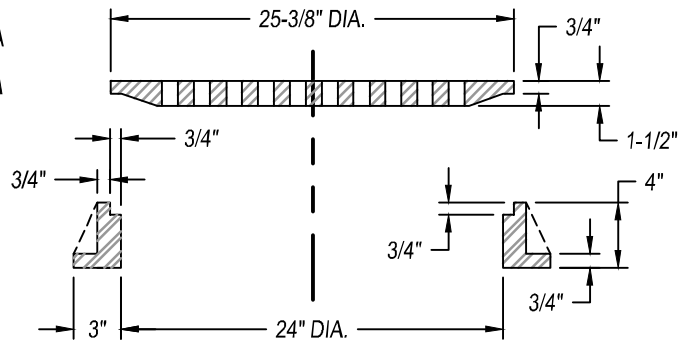

FRAME AND COVER

SIDE-VIEW SECTION

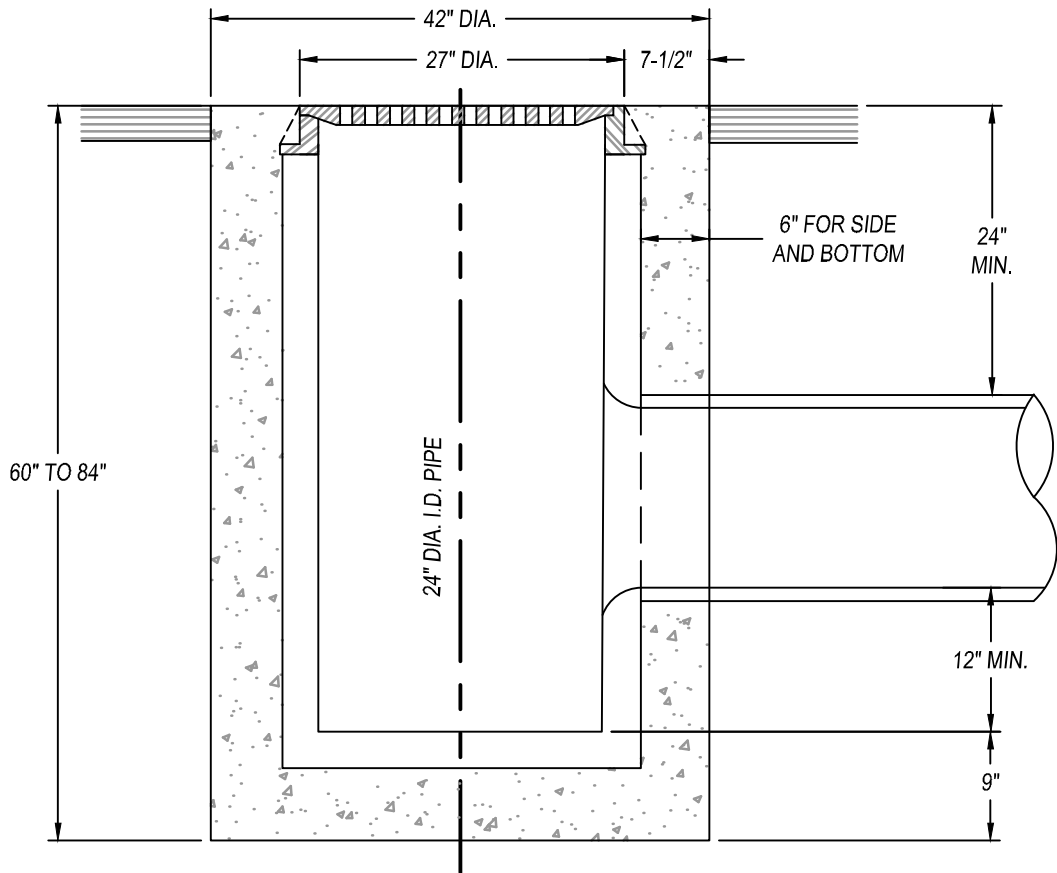

SECTION A-A

NOTES:

1. BY CITY STAFF APPROVAL ONLY.



CITY COUNCIL APPROVAL: 01/24/2023
 APPROVED BY CITY ENGINEER
 APPROVED BY PUBLIC WORKS DIRECTOR

**TYPE 'D' CATCH BASIN
 STANDARD FLAT GRATE**

PUBLIC IMPROVEMENT STANDARDS

SD-4

REVISIONS

NAME	BY	DATE

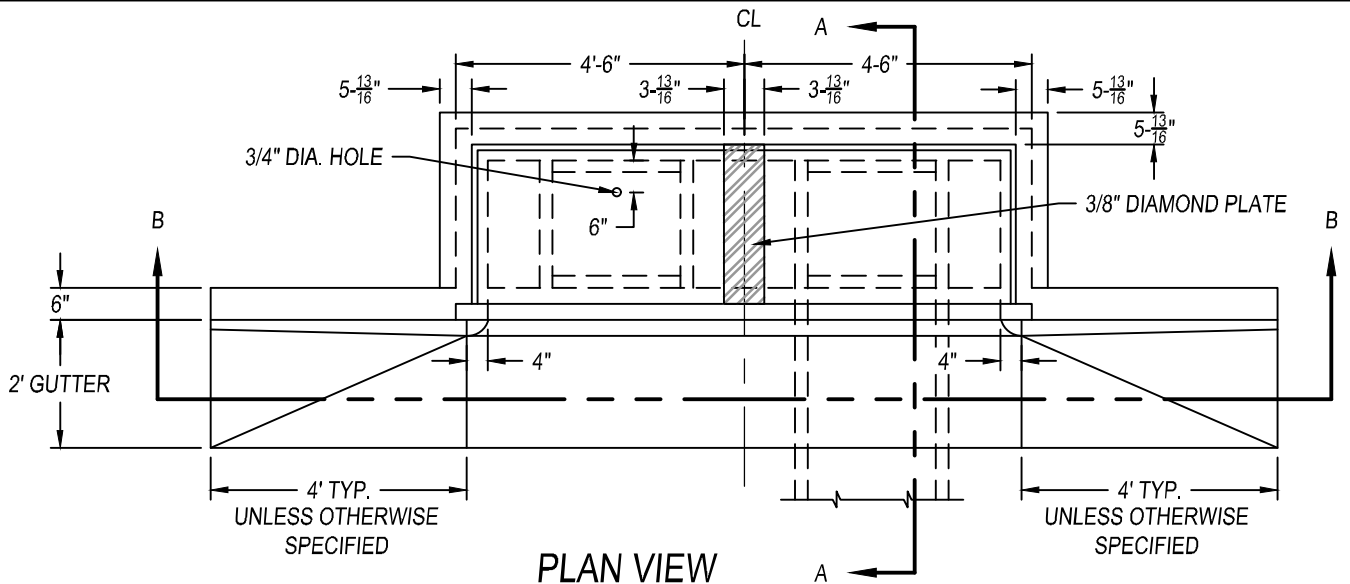

PLAN VIEW

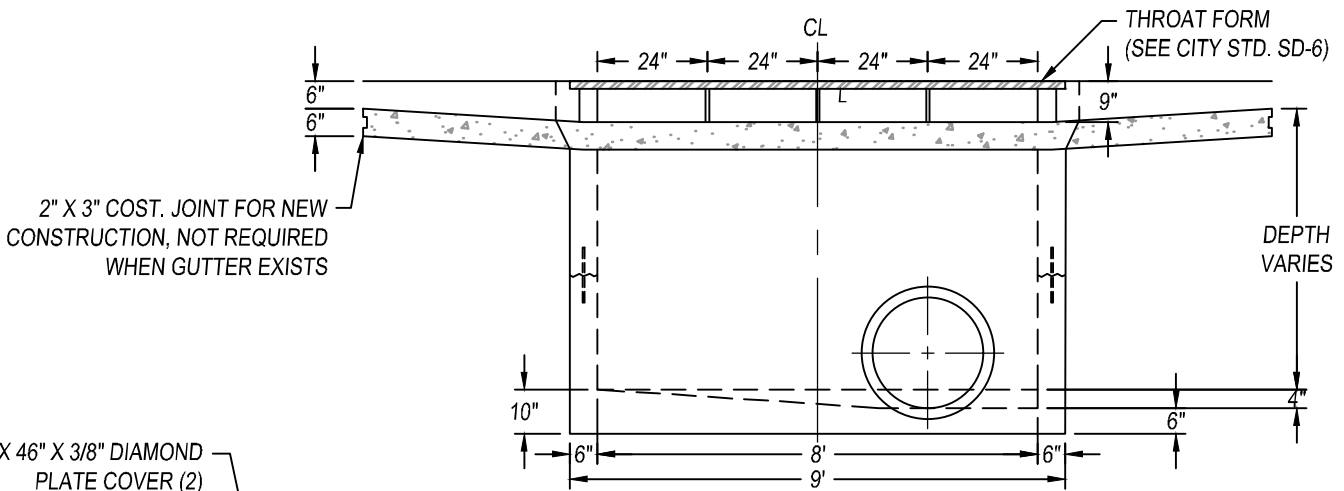

SECTION B-B

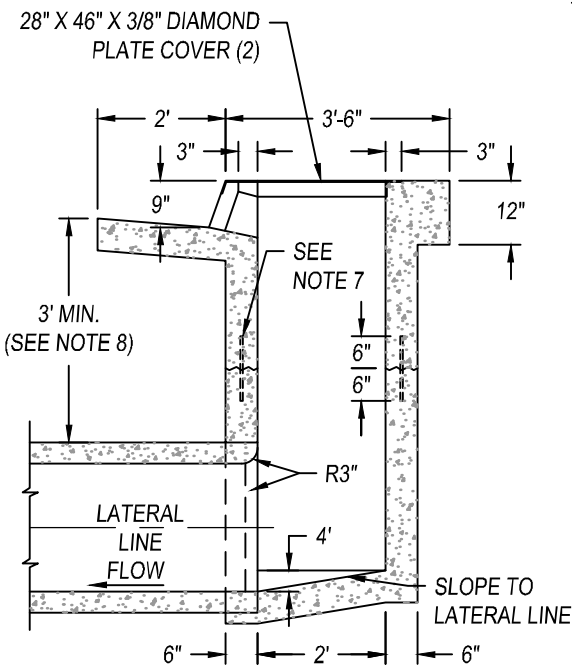

SECTION A-A

NOTES:

1. THE INLET MAY BE MODIFIED SLIGHTLY TO MATCH EXISTING IMPROVEMENTS, AS DIRECTED BY THE ENGINEER.
2. STRUCTURE SHALL BE CLASS "A" CONCRETE (6 SACK MIN.). EXPOSED SURFACES SHALL BE FINISHED AS PER CURB SPECIFICATIONS.
3. COST OF FRAME, THROAT FORM, AND CURB AND GUTTER WINGS SHALL BE INCLUDED IN PRICE OF INLET.
4. ADDITIONAL CURB AND GUTTER SHALL BE CONSTRUCTED OR RECONSTRUCTED ON EACH SIDE OF BOX AS INDICATED ON THE PLANS AND COST THEREOF SHALL BE INCLUDED IN PRICE OF INLET.
5. FLOOR OF THE INLET SHALL SLOPE FROM ALL WALLS TO THE LATERAL LINE AND SHALL BE GIVEN A STEEL TROWELED FINISH.
6. AT THE CONTACT POINT BETWEEN THE LATERAL LINE AND THE INLET WALL A SMOOTH 3" RADIUS CURVE SHALL BE CONSTRUCTED.
7. IN INLET IS CONSTRUCTED IN A TWO STAGE POUR, PROVIDE A ROUGHENED CONSTRUCTION JOINT AND PLACE ONE #4 BAR 12" LONG IN EACH OF THE FOUR WALLS, AS SHOWN.
8. PIPE MINIMUM DEPTH MAY BE ADJUSTED BY THE DESIGNER OR ENGINEER. MAY REQUIRE PIPE CLASS CHANGE OR SPECIAL BACKFILL.



CITY COUNCIL APPROVAL: 01/24/2023
 APPROVED BY CITY ENGINEER
 APPROVED BY PUBLIC WORKS DIRECTOR

**DOUBLE TYPE 'D' INLET
 (SHEET 1 OF 2)**

PUBLIC IMPROVEMENT STANDARDS

SD-5		
REVISIONS		
NAME	BY	DATE

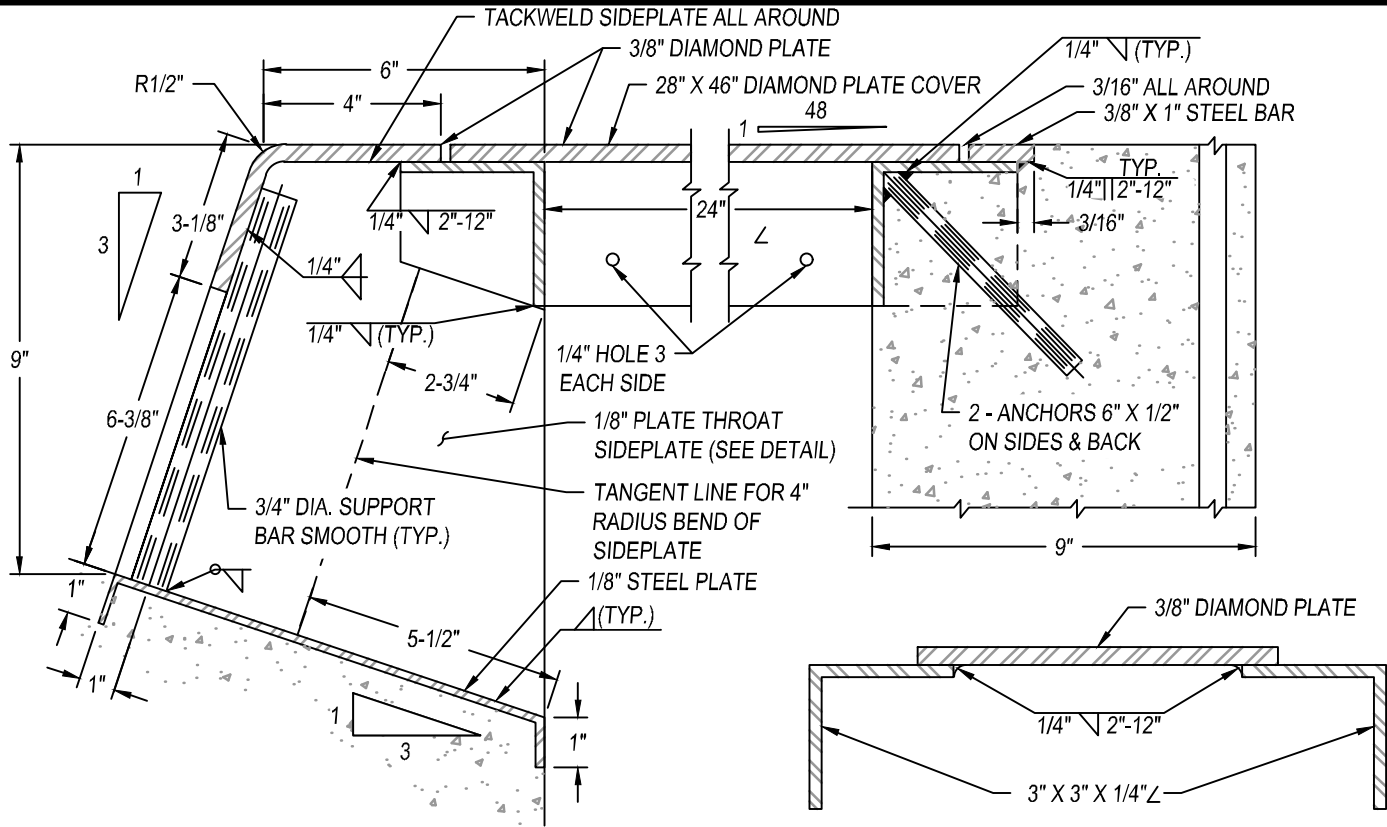

SECTION A-A

SECTION B-B

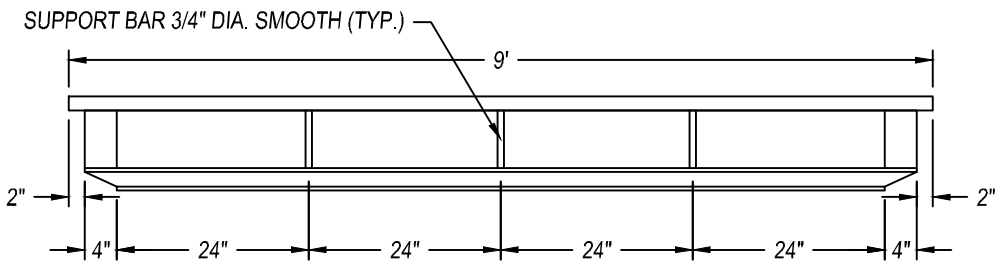

FRONT

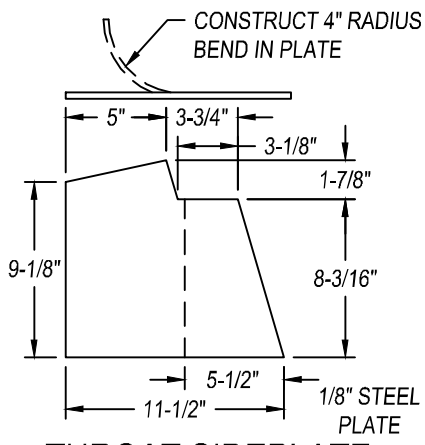

THROAT SIDEPLATE

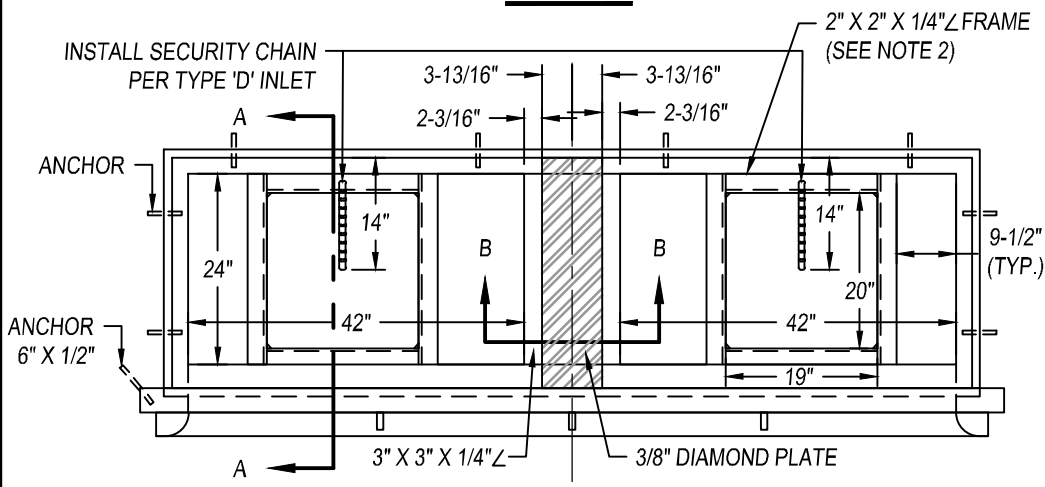

PLAN

- NOTES:**
1. ALL EXPOSED METAL PARTS SHALL BE PAINTED OR DIPPED WITH A BLACK ASPHALTUM PAINT OR OTHER COATING APPROVED BY THE ENGINEER.
 2. INSTALL 2 FRAMES AFTER INLET IS CONSTRUCTED. TOP SURFACE TO BE FLUSH WITH INLET FRAME. WELD TO INLET FRAME ON UNDERNEATH SIDE.



CITY COUNCIL APPROVAL: 01/24/2023
 APPROVED BY CITY ENGINEER
 APPROVED BY PUBLIC WORKS DIRECTOR

DOUBLE TYPE 'D' INLET
(SHEET 2 OF 2)
PUBLIC IMPROVEMENT STANDARDS

SD-6		
REVISIONS		
NAME	BY	DATE

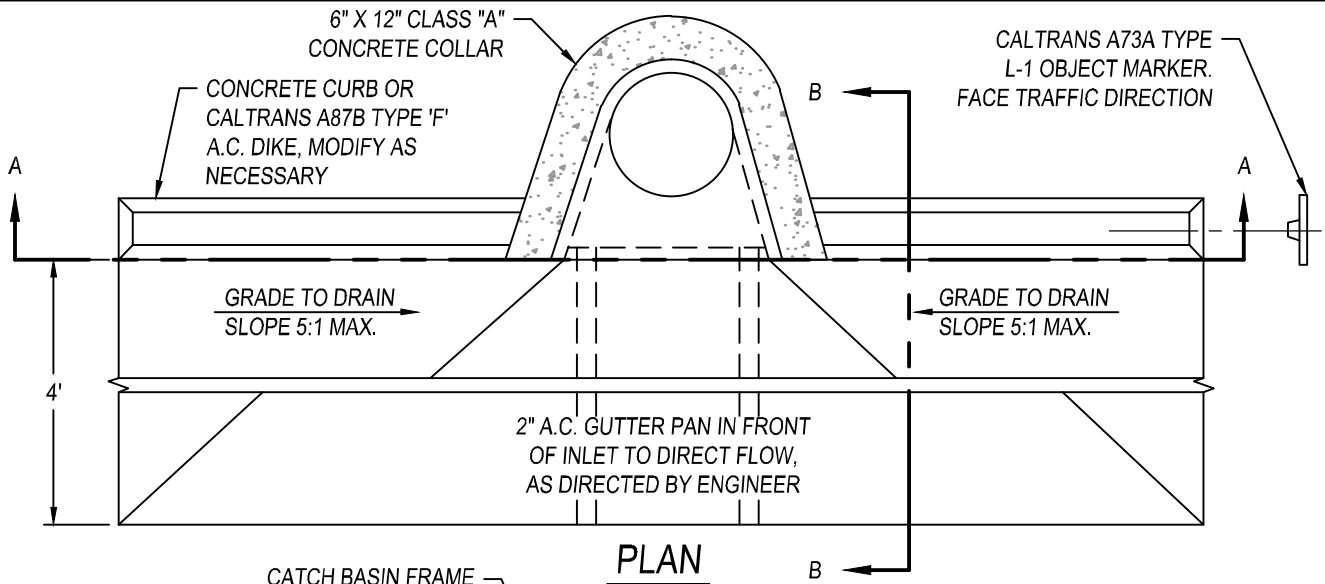

PLAN

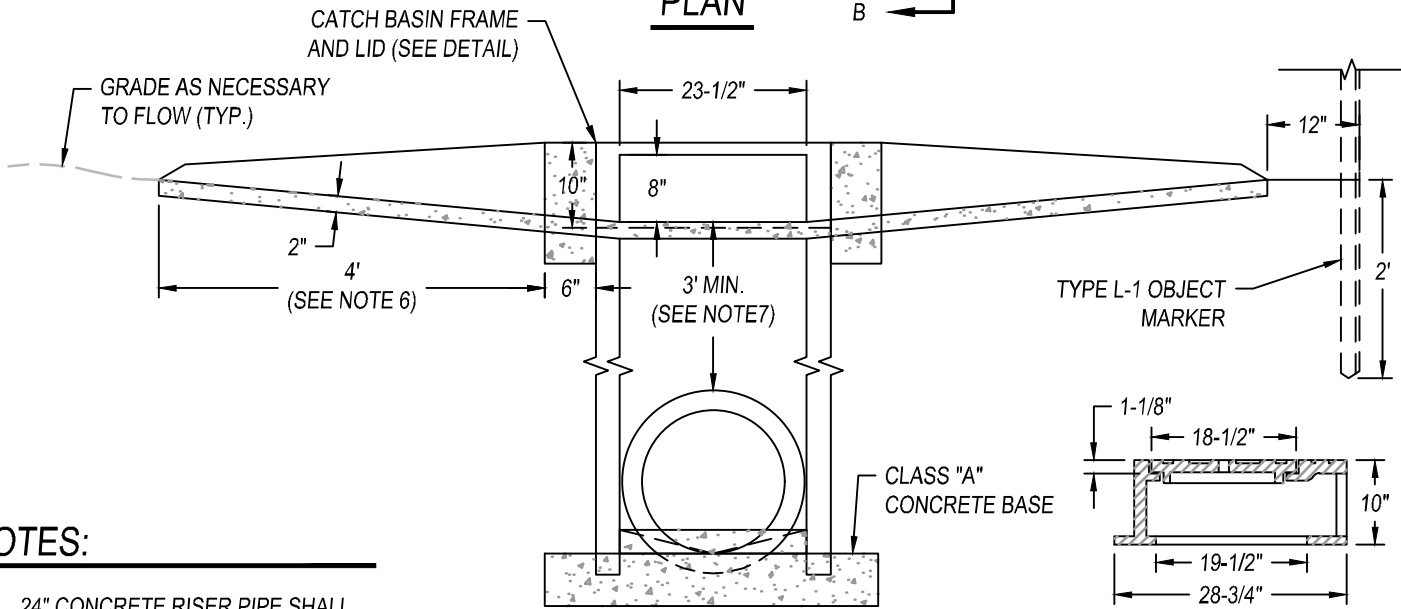

SECTION A-A

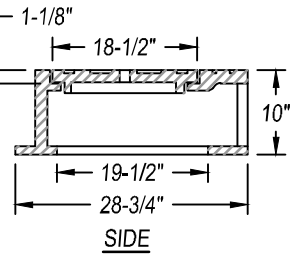

SIDE

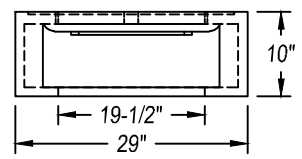

FRONT

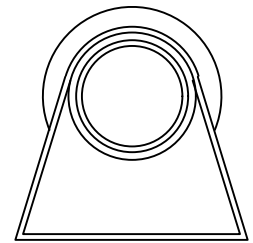

PLAN
LID DETAIL

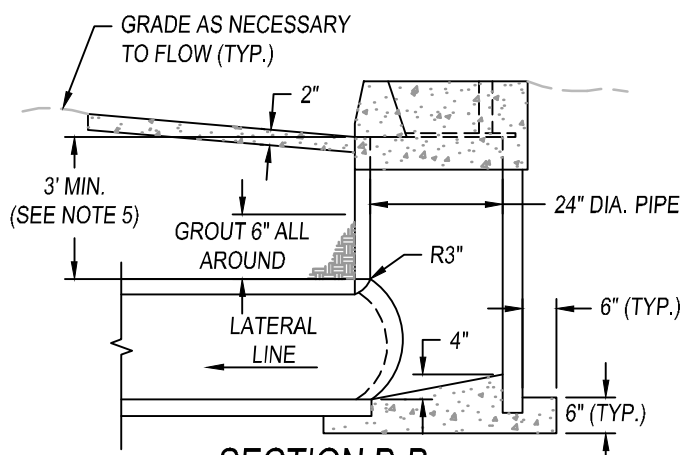

SECTION B-B

NOTES:

1. 24" CONCRETE RISER PIPE SHALL BE ASTM C-118 OR BETTER.
2. BREAK OUT OPENING IN RISER PIPE TO FIT LATERAL. CUT LATERAL TO FIT CURVATURE OF RISER. FILL JOINT SPACE WITH MORTAR.
3. FLOOR OF INLET SHALL SLOPE AS SHOWN, WITH STEEL TROWEL FINISH.
4. COST OF A.C. GUTTER PAN, DIKES, OBJECT MARKER, AND GRADING AROUND INLET TO BE INCLUDED IN THE INLET PRICE.
5. PIPE MIN. DEPTH MAY BE ADJUSTED BY THE DESIGNER OR ENGINEER. MAY REQUIRE PIPE CLASS CHANGE OR SPECIAL BACKFILL.
6. CURB SHALL BE OF SUFFICIENT LENGTH TO TRANSITION TO NATIVE GRADE. 2 FT. MIN.



CITY COUNCIL APPROVAL: 01/24/2023
 APPROVED BY CITY ENGINEER
 APPROVED BY PUBLIC WORKS DIRECTOR

TYPE 'E' INLET - TEMPORARY WITH CURB FACE OPENING
PUBLIC IMPROVEMENT STANDARDS

SD-7		
REVISIONS		
NAME	BY	DATE

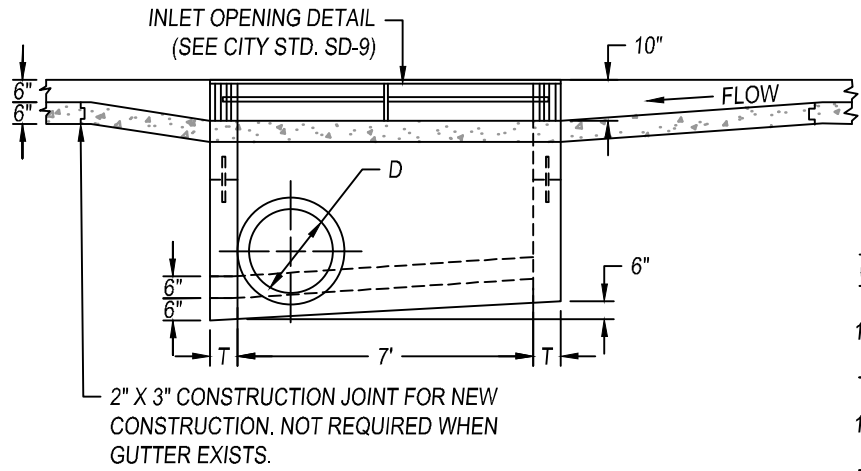

SECTION B-B

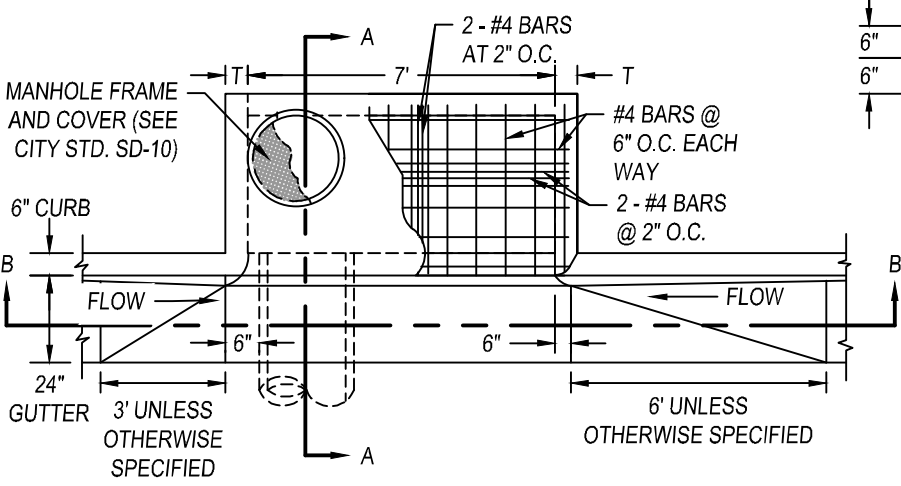

PLAN

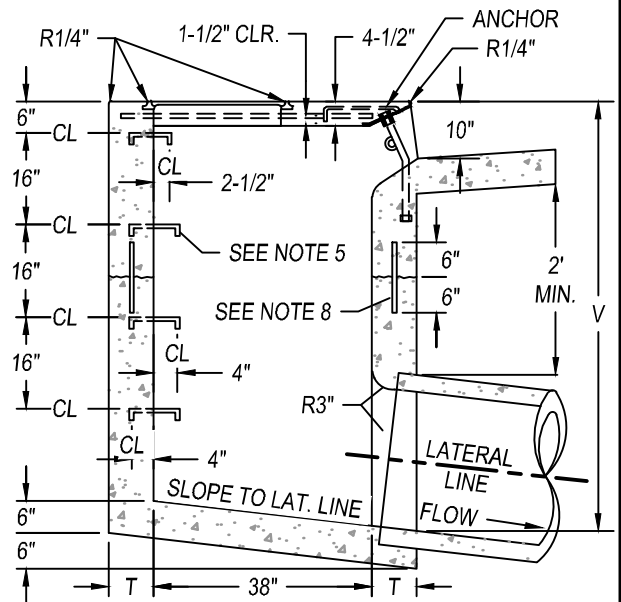

SECTION A-A

NOTES:

1. DIMENSIONS UNLESS OTHERWISE SPECIFIED.
V = SHALL BE SHOWN ON THE PLANS.
T = 6" IF V IS 4' OR LESS
T = 8" IF V IS LESS THAN 8' AND MORE THAN 4'
T = 10" IF V IS 8' OR MORE.
D = 24" UNLESS OTHERWISE SPECIFIED.
2. STRUCTURAL CONCRETE SHALL BE CLASS "A" P.C.C. (6 SACK).
3. THE REINFORCING STEEL SHALL BE NUMBER 4 DEFORMED BARS. CLEARANCE SHALL BE 1-1/2" FROM THE BOTTOM OF THE SLAB.
4. THE SURFACE OF ALL EXPOSED CONCRETE SHALL CONFORM TO SLOPE, GRADE, COLOR, FINISH, AND SCORING IN THE EXISTING OR PROPOSED CURB AND WALK ADJACENT TO THE INLET. THE INLET FLOOR SHALL BE GIVEN A TIGHT WOOD FLOAT FINISH. CURVATURE OF THE LIP AND SIDEWALLS AT THE GUTTER OPENING SHALL NOT BE MADE BY PLASTERING. THE OUTLET PIPE SHALL BE TRIMMED TO FINAL SHAPE AND LENGTH BEFORE THE CONCRETE IS POURED.

STEPS:

1. 3/4" PLAIN ROUND GALVANIZED STEEL STEPS SHALL BE INSTALLED 16" APART WHEN V EXCEEDS 4'-6". THE TOP STEP SHALL BE 6" BELOW THE TOP SURFACE AND SHALL BE 2-1/2" CLEAR FROM THE WALL. ALL OTHER STEPS SHALL BE 4" CLEAR FROM THE WALL. ONLY ONE STEP 12" FROM BOTTOM SHALL BE INSTALLED IF V IS 4'-6" OR LESS. ALL STEPS SHALL BE ANCHORED NOT LESS THAN 4" INTO THE WALL OF THE INLET.
2. CURB, GUTTER, AND LOCAL DEPRESSIONS SHALL BE CLASS "A" OR CLASS "B" CONCRETE.
3. CURB AND GUTTER SHALL BE CONSTRUCTED OR RECONSTRUCTED ON EACH SIDE OF THE BOX AS INDICATED ON THE PLANS, AND COST THEREOF SHALL BE INCLUDED IN PRICE OF INLET.
4. IF INLET IS CONSTRUCTED IN A TWO STAGE POUR, PROVIDE A ROUGHENED CONSTRUCTION JOINT AND PLACE 1 - #4 BARS 12" LONG IN EACH OF THE FOUR WALLS. AS SHOWN.



CITY COUNCIL APPROVAL: 01/24/2023
 APPROVED BY CITY ENGINEER
 APPROVED BY PUBLIC WORKS DIRECTOR

TYPE 'E' & 'G' 7" CURB INLET

PUBLIC IMPROVEMENT STANDARDS

SD-8		
REVISIONS		
NAME	BY	DATE

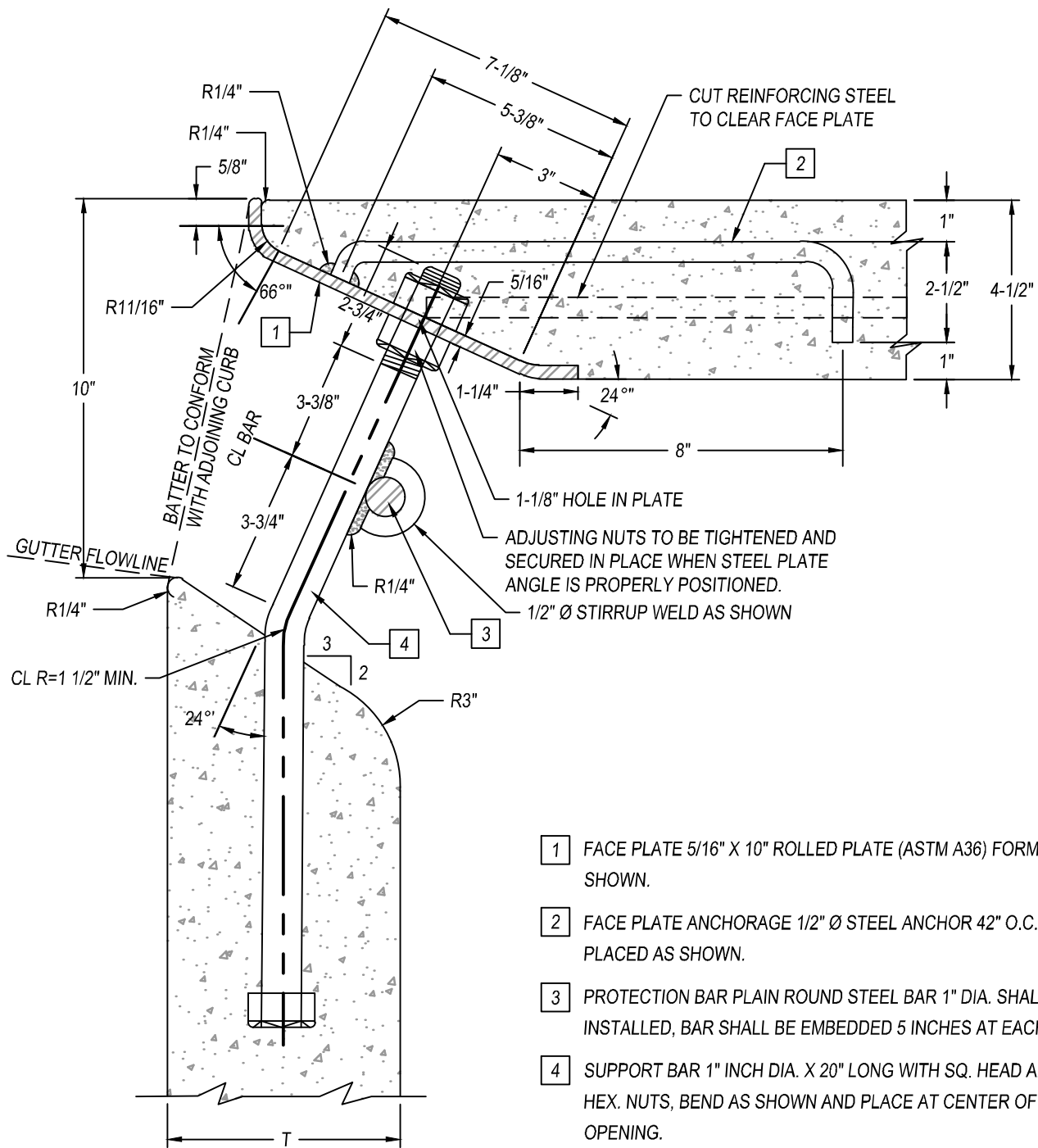

- 1 FACE PLATE 5/16" X 10" ROLLED PLATE (ASTM A36) FORMED AS SHOWN.
- 2 FACE PLATE ANCHORAGE 1/2" Ø STEEL ANCHOR 42" O.C. MAX. PLACED AS SHOWN.
- 3 PROTECTION BAR PLAIN ROUND STEEL BAR 1" DIA. SHALL BE INSTALLED, BAR SHALL BE EMBEDDED 5 INCHES AT EACH END.
- 4 SUPPORT BAR 1" INCH DIA. X 20" LONG WITH SQ. HEAD AND HEX. NUTS, BEND AS SHOWN AND PLACE AT CENTER OF INLET OPENING.

NOTE:

- 1. ALL EXPOSED METAL PARTS SHALL BE GALVANIZED.



CITY COUNCIL APPROVAL: 01/24/2023

APPROVED BY CITY ENGINEER

APPROVED BY PUBLIC WORKS DIRECTOR

**TYPE 'E' & 'G' INLET
OPENING DETAIL**

PUBLIC IMPROVEMENT STANDARDS

SD-9

REVISIONS

NAME	BY	DATE

TOP OF MANHOLE FRAME AND COVER

TOTAL WT. = 130 LBS.

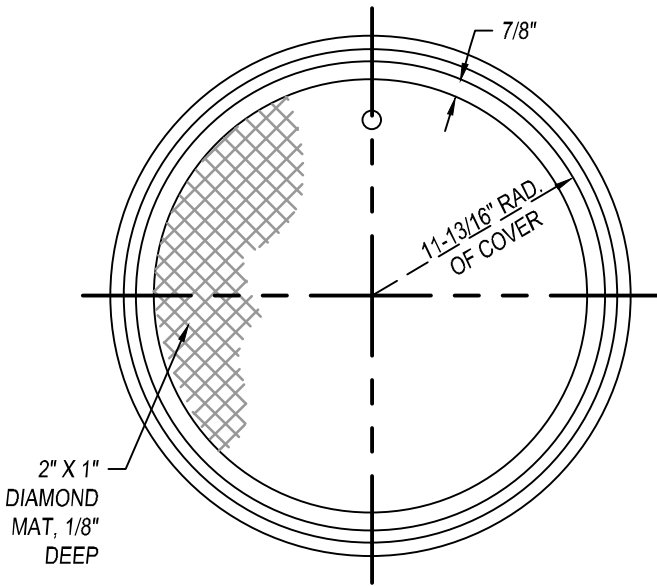

CROSS SECTION THRU FRAME AND COVER

BOTTOM OF MANHOLE COVER

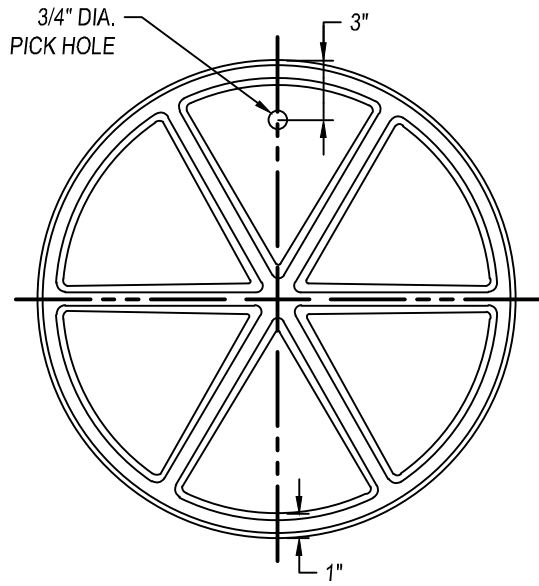

CROSS SECTION THRU RIM AT MID RADIUS

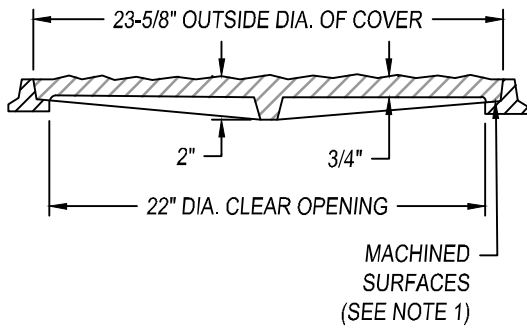

CROSS SECTION THRU RIM

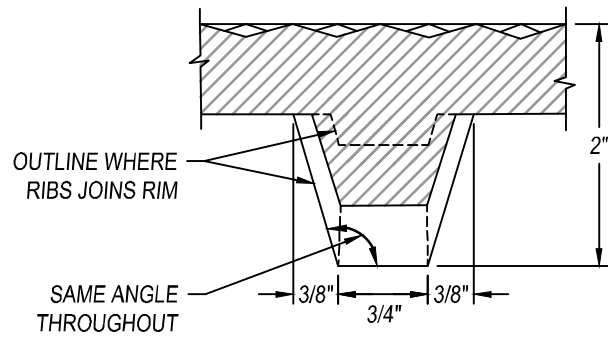

NOTE:

1. FRAME AND COVER SHALL BE GRAY CAST IRON CONFORMING TO THE LATEST A.S.T.M. STANDARD A 48, CLASS 30 OR BETTER GALVANIZE PER A.S.T.M. A385.

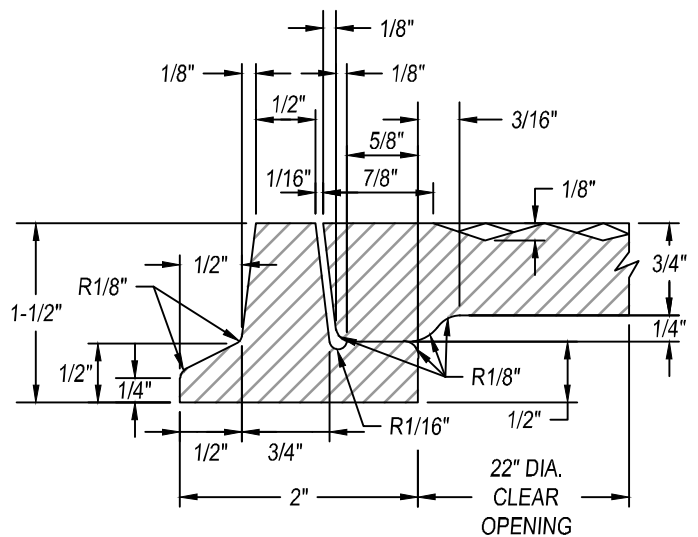

CITY COUNCIL APPROVAL: 01/24/2023

APPROVED BY CITY ENGINEER
APPROVED BY PUBLIC WORKS DIRECTOR

MANHOLE FRAME AND COVER FOR
TYPE 'E' & 'G' INLET
PUBLIC IMPROVEMENT STANDARDS

SD-10

REVISIONS		
NAME	BY	DATE

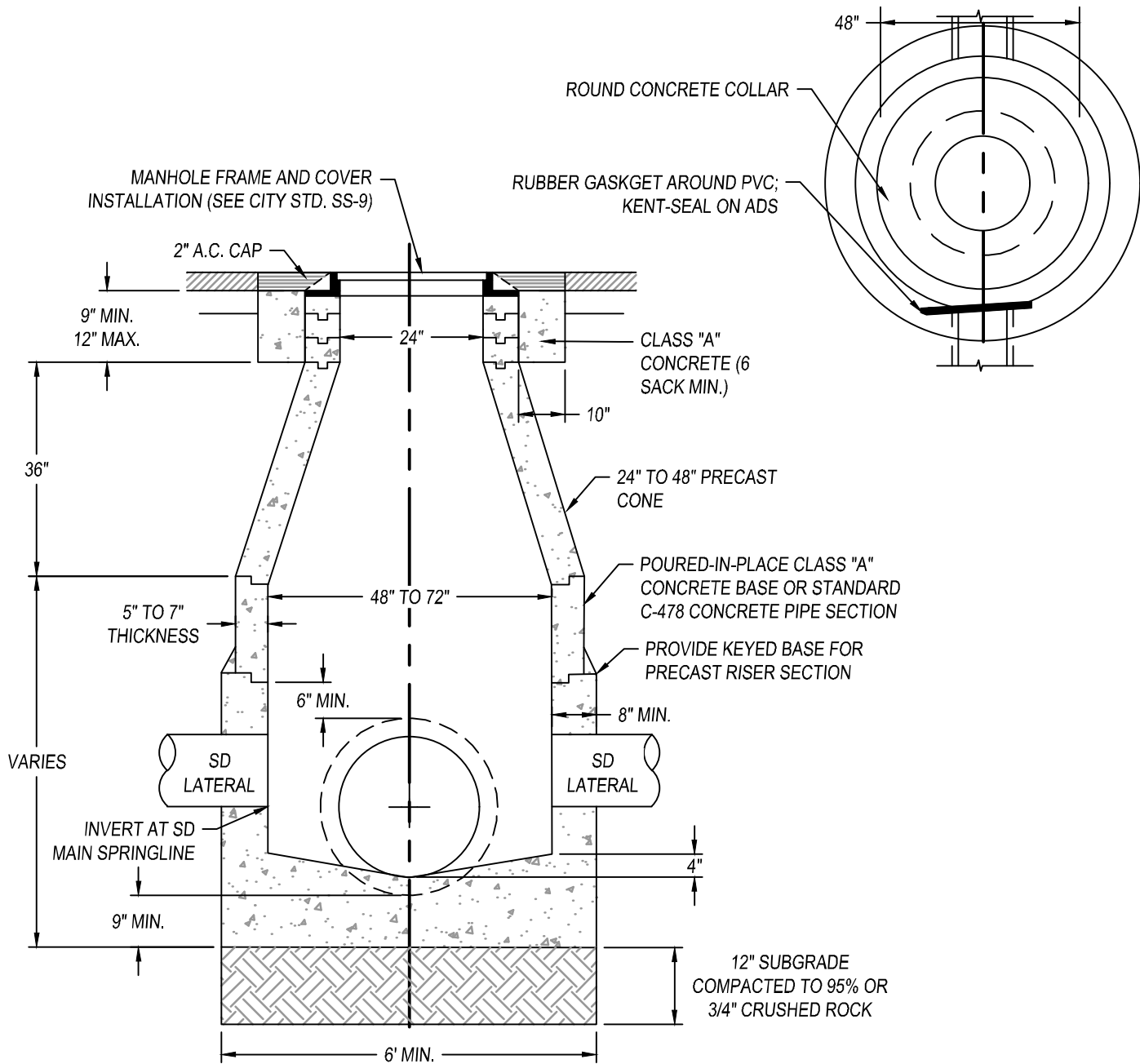

NOTES:

1. ALL CONCRETE SHALL BE CLASS "A" (6 SACK MIN.).
2. CONCRETE CONE AND GRADE RINGS SHALL BE PRECAST REINFORCED AS PER ASTM C-478.
3. GROUT AND BAND ALL PIPE JOINTS. "KENT" SEAL NO. 2 OR APPROVED EQUAL SHALL BE APPLIED BETWEEN EACH JOINT.
4. GROUT MIXTURE SHALL BE 1:2 CEMENT TO SAND.
5. WHERE MANHOLES ARE NOT IN STREETS OR TRAVEL WAYS, PLACE TOP 12" ABOVE EXISTING GROUND WITH A 24" CONCRETE RING UNLESS OTHERWISE SHOWN ON THE PLANS.
6. IF LARGEST PIPE SIZE IS 24" OR LARGER, A 72" DIAMETER MANHOLE IS REQUIRED.
7. WHEN ADJUSTING A MANHOLE, REFER TO CITY STD. SS-9.
8. NO FLOODING OR JETTING COMPACTION.
9. MAXIMUM DISTANCE BETWEEN MANHOLES SHALL BE 400'.
10. STORM DRAIN LATERALS 6" AND LARGER CONNECTED TO A MAIN REQUIRE A STORM DRAIN MANHOLE.



CITY COUNCIL APPROVAL: 01/24/2023

[Signature]
APPROVED BY CITY ENGINEER

[Signature]
APPROVED BY PUBLIC WORKS DIRECTOR

STORM DRAIN MANHOLE

PUBLIC IMPROVEMENT STANDARDS

SD-11		
REVISIONS		
NAME	BY	DATE

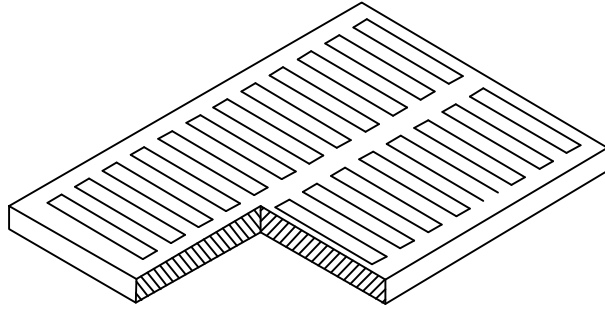

LIGHT DUTY CAST IRON

CATCH BASIN NO.	I.D. CATCH BASIN	FRAME AND GRATE NO.	APPROX. WEIGHT PER SET
U21	2'X2'	71C420	125
U23	2'X2'	71C420	125
U32	2'X3'	71C430	180
48% OPEN FLOW AREA			

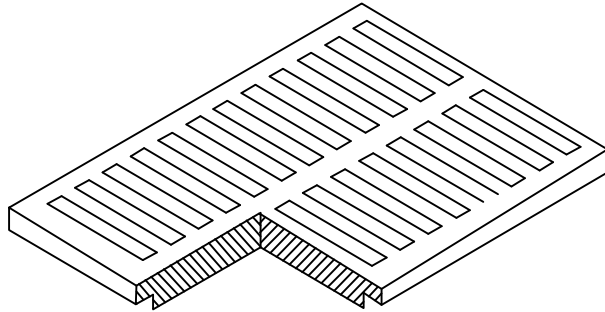

HEAVY DUTY CAST IRON

CATCH BASIN NO.	I.D. CATCH BASIN	FRAME AND GRATE NO.	APPROX. WEIGHT PER SET
U21	2'X2'	71C422	230
U23	2'X2'	71C422	230
U32	2'X3'	71C432	180
41% OPEN FLOW AREA			

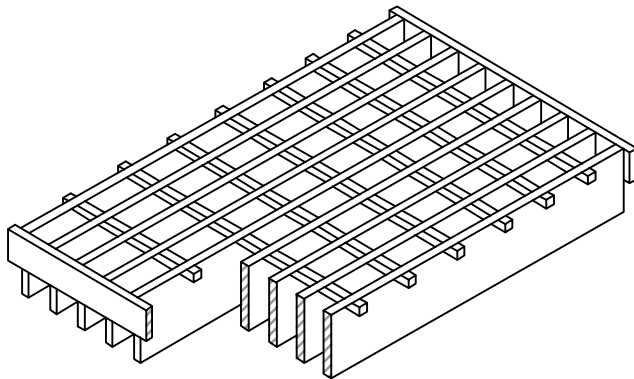

WELDED STEEL GRATES WITH CROSS BARS

CATCH BASIN NO.	I.D. CATCH BASIN	FRAME AND GRATE NO.	APPROX. WEIGHT PER SET
U21	2'X2'	71W422	165
U23	2'X2'	71W422	165
U32	2'X3'	71W432	195
U36	2'X4'	71C442	270
U43	3'X3'	71C452	295
U52	3'X4'	71C462	390 2PC
77% OPEN FLOW AREA			

NOTE:

1. ALL GRATES WITHIN AN ADA DEDICATED PATH OF TRAVEL SHOULD BE AN ADA APPROVED GRATE PER THE LATEST EDITION OF THE CBC.



CITY COUNCIL APPROVAL: 01/24/2023

 APPROVED BY CITY ENGINEER

 APPROVED BY PUBLIC WORKS DIRECTOR

CATCH BASIN GRATE

PUBLIC IMPROVEMENT STANDARDS

SD-12

REVISIONS

NAME	BY	DATE

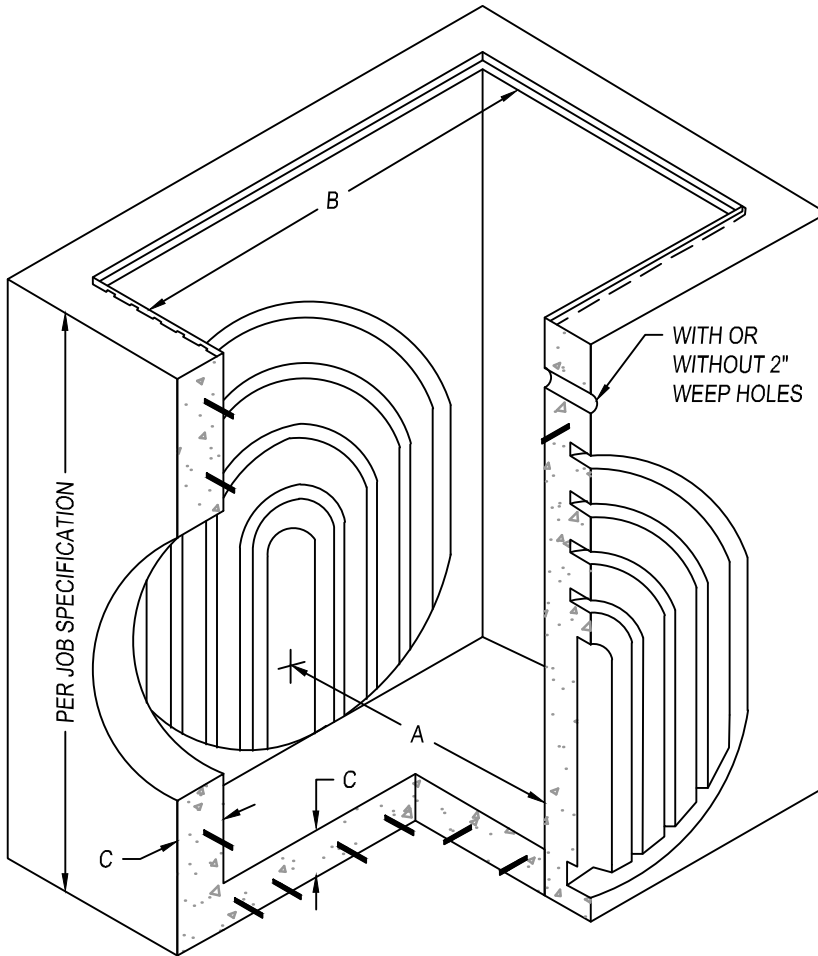

PRODUCT NUMBER	DIMENSIONS		
	A	B	C
U21	2'	2'	4'
U23	2'	2'	6'
U32	2'	3'	6'
U36	2'	4'	5'
U43	3'	3'	6'
U52	3'	4'	6'

NOTES:

1. STANDARD GRADE RINGS ARE AVAILABLE IN 6" INCREMENTS UP TO 4' HIGH.
2. CUSTOMER SPECIFIED TOP EDGE CHOICES CAST INTO CATCH BASIN OR GRADE RINGS (SEE CITY STD. SD-14).

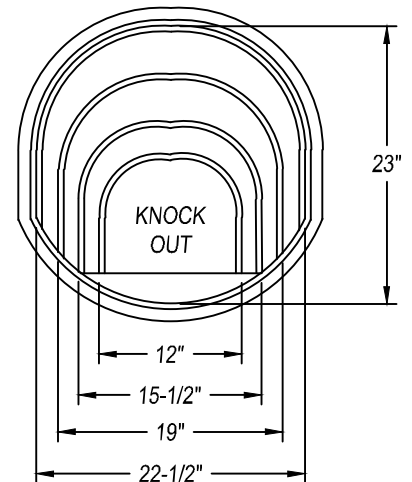
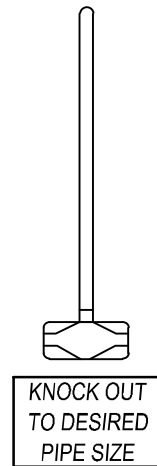
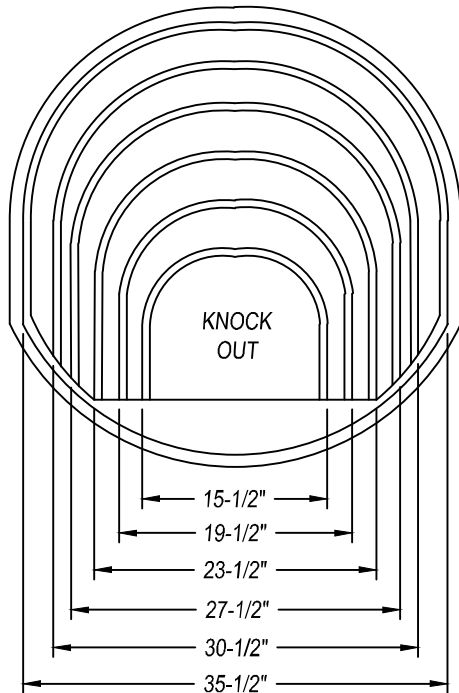

CITY COUNCIL APPROVAL: 01/24/2023

APPROVED BY CITY ENGINEER

APPROVED BY PUBLIC WORKS DIRECTOR

"CHRISTY" U SERIES CATCH BASINS

PUBLIC IMPROVEMENT STANDARDS

SD-13

REVISIONS

NAME	BY	DATE

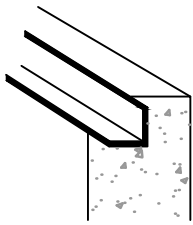

CAST-IN GALVANIZED FRAME FOR GRATES 1-1/2" X 1-1/2" ANGLE IRON WITH ANCHOR BOLTS

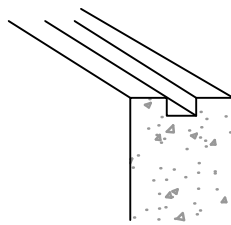

GROOVED TO RECEIVE TONGUE OF GRADE RINGS, CURB INLETS, ETC.

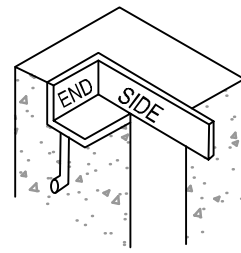

CAST-IN GALVANIZED FRAME FOR STATE TYPE GRATES 4"X3"X1/4" ANGLE IRON ENDS WITH ANCHOR BOLTS 3-1/2"X1/4" SIDE BARS

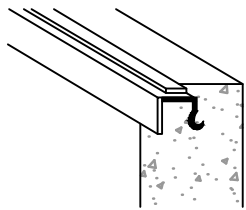

CAST-IN GALVANIZED FRAME FOR 1/4" STEEL LIDS WITH BOLT DOWN PROVISIONS

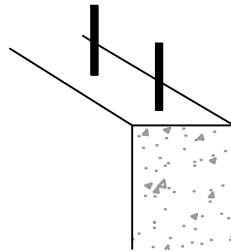

6" EXPOSED REBAR TO ALLOW JOB SITE POURING OF SPECIAL CURB SHAPES AT GRADE LEVEL, ETC.

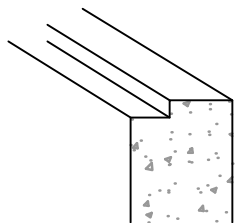

RECESSED FOR 1/4" STEEL LIDS WITH BOLT DOWN PROVISIONS

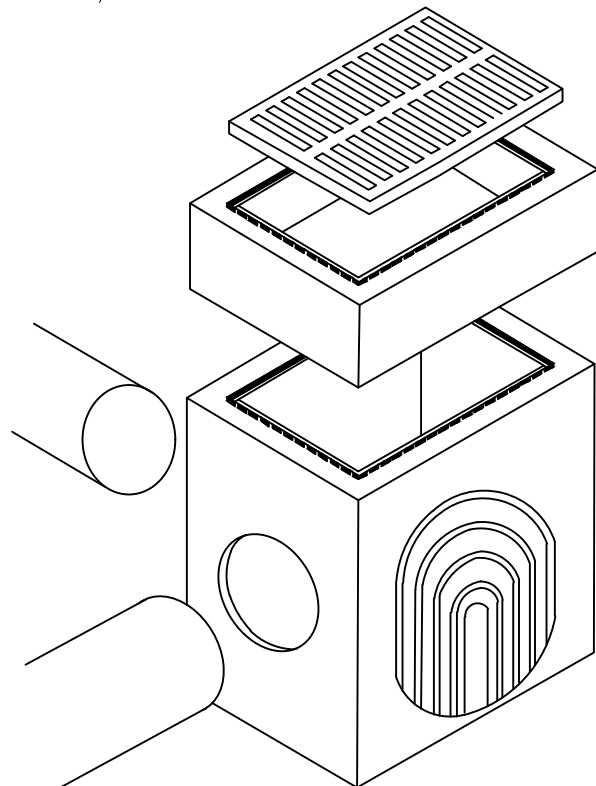

NOTES:

1. OPENINGS, LOCATIONS AND SIZES TO JOB SPECIFICATIONS.
2. WITH OR WITHOUT BOTTOM.
3. PROGRESSIVE WEBBED KNOCK-OUTS PROVIDE MAXIMUM FLEXIBILITY PERMITTING PIPE OF ANY SIZE TO BE NEATLY AND QUICKLY GROUTED IN AT JOB SITE.
4. STANDARD TONGUE AND GROOVE GRADE RINGS ARE AVAILABLE IN 6" INCREMENTS UP TO 4' HIGH.
5. ALL REINFORCING STEEL MEETS ASTM SPECIFICATIONS AS REQUIRED.
6. CITY APPROVAL REQUIRED FOR APPLICATION.



CITY COUNCIL APPROVAL: 01/24/2023

APPROVED BY CITY ENGINEER
 APPROVED BY PUBLIC WORKS DIRECTOR

TOP EDGE CHOICES FOR CATCH BASIN AND/OR GRATE RING

PUBLIC IMPROVEMENT STANDARDS

SD-14

REVISIONS		
NAME	BY	DATE

FOR OUTFALL CAGE
STRUCTURE, SEE FENCE
CAGE FOR OUTFALL
STRUCTURE TYPE A
STANDARD DRAWING.

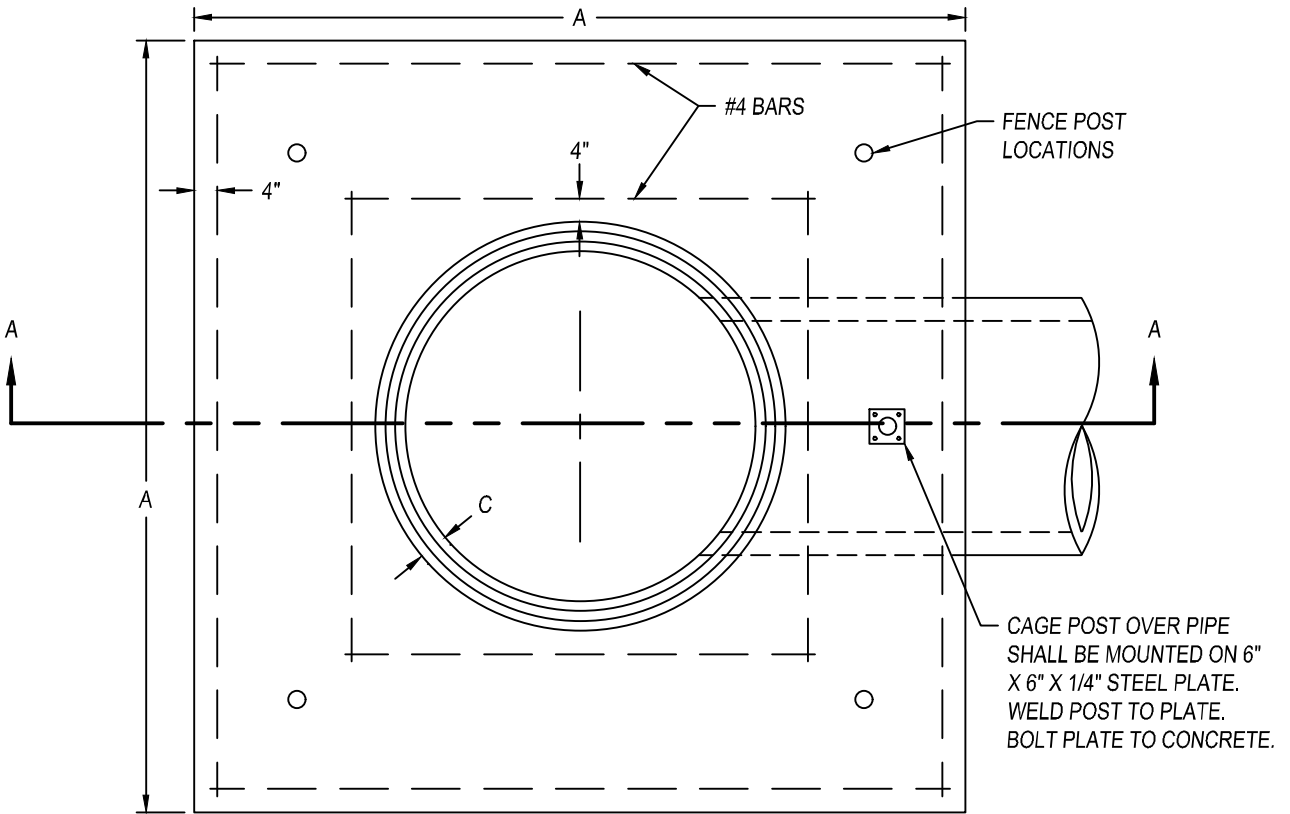
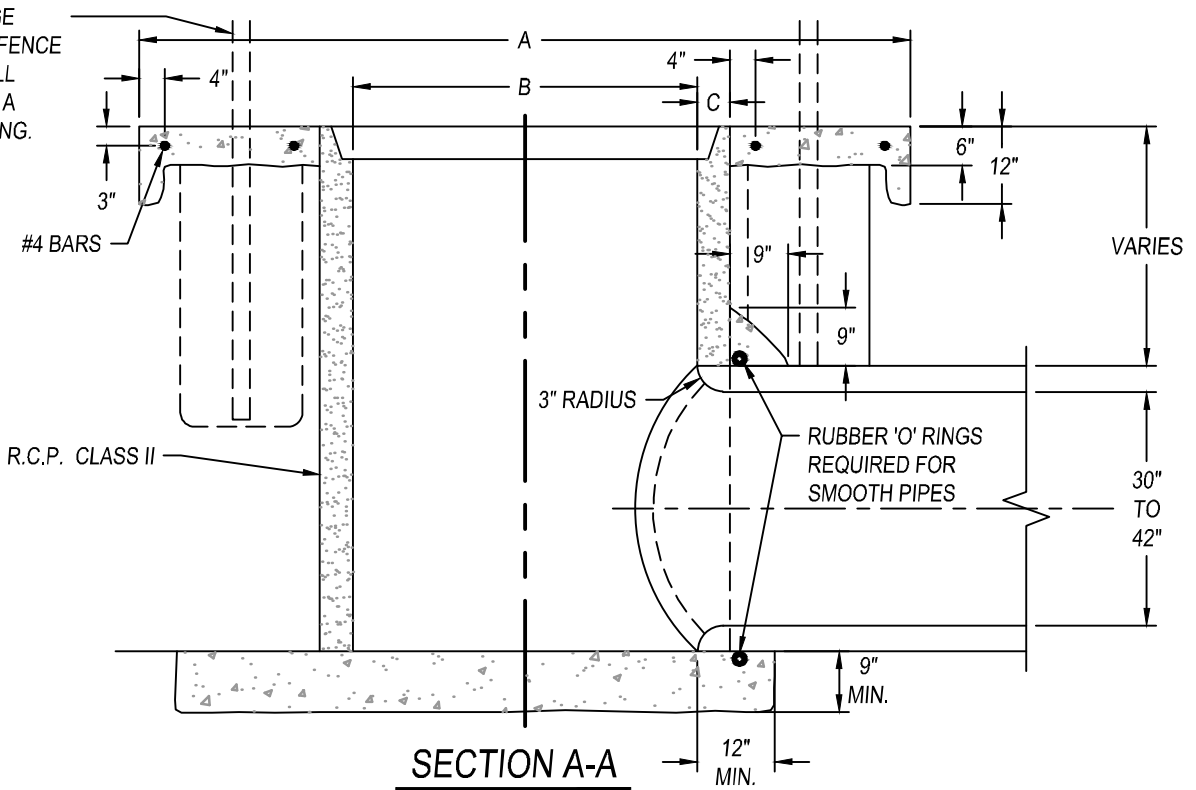

NOTES:

PLAN

- FOR DIMENSIONS SEE DESIGN TABLE FOR OUTFALL STRUCTURE TYPE A STANDARD DRAWING.



CITY COUNCIL APPROVAL: 01/24/2023
 APPROVED BY CITY ENGINEER
 APPROVED BY PUBLIC WORKS DIRECTOR

OUTFALL STRUCTURE TYPE A

PUBLIC IMPROVEMENT STANDARDS

SD-15

REVISIONS		
NAME	BY	DATE

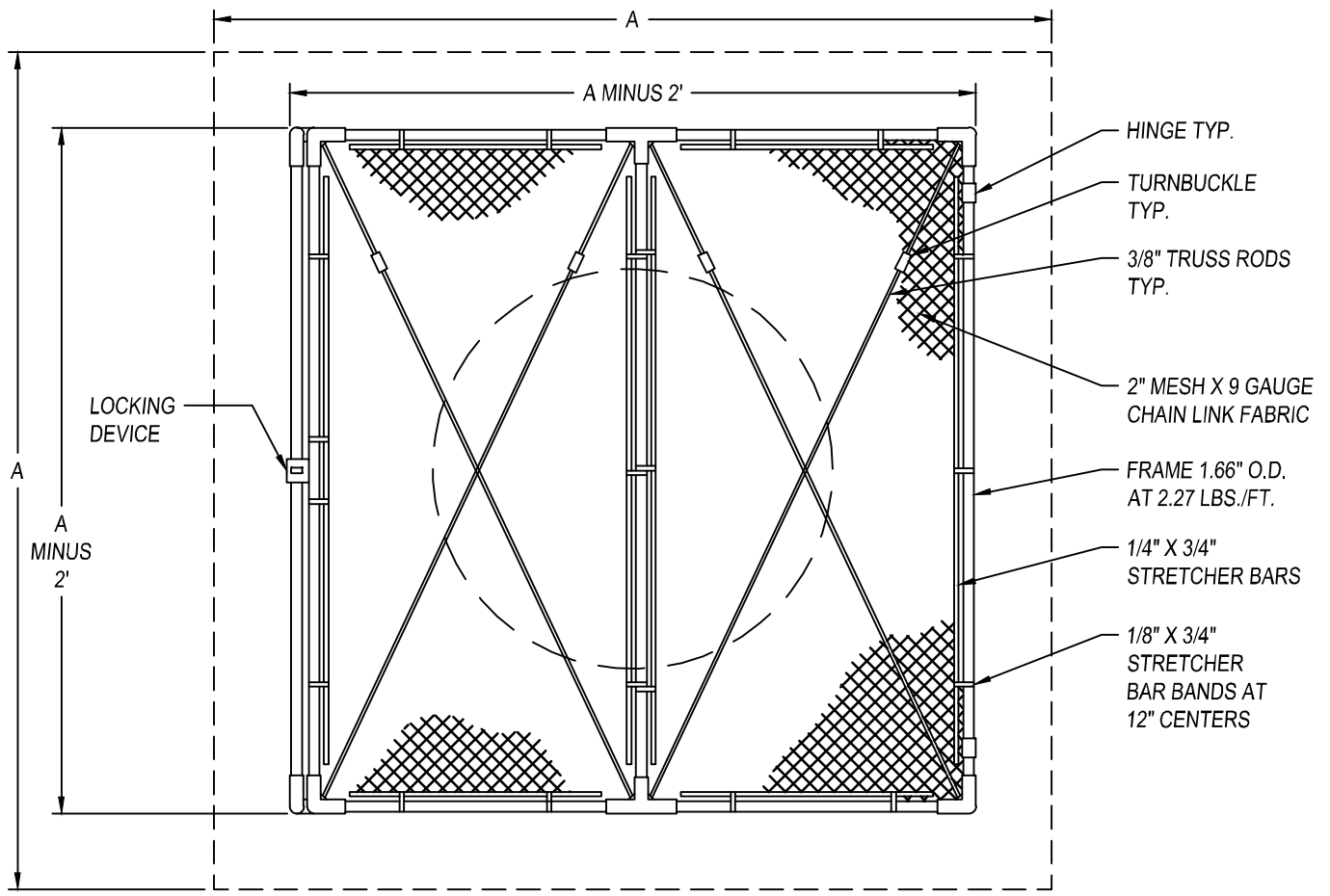
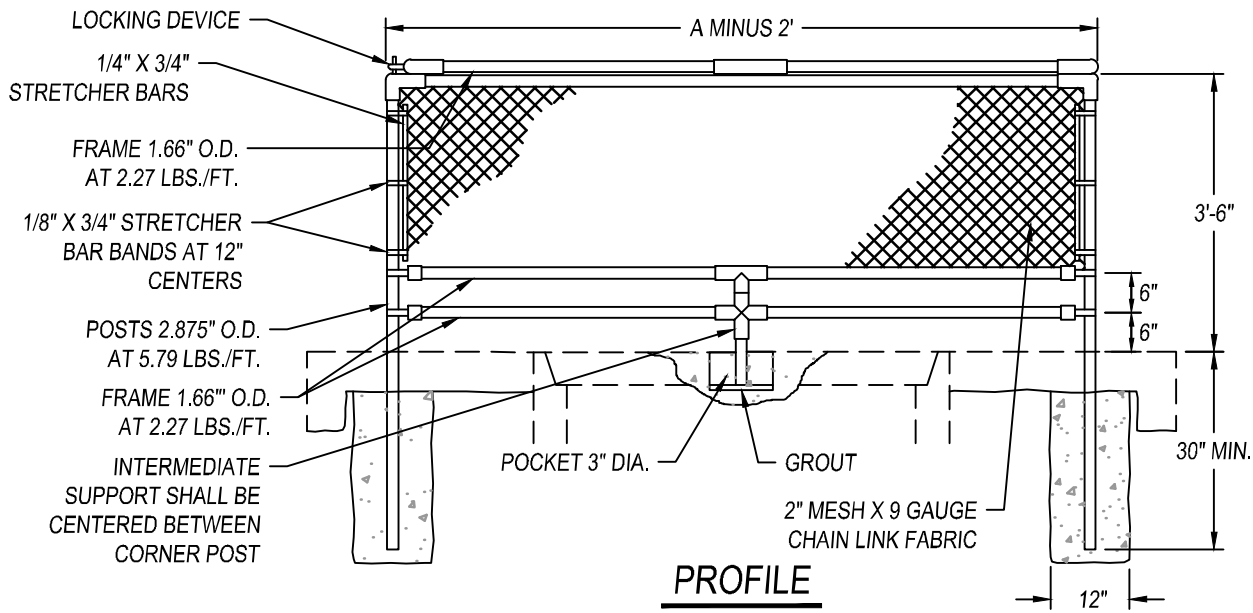

NOTES:

1. LOCKING DEVICE SHALL BE APPROVED BY THE CITY ENGINEER.
2. FOR DIMENSIONS, SEE DESIGN TABLE FOR OUTFALL STRUCTURE TYPE A STANDARD DRAWING.



CITY COUNCIL APPROVAL: 01/24/2023

APPROVED BY CITY ENGINEER

APPROVED BY PUBLIC WORKS DIRECTOR

FENCE CAGE FOR OUTFALL STRUCTURE TYPE A

PUBLIC IMPROVEMENT STANDARDS

SD-16		
REVISIONS		
NAME	BY	DATE

TYPE	MAX. PIPE SIZE	DESIGN (C.F.S.)	A	B	C
A	30"	12-16	8'-0"	42"	3 1/2"
A	36"	16-21	9'-0"	48"	4"
A	42"	21-29	10'-0"	54"	4 1/2"

DESIGN TABLE

TYPE A

NOTES:

1. ALL CONCRETE SHALL BE CLASS 3 CONCRETE.
2. REINFORCING BARS SHALL BE DEFORMED STEEL BARS AND SHALL BE GRADE 40 MINIMUM. REINFORCING BARS SHALL BE FREE OF RUST OR DIRT AND SHALL BE THOROUGHLY CLEANED BEFORE PLACEMENT.
3. REINFORCING BARS SHALL HAVE A MINIMUM OF 2" OF CLEAR COVERAGE.



CITY COUNCIL APPROVAL: 01/24/2023

[Signature]
APPROVED BY CITY ENGINEER

[Signature]
APPROVED BY PUBLIC WORKS DIRECTOR

**DESIGN TABLE FOR OUTFALL
STRUCTURE TYPE A**

PUBLIC IMPROVEMENT STANDARDS

SD-17		
REVISIONS		
NAME	BY	DATE

FOR OUTFALL CAGE
STRUCTURES, SEE
FENCE CAGE FOR
OUTFALL STRUCTURE
TYPE B STANDARD
DRAWING

N - #4 BARS

M - #4 BARS
EQUALLY SPACED

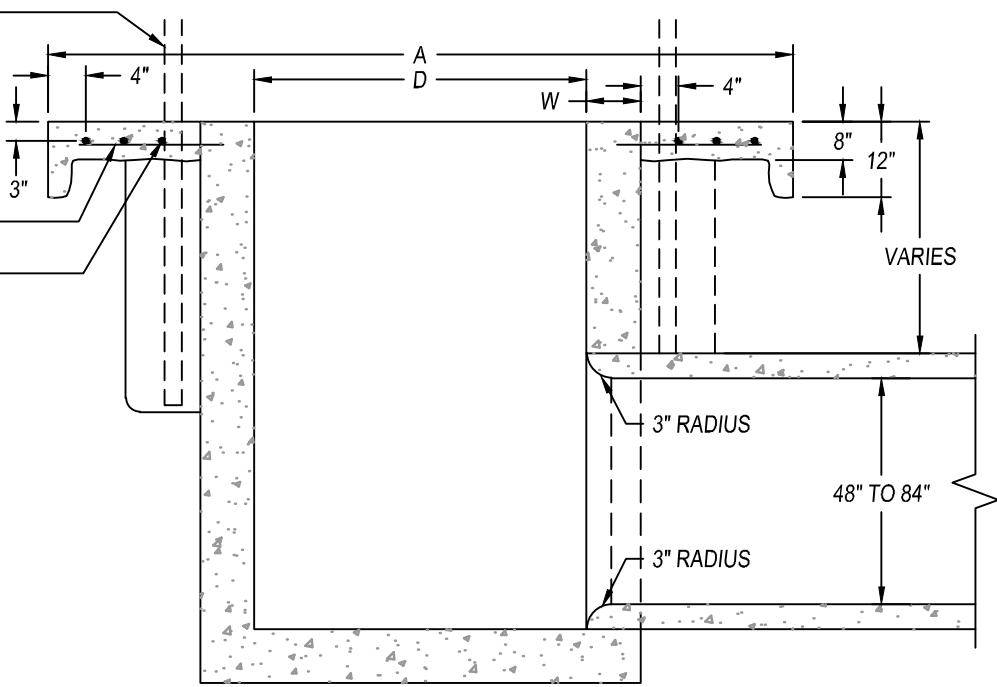

SECTION A-A

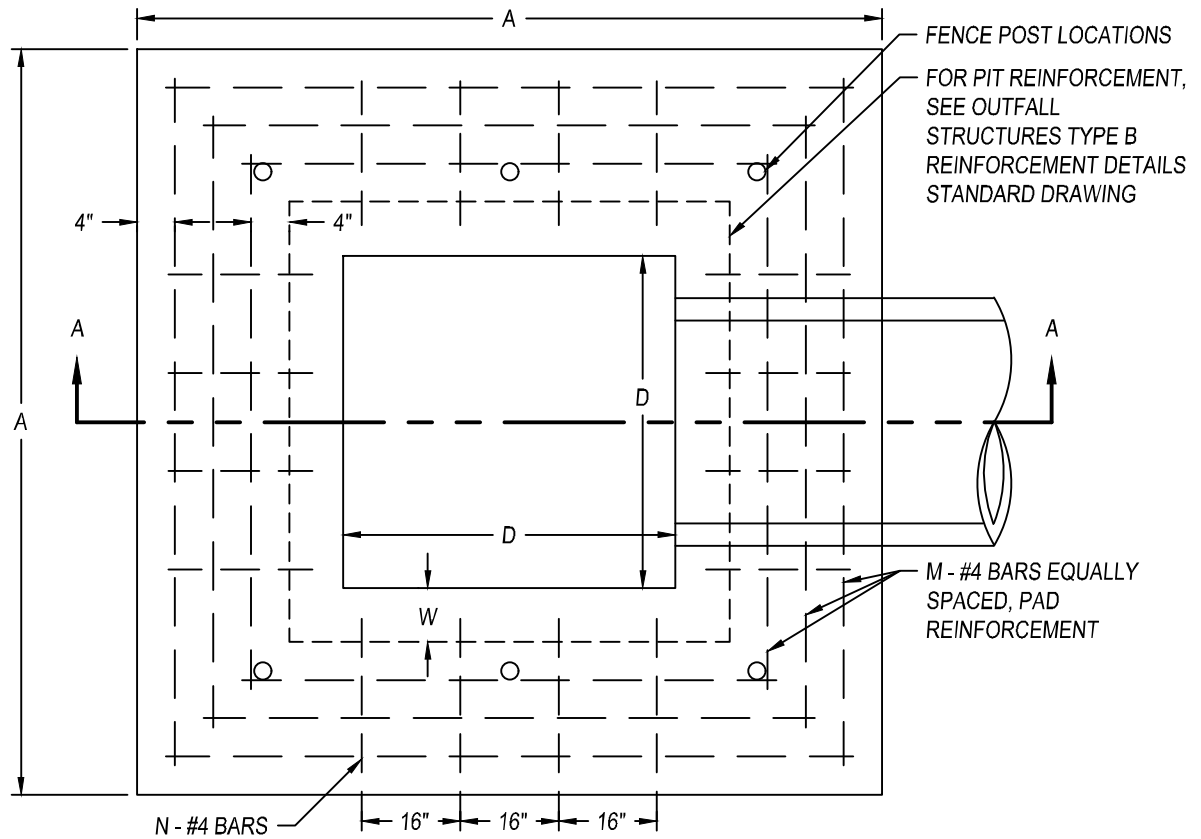

PLAN

NOTES:

- 1. FOR DIMENSIONS SEE DESIGN TABLE FOR OUTFALL STRUCTURE TYPE A STANDARD DRAWING.



CITY COUNCIL APPROVAL: 01/24/2023
 APPROVED BY CITY ENGINEER
 APPROVED BY PUBLIC WORKS DIRECTOR

OUTFALL STRUCTURE TYPE B

PUBLIC IMPROVEMENT STANDARDS

SD-18

REVISIONS		
NAME	BY	DATE

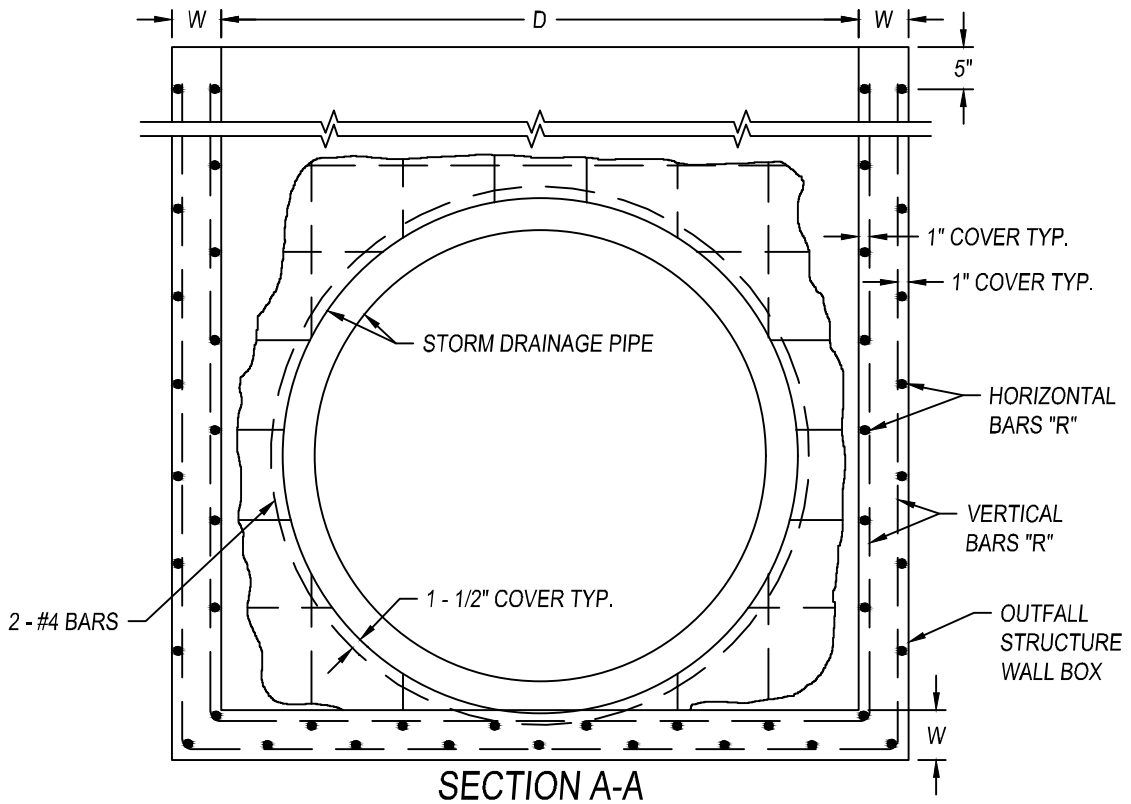

SECTION A-A

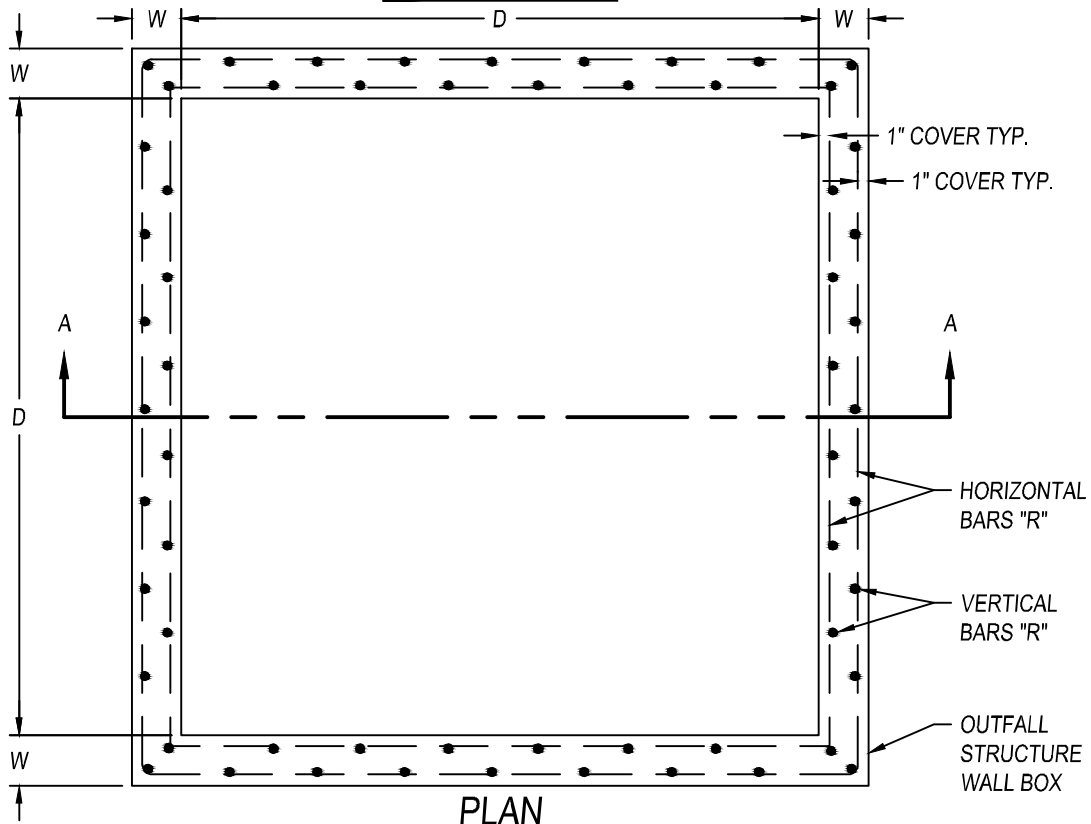

PLAN

NOTES:

1. FOR DIMENSIONS AND REBAR SIZE AND SPACING, SEE DESIGN TABLE FOR OUTFALL STRUCTURE TYPE B STANDARD DRAWING.
2. ALL REINFORCEMENT SHALL CONFORM WITH THE CITY OF VISALIA STANDARD SPECIFICATIONS.



CITY COUNCIL APPROVAL: 01/24/2023
 APPROVED BY CITY ENGINEER
 APPROVED BY PUBLIC WORKS DIRECTOR

**OUTFALL STRUCTURE TYPE B
 REINFORCEMENT DETAILS
 PUBLIC IMPROVEMENT STANDARDS**

SD-19		
REVISIONS		
NAME	BY	DATE

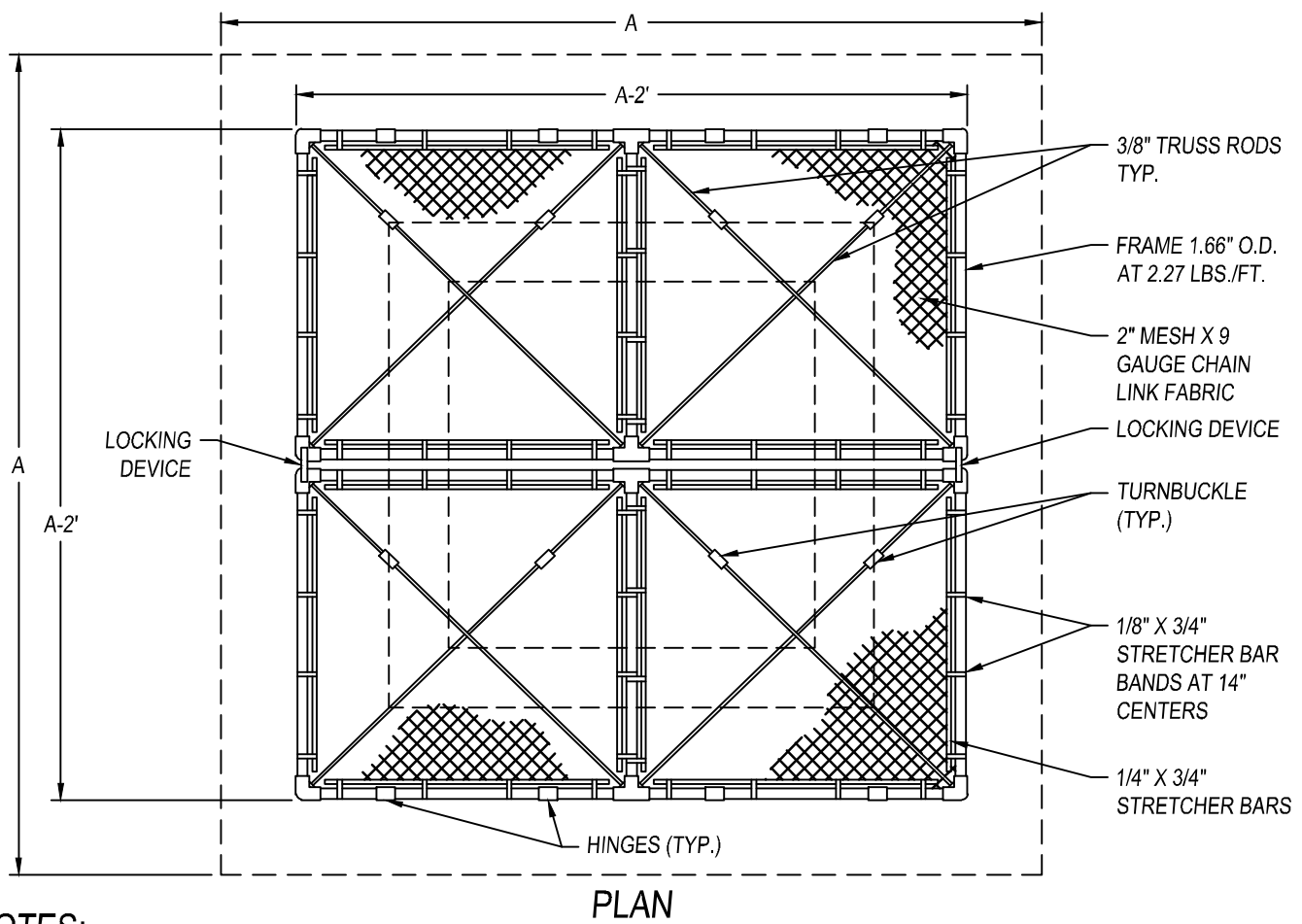
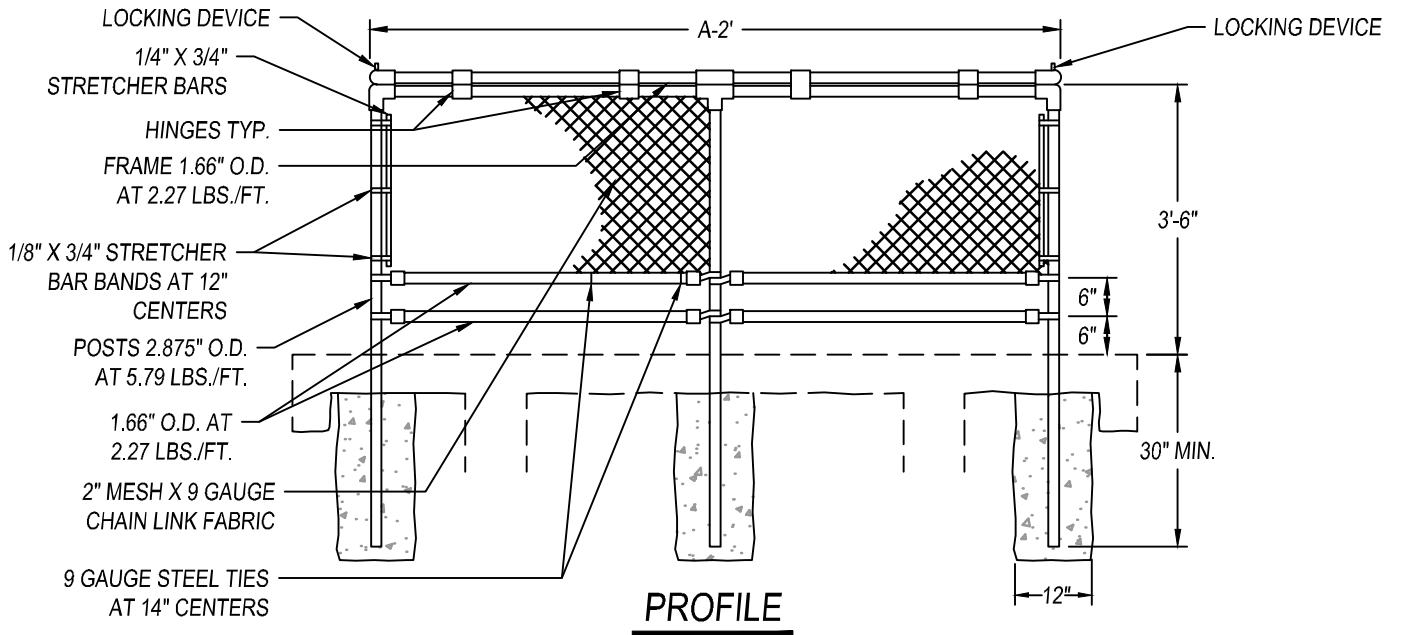

NOTES:

1. LOCKING DEVICE SHALL BE APPROVED BY THE CITY ENGINEER.
2. FOR DIMENSIONS, SEE DESIGN TABLE FOR OUTFALL STRUCTURE TYPE B STANDARD DRAWING.



CITY COUNCIL APPROVAL: 01/24/2023

APPROVED BY CITY ENGINEER

APPROVED BY PUBLIC WORKS DIRECTOR

**FENCE CAGE FOR OUTFALL
STRUCTURE TYPE B**

PUBLIC IMPROVEMENT STANDARDS

SD-20		
REVISIONS		
NAME	BY	DATE

TYPE	MAX. PIPE SIZE	DESIGN (C.F.S.)	A	D	F	M	N	W	R*
B	48"	38-50	10'-0"	5'-0"	2'-0"	2	3	8"	#4 AT 12"
B	60"	50-65	12'-0"	6'-0"	3'-0"	3	4	8"	#4 AT 12"
B	66"	65-85	14'-0"	7'-0"	3'-6"	3	5	8"	#4 AT 12"
B	72"	85-110	16'-0"	8'-0"	4'-0"	3	6	10"	#5 AT 10"
B	84"	110-140	18'-0"	9'-0"	4'-6"	4	8	10"	#5 AT 10"

DESIGN TABLE

TYPE B

NOTES:

1. ALL CONCRETE SHALL BE CLASS 3 CONCRETE.
 2. REINFORCING BARS SHALL BE DEFORMED STEEL BARS AND SHALL BE GRADE 40 MINIMUM. REINFORCING BARS SHALL BE FREE OF RUST OR DIRT AND SHALL BE THOROUGHLY CLEANED BEFORE PLACEMENT.
 3. REINFORCING BARS SHALL HAVE A MINIMUM OF 2" OF CLEAR COVERAGE.
- * REINFORCEMENT SHALL CONSIST OF A DOUBLE CURTAIN BOTH DIRECTIONS OF THE SIZE AND SPACING NOTED. SEE OUTFALL STRUCTURE TYPE B REINFORCEMENT DETAILS STANDARD DRAWING.



CITY COUNCIL APPROVAL: 01/24/2023

[Signature]
APPROVED BY CITY ENGINEER

[Signature]
APPROVED BY PUBLIC WORKS DIRECTOR

DESIGN TABLE FOR OUTFALL
STRUCTURE TYPE B

PUBLIC IMPROVEMENT STANDARDS

SD-21

REVISIONS		
NAME	BY	DATE

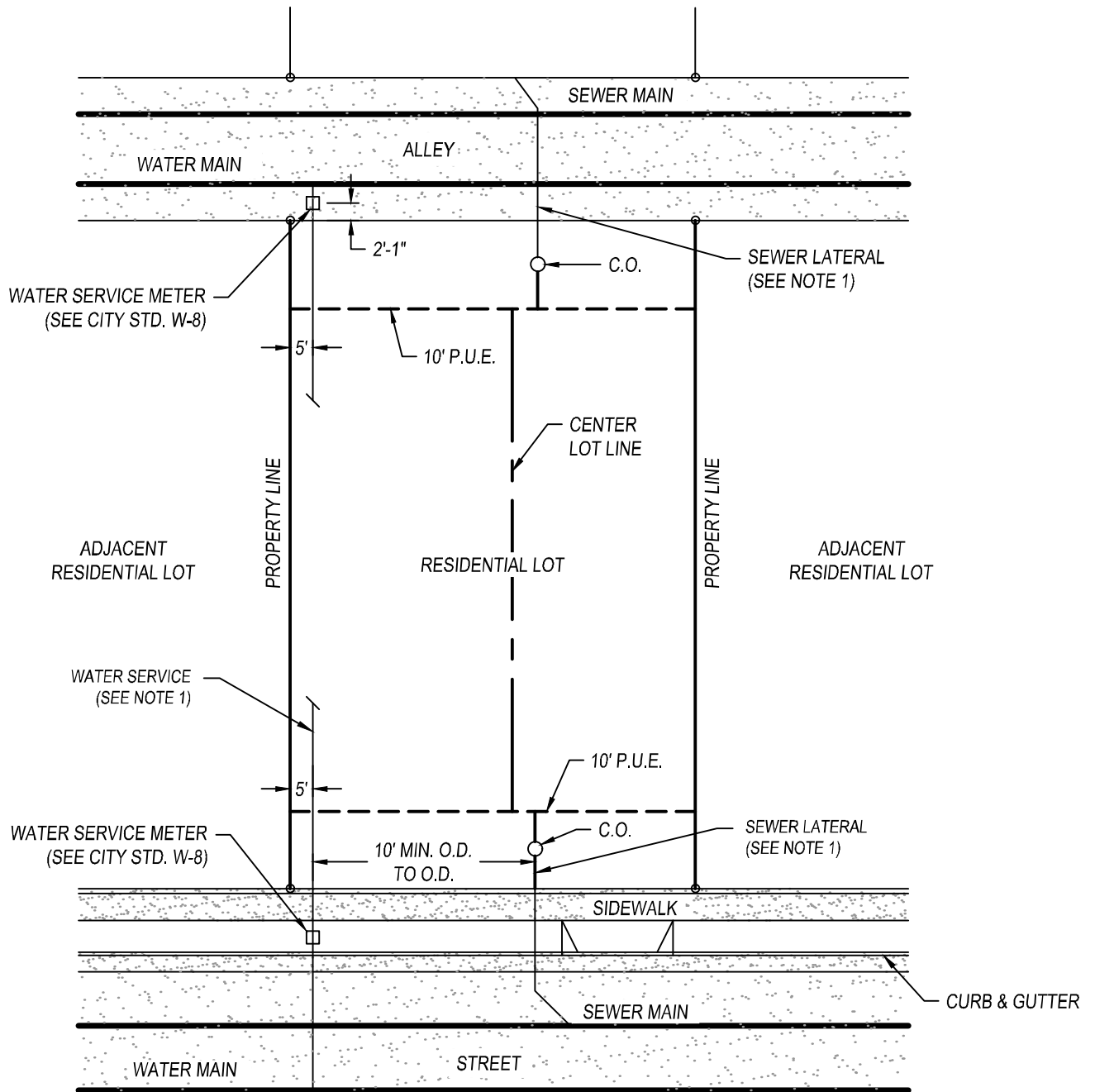

NOTES:

1. SEWER LATERAL TO BE LOCATED 5' FROM CENTER LOT LINE; WATER SERVICE TO BE LOCATED 5' FROM PROPERTY LINE. MINIMUM DISTANCE BETWEEN WATER SERVICES AND SEWER LATERALS SHALL BE 10' MIN. FROM O.D. TO O.D.
2. SEWER LATERAL ON PROPERTY WITH CLEANOUT ON BOTH STREET AND ALLEY SIDE. SEE CITY STD. SS-9.
3. ALL UTILITIES AND DRIVEWAYS SHALL BE LOCATED NEAR OPPOSING PROPERTY LINE FROM WATER METER LOCATION.
4. FOR WATER METER INSTALLATION, SEE CITY STD. W-8.
5. TWO WAY CLEANOUT AT BUILDING TO REPLACE CLEANOUT IN P.U.E.



CITY COUNCIL APPROVAL: 01/24/2023

[Signature]
APPROVED BY CITY ENGINEER

[Signature]
APPROVED BY PUBLIC WORKS DIRECTOR

**SEWER AND WATER SERVICE
PROPERTY LOCATIONS**

PUBLIC IMPROVEMENT STANDARDS

SS-1		
REVISIONS		
NAME	BY	DATE

WATER LINE AND SEWER LINE SEPARATION

A. NEW CONSTRUCTION - WHEN NEITHER WATER MAINS NOR SEWER MAINS ARE EXISTING, THE FOLLOWING SHALL APPLY WHEREVER POSSIBLE:

1. **PARALLEL MAINS** - THE HORIZONTAL SEPARATION BETWEEN PRESSURE WATER MAINS AND SANITARY SEWER MAINS SHALL BE AT LEAST 10 FEET FROM OUTSIDE OF PIPE TO OUTSIDE OF PIPE.
2. **CROSSING MAINS** - PRESSURE WATER MAINS SHALL HAVE A MIN. THREE FEET OF SEPARATION ABOVE THE SANITARY SEWER MAINS, WHERE THESE LINES MUST CROSS.
3. ALL WATER MAIN AND SEWER MAIN SEPARATIONS SHALL FOLLOW THE CALIFORNIA STATE WATER BOARDS' REQUIREMENTS.

ALTERNATIVE CONDITIONS: WHERE REQUIRED SEPARATION CANNOT BE MAINTAINED

B. ALTERNATIVE CONDITIONS - WHEN EITHER WATER MAINS OR SEWER MAINS ARE EXISTING, OR THE CONDITIONS REQUIRED IN "A" ABOVE CANNOT BE MET, THE FOLLOWING SHALL APPLY:

1. NEW SEWER MAIN AND EXISTING WATER MAIN. - CASE 1 AND 2.
2. NEW WATER MAIN AND EXISTING SEWER MAIN. - CASE 3.

PARALLEL CONSTRUCTION

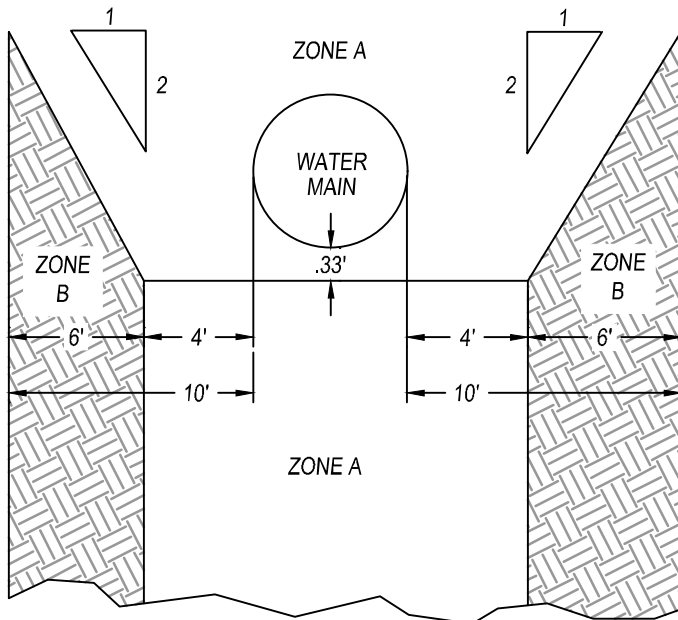

PERPENDICULAR CONSTRUCTION

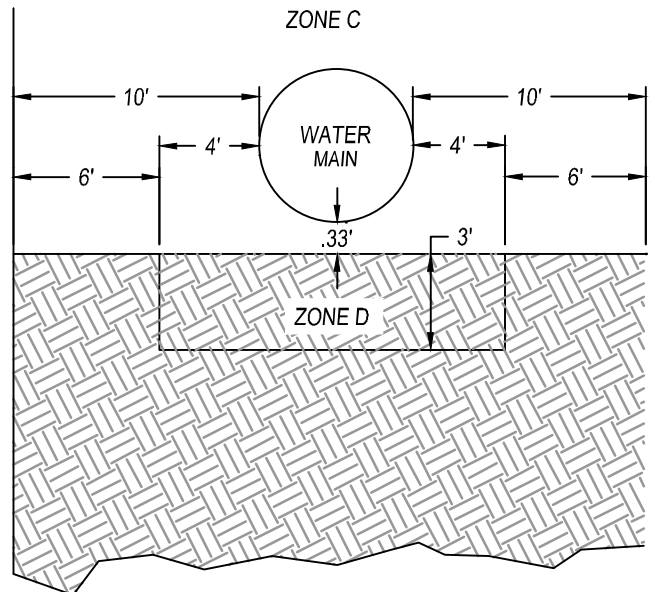

NOTES:

DIMENSIONS ARE FROM OUTSIDE OF WATER MAIN TO OUTSIDE OF SANITARY SEWER MAIN. DESCRIPTIONS OF COMPRESSION JOINTS, MECHANICAL JOINTS, AND REQUIRED CONCRETE ENCASEMENT ARE ON SHEET 2.



CITY COUNCIL APPROVAL: 01/24/2023

APPROVED BY CITY ENGINEER
APPROVED BY PUBLIC WORKS DIRECTOR

**WATER MAIN AND SANITARY SEWER
MAIN SEPARATION (SHEET 1 OF 2)**
PUBLIC IMPROVEMENT STANDARDS

SS-2

REVISIONS

NAME	BY	DATE

CASE 1 & 2: NEW SEWER MAIN AND EXISTING WATER MAIN

ZONE CONSTRUCTION LIMITATIONS AND REQUIREMENTS

- A. SEWER MAINS WILL NOT BE PERMITTED IN THIS ZONE WITHOUT SPECIAL PERMISSION FROM THE DEPARTMENT OF PUBLIC WORKS.
- B. EXTRA-STRENGTH VITRIFIED CLAY PIPE WITH COMPRESSION JOINTS; OR CONCRETE PIPE WITH REINFORCED CONCRETE COLLARS AROUND THE JOINTS, WHICH JOINTS SHALL HAVE A MINIMUM THICKNESS OF SIX INCHES ON EITHER SIDE OF THE JOINT; OR RUBBER GASKET REINFORCED CONCRETE PIPE; OR RUBBER GASKETED ASBESTOS-CEMENT PIPE; OR RUBBER GASKETED PLASTIC PIPE; OR CAST IRON PIPE WITH COMPRESSION JOINTS.
- C. OR D. CLASS 150 OR HEAVIER CAST-IRON PIPE WITH HOT DIP BITUMINOUS COATED AND APPROVED MECHANICAL JOINTS; OR ANY SEWER PIPE WITHIN A CONTINUOUS STEEL CASING, WHICH CASING SHALL HAVE A THICKNESS OF NOT LESS THAN ONE-FOURTH INCH AND WITH ALL VOIDS BETWEEN SEWER PIPE AND CASING PRESSURE GROUTED WITH SAND-CEMENT GROUT.

CASE 3: NEW WATER MAIN AND EXISTING SEWER MAIN

IF AN EXISTING SEWER MAIN IS LOCATED WITHIN ZONE A, B, C, OR D OF A NEW WATER MAIN, THE FOLLOWING SPECIAL REQUIREMENTS APPLY:

ZONE CONSTRUCTION LIMITATIONS AND REQUIREMENTS

- A. NO WATER MAINS SHALL BE CONSTRUCTED WITHOUT SPECIAL PERMISSION FROM THE DEPARTMENT OF PUBLIC WORKS.
- B. IF THE SEWER MAIN DOES NOT MEET THE ZONE B. REQUIREMENTS GIVEN ABOVE THE WATER MAIN SHALL BE OF CLASS 200 PIPE, OR APPROVED EQUAL.
- C. NO WATER MAINS SHALL BE CONSTRUCTED WITHOUT SPECIAL PERMISSION FROM THE DEPARTMENT OF PUBLIC WORKS. IF PERMISSION IS GRANTED, THE SEWER MAIN SHALL BE ENCASED WITH REINFORCED CONCRETE AND THE WATER MAIN SHALL BE OF CLASS 200 PIPE, OR APPROVED EQUAL.
- D. THE SEWER MAIN SHALL BE ENCASED WITH REINFORCED CONCRETE.

DESCRIPTIONS:

1. COMPRESSION JOINTS ARE RUBBER RING OR GASKET JOINTS.
2. MECHANICAL JOINTS ARE BOLTED JOINTS.
3. ACCEPTABLE REINFORCED CONCRETE ENCASEMENT IS AS TO THE RIGHT:
4. CONCRETE SHALL BE CLASS "A" (6 SACK MIN.), OR APPROVED EQUAL.

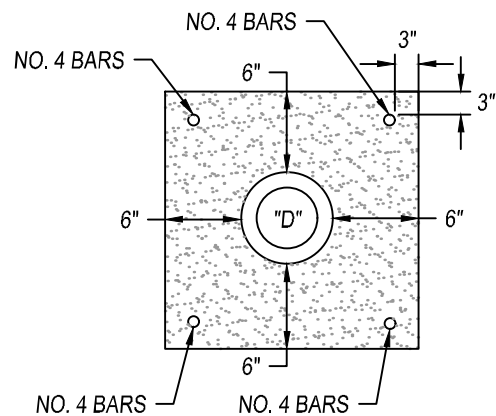

CITY COUNCIL APPROVAL: 01/24/2023

APPROVED BY CITY ENGINEER

APPROVED BY PUBLIC WORKS DIRECTOR

**WATER MAIN AND SANITARY SEWER
MAIN SEPARATION (SHEET 2 OF 2)**

PUBLIC IMPROVEMENT STANDARDS

SS-3

REVISIONS

NAME	BY	DATE

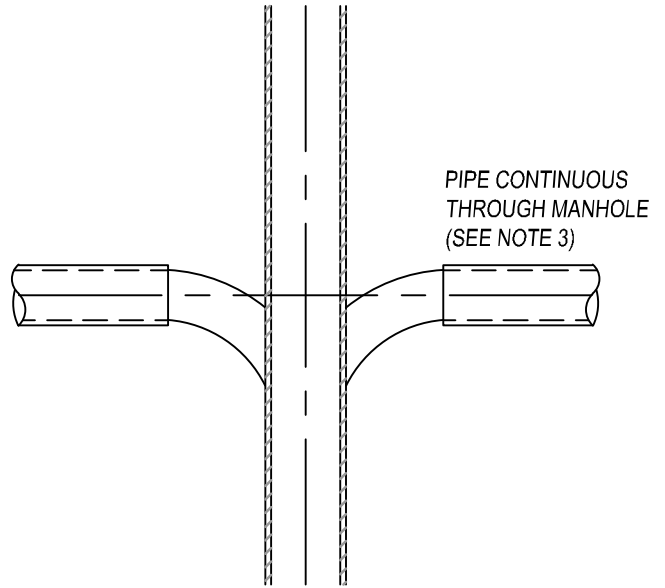
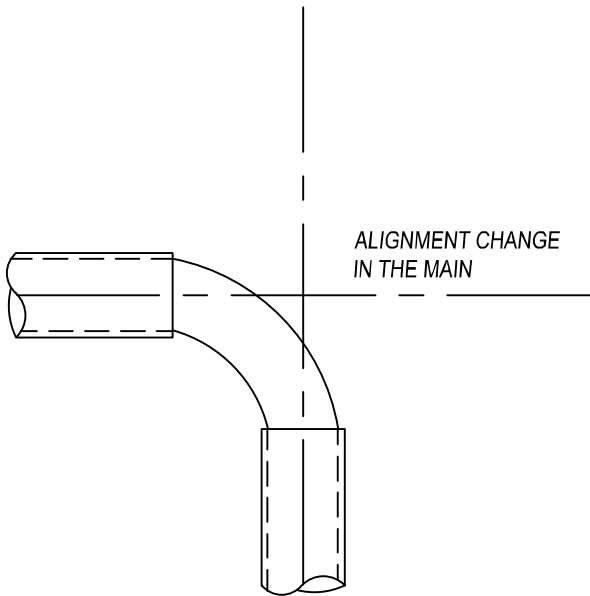
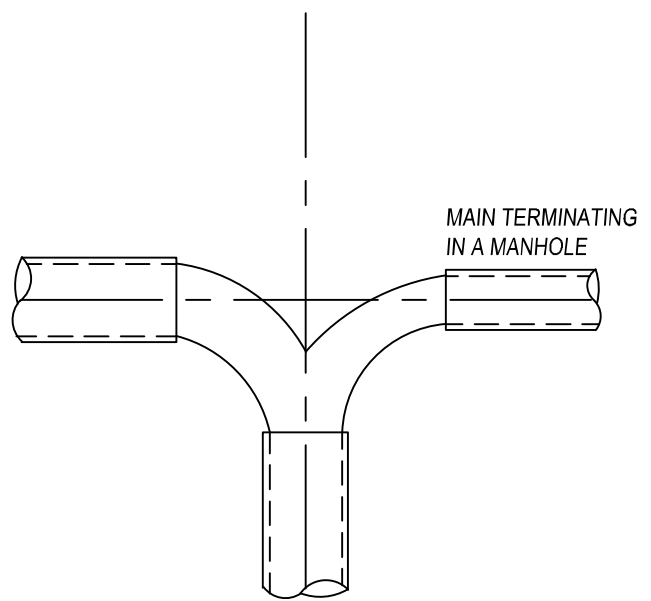
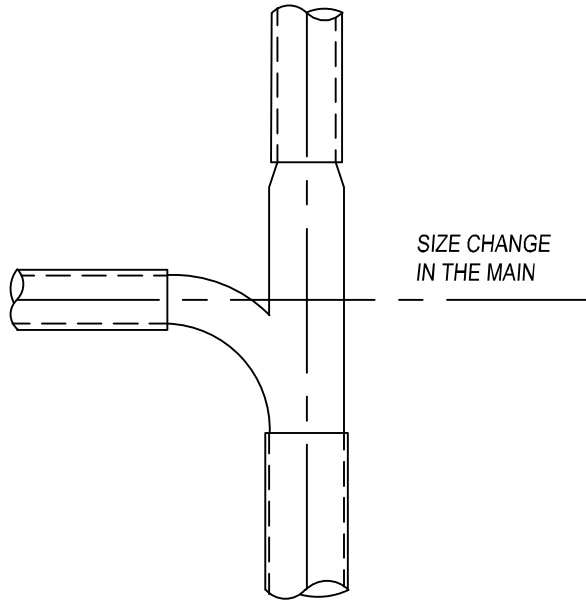

NOTES:

1. PIPE (C-900 OR SDR-35) THROUGH MANHOLE REQUIRES AN APPROVED WATER STOP.
2. TERMINATING PIPES TO EXTEND INTO MANHOLE A MAX. 1".
3. THE TOP HALF OF ALL PIPE WITHIN THE MANHOLE IS TO BE CUT AWAY.
4. PREPARE A SMOOTH TROWELED CONCRETE CHANNEL HAVING UNIFORM GRADIENT BETWEEN PIPE INVERTS.
5. EXTEND THE CHANNEL WALLS UP TO SAME HEIGHT WITH TOP OF THE PIPE.
6. HAND TAMP 9" OF SAND, OR APPROVED BACKFILL MATERIAL, UNDER ALL PIPING COMING IN OR OUT OF THE MANHOLE UP TO THE FIRST JOINT.
7. THE BREADTH OF THE CHANNEL AT EACH JUNCTION MUST ALWAYS BE AS GREAT AS THE CHANNEL RADIUS OF THE CONNECTED PIPE.
8. SLOPE THE BENCHING UP TOWARDS THE MANHOLE WALL AS INDICATED IN THE MANHOLE SECTION. TROWEL THE SURFACE SMOOTH.
9. ON A STANDARD MANHOLE, INCOMING NON-STRAIGHT LINES SHALL HAVE AN INVERT THAT IS AT LEAST 1" HIGHER THAN THE OUT-GOING LINE, UNLESS OTHERWISE APPROVED.
10. MAXIMUM OF 3 INLET PIPES INTO MANHOLE.
11. MAXIMUM OF 2 SANITARY SEWER LATERALS CAN BE CONNECTED TO A MANHOLE.



CITY COUNCIL APPROVAL: 01/24/2023

APPROVED BY CITY ENGINEER
 APPROVED BY PUBLIC WORKS DIRECTOR

**INVERT PLANS OF
STANDARD MANHOLES**

PUBLIC IMPROVEMENT STANDARDS

SS-4

REVISIONS

NAME	BY	DATE

MANHOLE SIZING	
PIPE SIZE	MANHOLE SIZE
0-36"	48"
>36"	72"

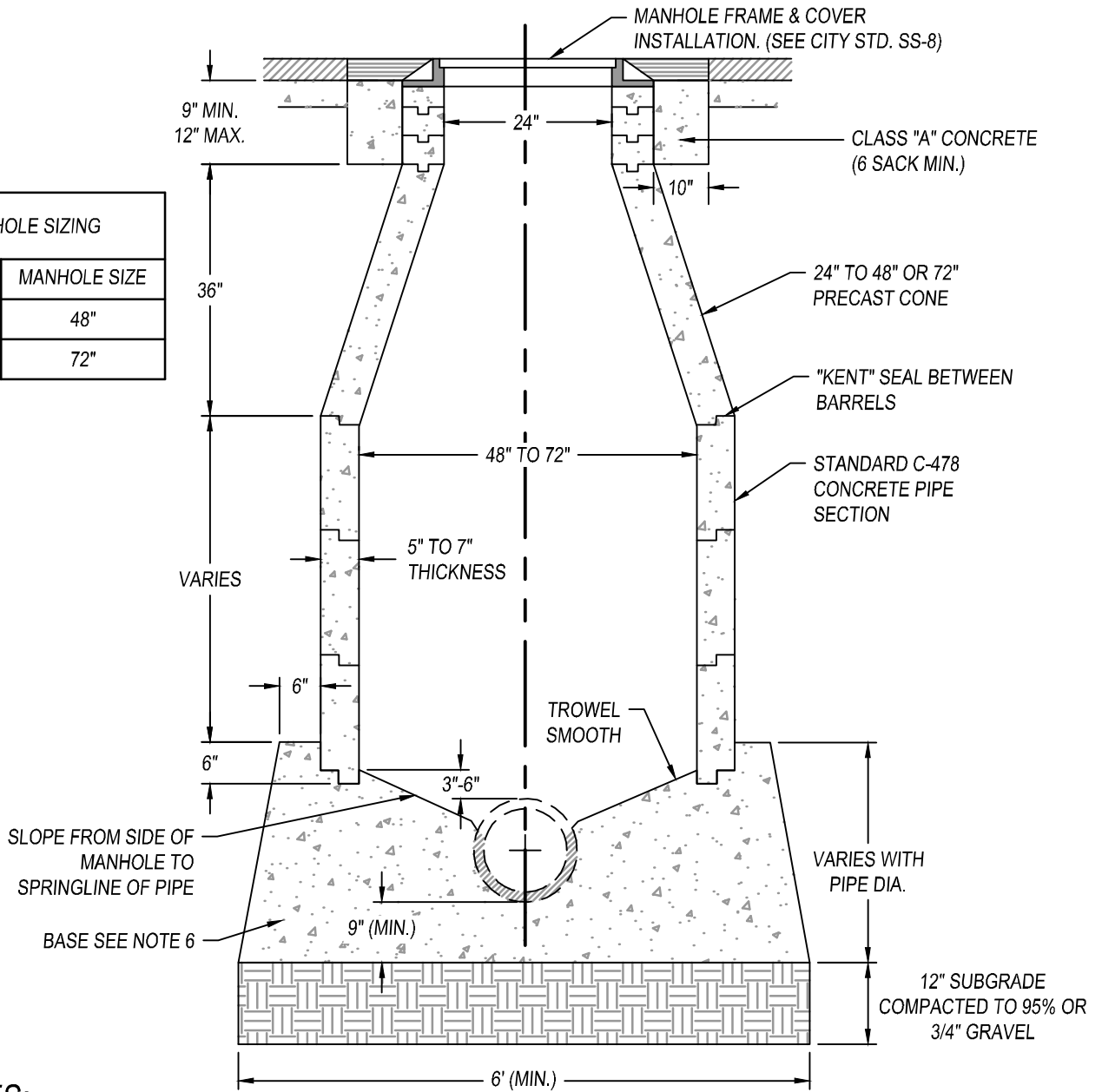

NOTES:

1. ALL CONCRETE SHALL BE CLASS "A" (6 SACK MIN.), TYPE II/IV CEMENT.
2. CONCRETE CONE AND GRADE RINGS SHALL BE PRECAST REINFORCED AS PER ASTM C-478.
3. GROUT AND BAND ALL PIPE JOINTS OR INSTALL "KENT" SEAL NO. 2, OR APPROVED EQUAL.
4. GROUT MIXTURE SHALL BE 1:2 CEMENT TO SAND.
5. WHERE MANHOLES ARE NOT IN STREETS OR TRAVEL WAYS, PLACE TOP 12"-24" ABOVE EXISTING GROUND WITH A 24" CONCRETE COLLAR, UNLESS OTHERWISE SHOWN ON THE PLANS.
6. BASE SHALL BE CLASS "A" (6 SACK MIX WITH 3/4" AGGREGATE).
7. WHEN ADJUSTING A MANHOLE, REFER TO CITY STD. SS-8.
8. SEWER LATERALS SHALL ENTER MANHOLE 1" ABOVE MAIN. HOLE FOR LATERALS SHALL BE BORED OR OTHER APPROVED METHOD BY CITY ENGINEER.
9. NO FLOODING OR JETTING COMPACTION.
10. MAXIMUM DISTANCE BETWEEN MANHOLES SHALL BE 400'.
11. SEWER LATERALS, 6" AND LARGER, REQUIRE A SANITARY SEWER MANHOLE WHEN CONNECTING TO THE SANITARY SEWER MAIN.
12. A MANHOLE IS REQUIRED AT EACH CHANGE IN DIRECTION, EXCLUDING SMALLER THAN 6" SEWER LATERALS.



CITY COUNCIL APPROVAL: 01/24/2023
 APPROVED BY CITY ENGINEER
 APPROVED BY PUBLIC WORKS DIRECTOR

SANITARY SEWER MANHOLE

PUBLIC IMPROVEMENT STANDARDS

SS-5

REVISIONS

NAME	BY	DATE

DROP BOWL MODEL	WILL FIT SIZES UP TO
A4	UP TO 6"
A6	UP TO 8"
B8	UP TO 10"
B10	UP TO 12"
24"	12" AND 15" INLET PIPES
30"	18" INLET

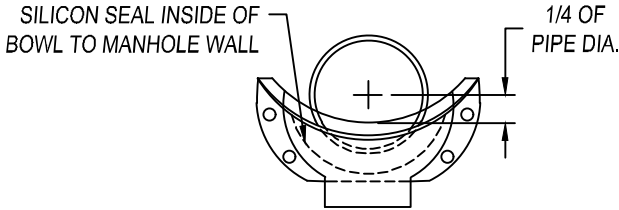

DROP BOWL MOUNTING POSITION

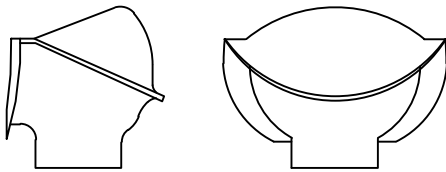

FORCE LINE HOOD

NOTES:

1. ALL INSIDE DROP PIPING TO BE A.B.S. OR PVC SDR-26.
2. CEMENT ALL JOINTS.
3. CLAMPS TO BE 1-1/2 X 12 GA. STAINLESS STEEL, ANCHORED TO M.H. WALL WITH 2-1/2" CADMIUM PLATED BOLTS.

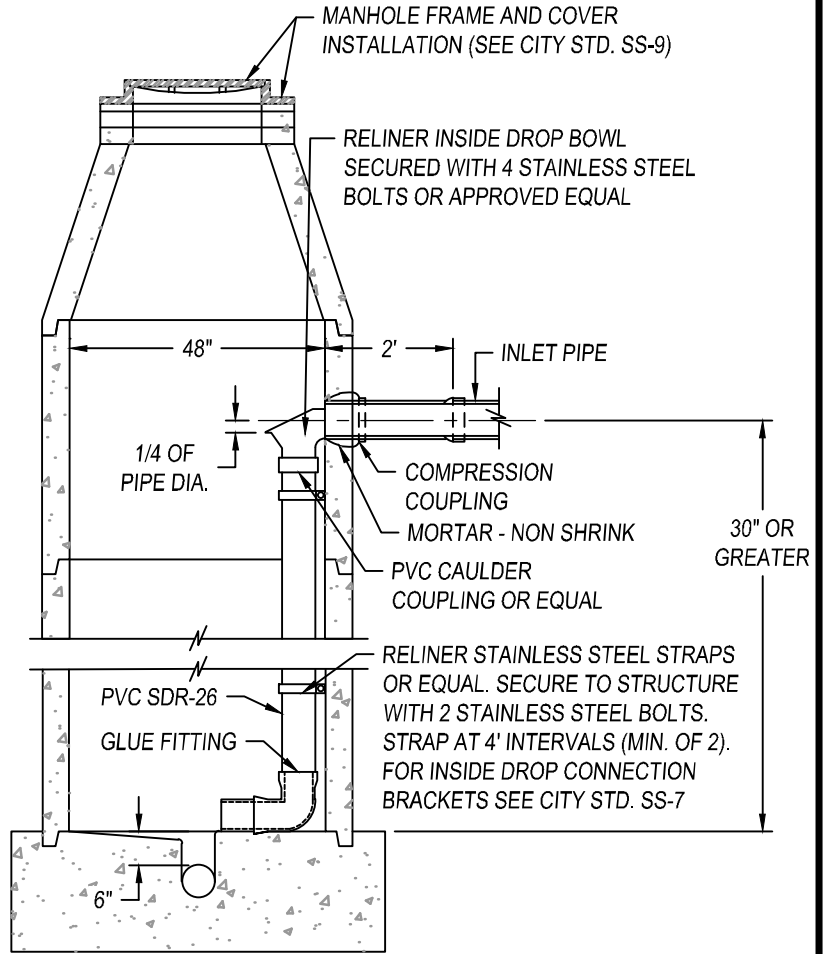

INSIDE DROP CONNECTION

NOTES:

1. ALL INSIDE DROP CONNECTIONS FOR SERVICES AND COLLECTOR SEWERS SHALL USE THE DROP BOWL AS PRODUCED BY: RELINER-DURAN, INC. OR APPROVED EQUAL.
2. DROP BOWL MODEL "A4" SHALL BE USED FOR ALL INLET PIPES UP TO 6" INLETS, "A6" SHALL BE USED UP TO 8" INLETS, "B8" SHALL BE USED UP TO 10" INLETS, "B10" SHALL BE USED UP TO 12" INLETS, 24" DROP BOWL SHALL BE USED FOR 12" AND 15" INLETS, 30" DROP BOWL SHALL BE USED FOR 18" INLETS. LINES LARGER THAN 10" SHALL BE AS APPROVED BY THE CITY ENGINEER PRIOR TO BEGINNING WORK.
3. THE FORCE LINE HOOD SHALL BE ATTACHED ON MODELS "A4" AND "A6" WHEN THE INCOMING LINE IS FROM A FORCE MAIN OR THE SLOPE IS S=0.03 OR GREATER.
4. SECURE DROP PIPE TO MANHOLE WALL WITH RELINER-DURAN, INC. STAINLESS STEEL ADJUSTABLE CLAMPING BRACKETS OR EQUAL. SEE CITY STD. SS-7.
5. ATTACH THE DROP BOWL AND EACH CLAMPING BRACKET TO THE MANHOLE WALL WITH 3/8" X 3-3/4" RAMSET/RED HEAD BOLTS HELD IN PLACE WITH 2 STAGE EPOXY PASTE. EPOXY SHALL MEET THE FOLLOWING REQUIREMENTS:
6. EPOXY PASTE SHALL BE A TWO COMPONENT, 100% SOLID SYSTEM. EPOXY SHALL BE SIKADUR 31 HI-MOD GEL BY SIKA CORPORATION OR APPROVED EQUAL.
7. THE EPOXY PASTE SHALL DEVELOP A MIN. COMPRESSIVE STRENGTH OF 5,000 PSI IN 28 DAYS WHEN TESTED IN ACCORDANCE WITH ASTM D695 AT 73 DEGREES.
8. THE EPOXY PASTE SHALL DEVELOP A MIN. TENSILE STRENGTH OF 3,000 PSI IN 14 DAYS WHEN TESTED IN ACCORDANCE WITH ASTM D638.
9. THE EPOXY PASTE SHALL DEVELOP A MIN. BOND STRENGTH OF 2,000 PSI IN 2 DAYS WHEN TESTED IN ACCORDANCE WITH ASTM C882 (HARDENED CONCRETE TO HARDENED CONCRETE).
10. MANUFACTURER'S INSTRUCTIONS SHALL BE PRINTED ON EACH CONTAINER IN WHICH THE MATERIALS ARE PACKAGED.

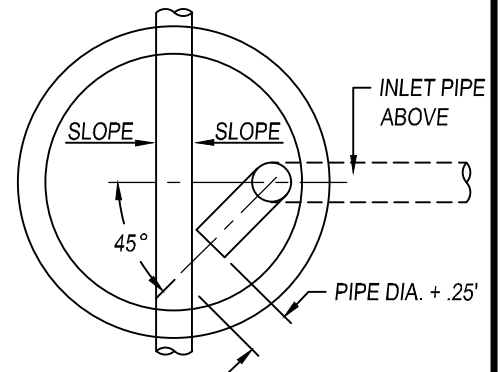

INSIDE DROP - PLAN



CITY COUNCIL APPROVAL: 01/24/2023
 APPROVED BY CITY ENGINEER
 APPROVED BY PUBLIC WORKS DIRECTOR

SANITARY SEWER DROP MANHOLE

PUBLIC IMPROVEMENT STANDARDS

SS-6

REVISIONS

NAME	BY	DATE

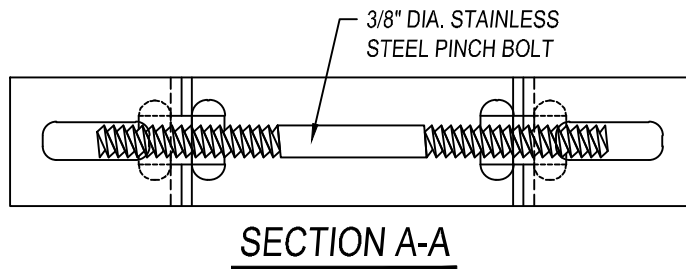
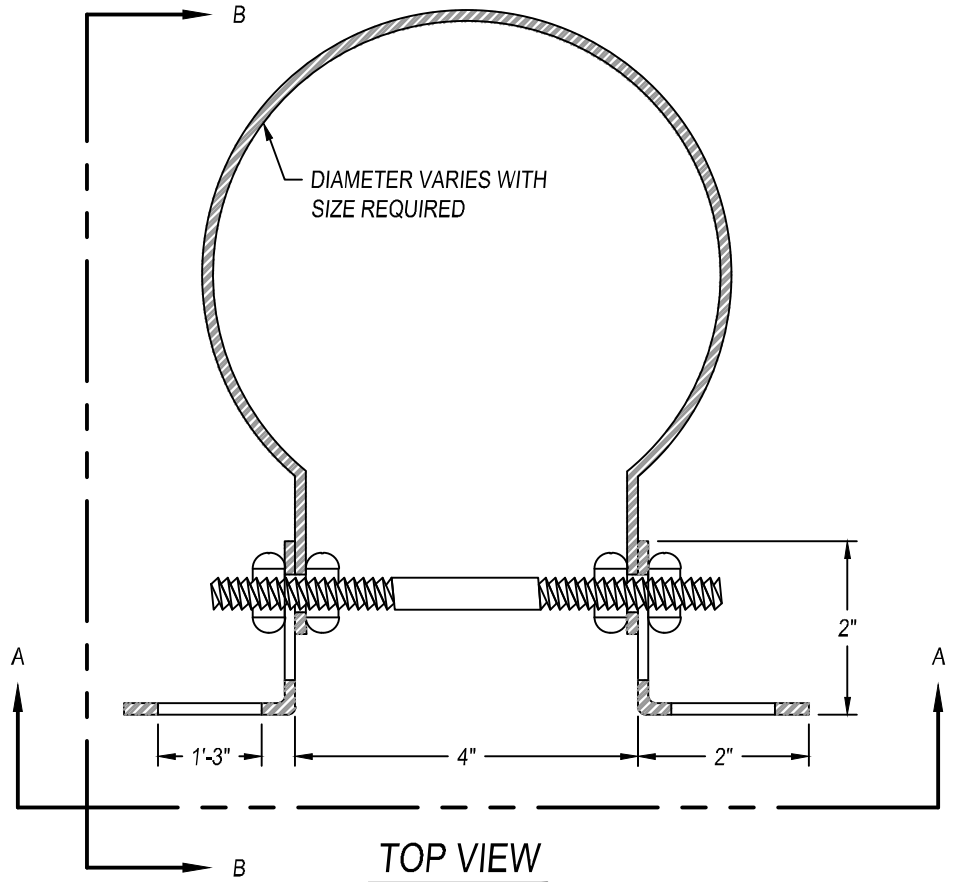
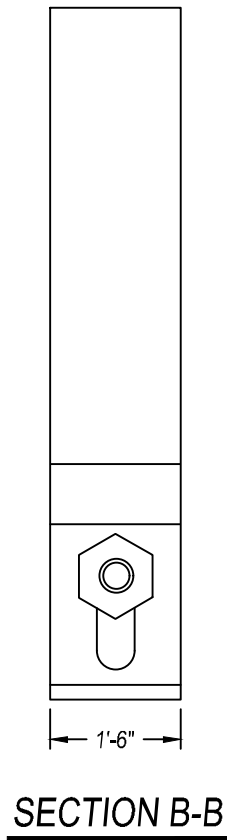

NOTES:

1. STAINLESS STEEL ADJUSTABLE CLAMPING BRACKET AS MANUFACTURED BY RELINER-DURAN, INC. OR APPROVED EQUAL.
2. CLAMP AND BRACKETS SHALL BE TYPE 304 STAINLESS STEEL, 11 GAUGE (.1196").
3. 3/16"Ø PINCH BOLT AND NUTS SHALL BE TYPE 18-8 STAINLESS STEEL.
4. STANDARD SIZES TO FIT 4", 6", 8", & 10" PVC SEWER PIPE SDR-26.
5. FOR PIPE SIZES LARGER THAN 10", CITY ENGINEER SHALL APPROVE DESIGN PRIOR TO BEGINNING WORK.



CITY COUNCIL APPROVAL: 01/24/2023

[Signature]
APPROVED BY CITY ENGINEER

[Signature]
APPROVED BY PUBLIC WORKS DIRECTOR

**SANITARY SEWER DROP MANHOLE -
CLAMPING BRACKET**

PUBLIC IMPROVEMENT STANDARDS

SS-7		
REVISIONS		
NAME	BY	DATE

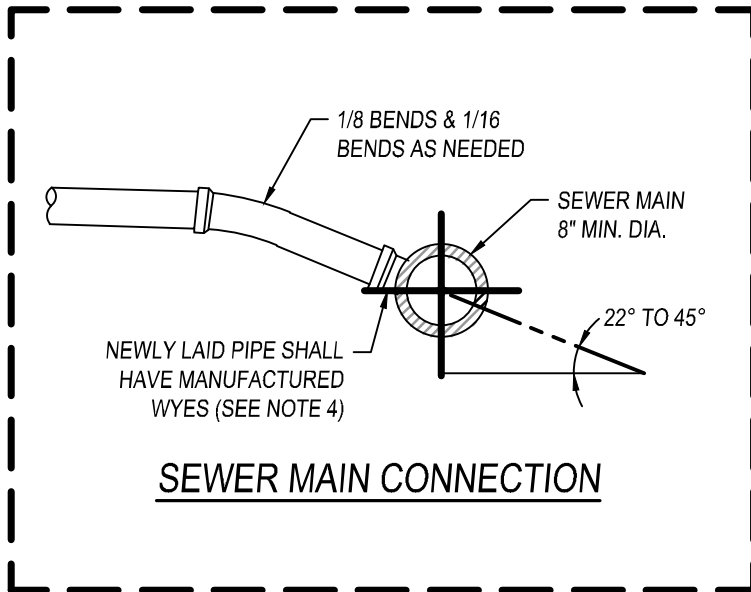
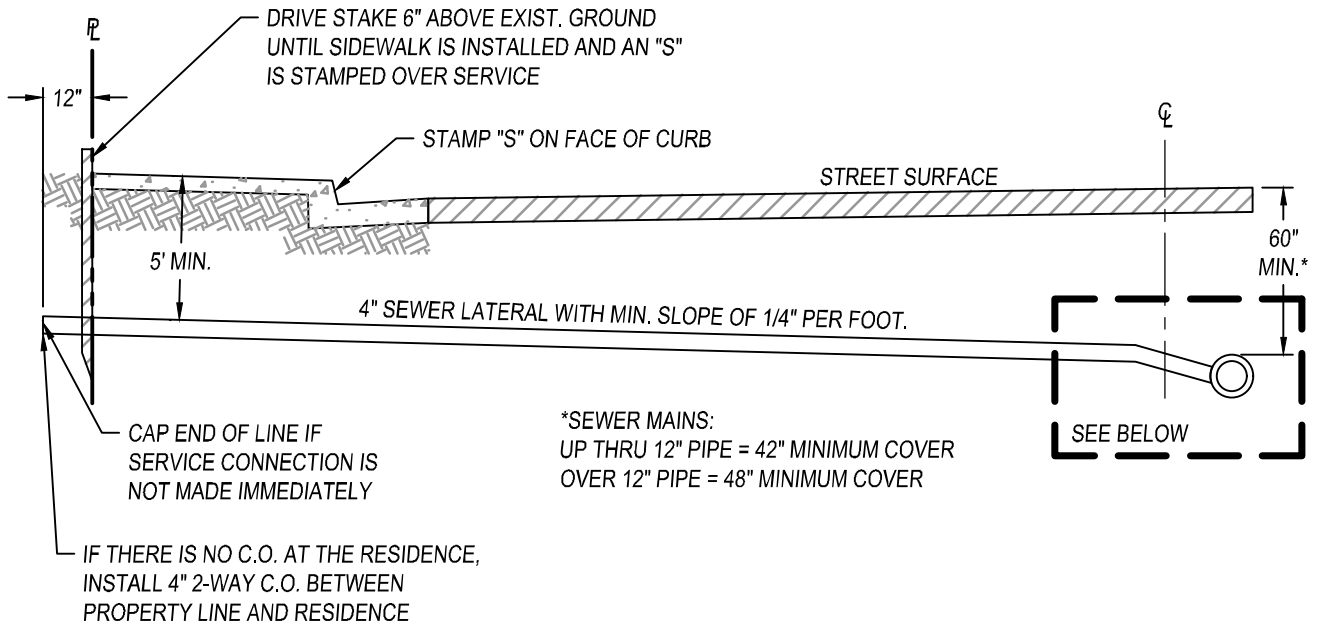

NOTES:

1. FOR DEPTHS OF LESS THAN 3' OF COVER, USE DUCTILE IRON PIPE OR C-900 PVC PIPE WITH APPROVAL OF THE CITY OF DINUBA.
2. THE SLOPE OF SEWER LATERALS SHALL BE A MINIMUM OF 2% OR AS APPROVED BY THE CITY ENGINEER.
3. SEWER LATERALS SHALL BE SHOWN ON THE AS-BUILT PLANS.
4. FOR CONNECTIONS TO EXISTING MAINS, USE PLASTIC SADDLE W/STAINLESS STEEL 2" CLAMPS, CONTRACTOR TO VERIFY CONNECTION IS WATER TIGHT.
5. LOCATION OF SEWER LATERAL SHALL BE 5' FROM CENTER LOT LINE.
6. REPLACEMENT OF AN EXISTING SEWER LATERAL WILL REQUIRED A 2-WAY SANITARY SEWER CLEANOUT LOCATED 24" FROM THE EXTERIOR WALL. CLEANOUT CAP SHALL BE A MINIMUM OF 2" ABOVE GRADE.
7. 5 FOOT MINIMUM BETWEEN THE TOP OF PIPE AND FINISH GRADE, UNLESS OTHERWISE SPECIFIED BY THE CITY ENGINEER.



CITY COUNCIL APPROVAL: 01/24/2023

APPROVED BY CITY ENGINEER

APPROVED BY PUBLIC WORKS DIRECTOR

SEWER LATERALS

PUBLIC IMPROVEMENT STANDARDS

SS-8

REVISIONS

NAME	BY	DATE

TOP VIEW

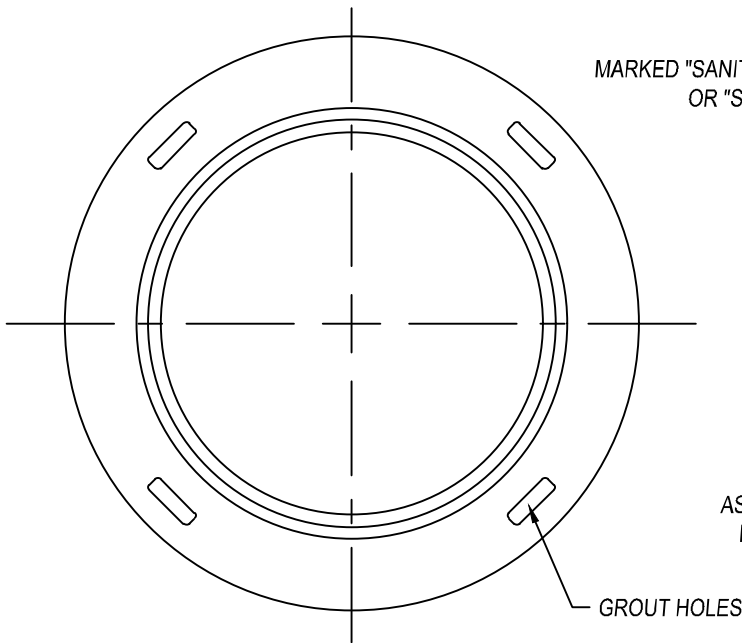

TOP VIEW

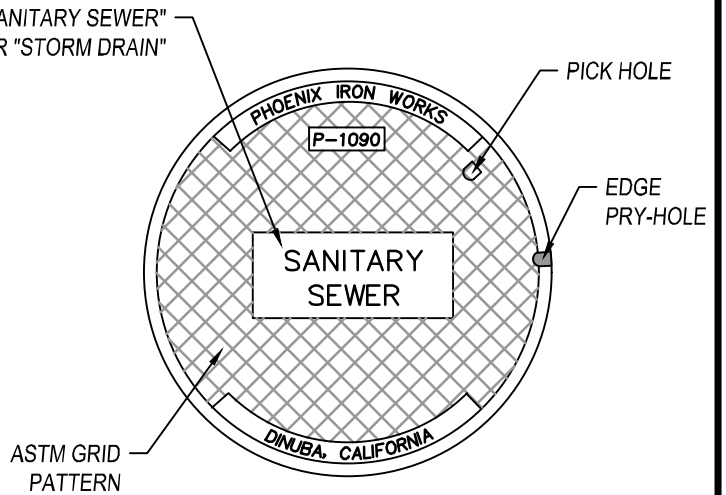

MANUFACTURER:

"PHOENIX IRON WORKS"
 24" FULL TRAFFIC TYPE NON-ROCKING MANHOLE
 FRAME AND COVER MODEL NO. P-1090, OR
 APPROVED EQUAL.

COVER SIDE VIEW

REPLACE & COMPACT 2" MIN. A.C.
 AND LEVEL WITH EXIST. SURFACE.
 FINISH A.C. GRADE 1/8" ABOVE
 COVER IF SURFACE IS CONCRETE

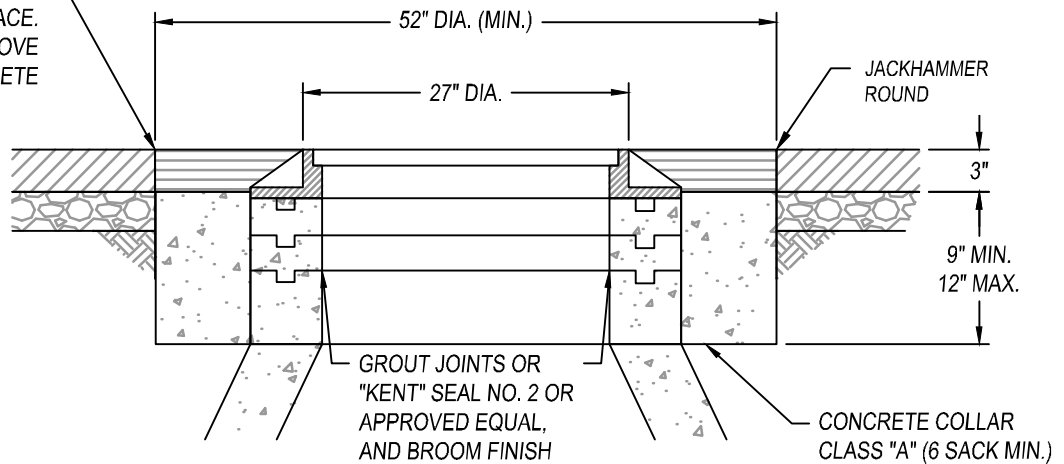

MANHOLE ADJUSTMENT



CITY COUNCIL APPROVAL: 01/24/2023

[Signature]
 APPROVED BY CITY ENGINEER

[Signature]
 APPROVED BY PUBLIC WORKS DIRECTOR

MANHOLE FRAME AND COVER

PUBLIC IMPROVEMENT STANDARDS

SS-9

REVISIONS

NAME	BY	DATE

SECTION A-A FRAME & COVER

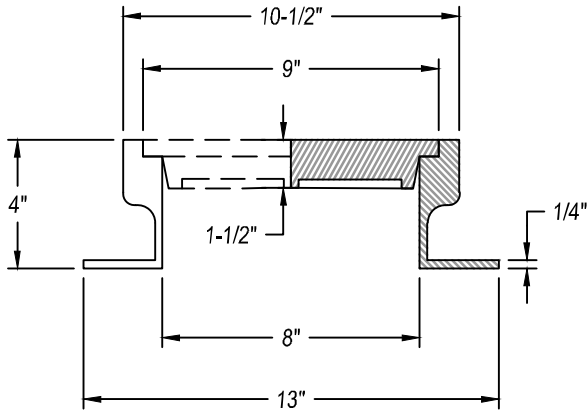

PLAN VIEW

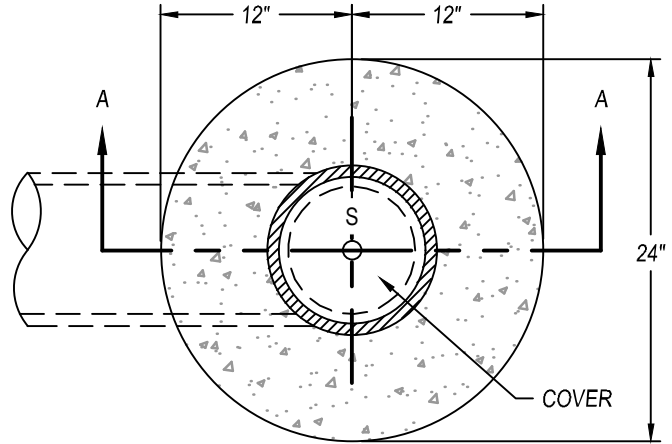

MANUFACTURER

"PHOENIX IRON WORKS" FRAME AND COVER MODEL NO. P-2502, OR APPROVED EQUAL.

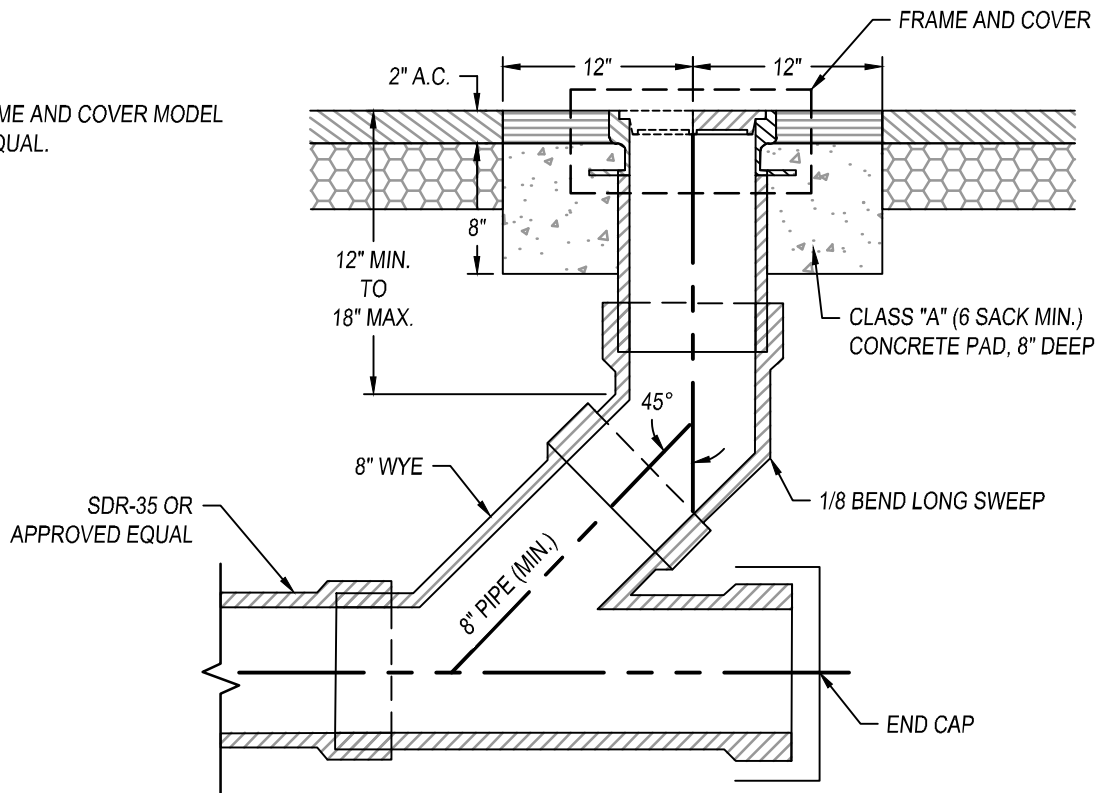

NOTES:

1. PIPE AND FITTINGS, EXCEPT AS OTHERWISE SHOWN HEREIN, SHALL BE OF THE SAME MATERIAL AS THE SEWER, UNLESS APPROVED ADAPTORS ARE UTILIZED.
2. PIPES AND FITTINGS SHALL BE PROPERLY ALIGNED AND MAINTAINED WHILE CONCRETE IS BEING PLACED AND ALLOWED TO HARDEN, JOINTS FOR PIPES AND FITTINGS SHALL BE MADE PRIOR TO PLACING CONCRETE. CONCRETE FOR BEDDING, ENCASEMENT, AND WALL SUPPORT FOR PIPES AND FITTINGS SHALL BE PLACED UNIFORMLY AROUND THE PIPE AND FITTINGS, AND SHALL BE CLASS "A".
3. THE ACCESS FRAME, COVER AND CAP SHALL BE CAST IRON.
4. CLEANOUT INSTALLED BEHIND AN END STREET BARRICADE SHALL HAVE A 2'X2'X8" CONCRETE PAD PLACED AROUND IT.
5. JACK-HAMMER PAVEMENT AROUND THE EDGE PRIOR TO REPAVING
6. REPLACE AND COMPACT 2" AND 3" OF A.C. AND LEVEL WITH EXISTING STREET SURFACE. FINISH NEW A.C. GRADE 1/8" ABOVE COVER



CITY COUNCIL APPROVAL: 01/24/2023
 APPROVED BY CITY ENGINEER
 APPROVED BY PUBLIC WORKS DIRECTOR

SEWER CLEANOUT

PUBLIC IMPROVEMENT STANDARDS

SS-10

REVISIONS

NAME	BY	DATE

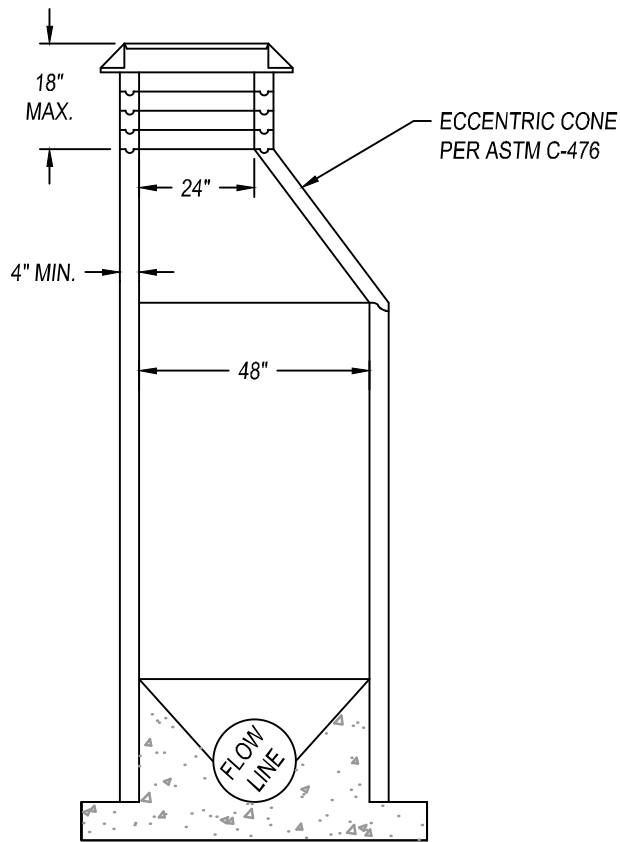

ECCENTRIC MANHOLE

NOTES:

1. CONSTRUCTION OF MANHOLE SHALL BE IN ACCORDANCE WITH THE SEWER MANHOLE STANDARD SS-5, EXCEPT AS MODIFIED HEREON.



CITY COUNCIL APPROVAL: 01/24/2023
 APPROVED BY CITY ENGINEER
 APPROVED BY PUBLIC WORKS DIRECTOR

ECCENTRIC MANHOLE

PUBLIC IMPROVEMENT STANDARDS

SS-11

REVISIONS		
NAME	BY	DATE

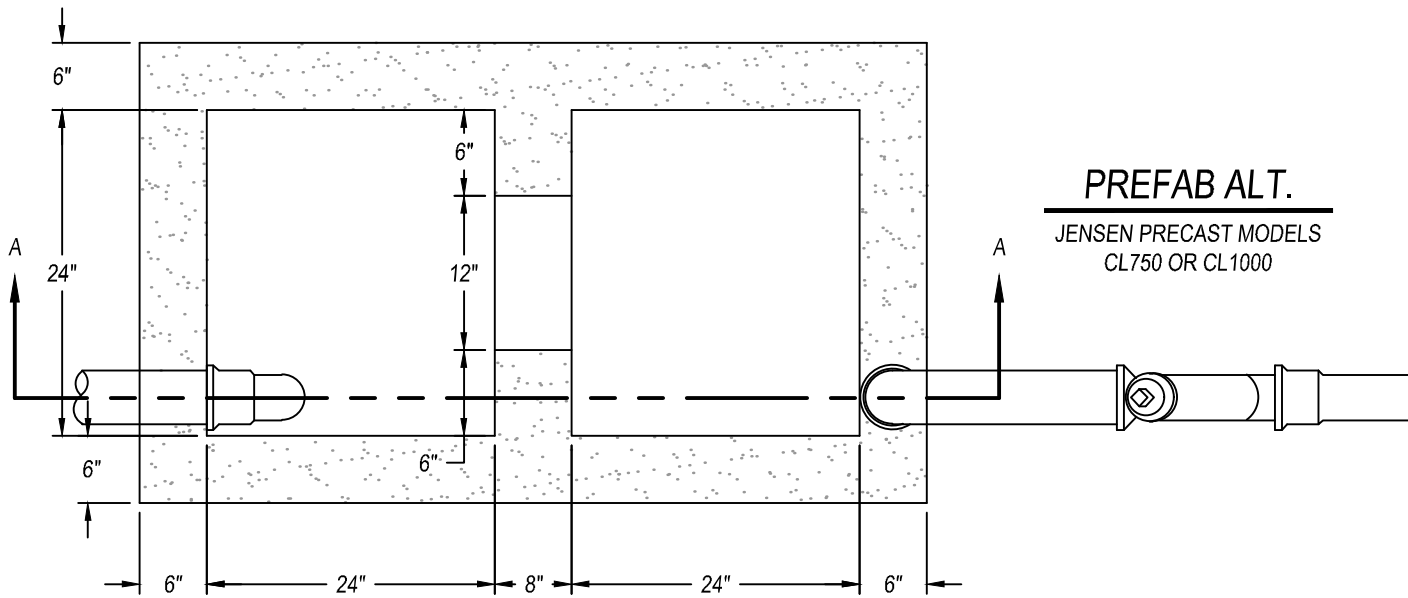

SECTIONAL PLAN

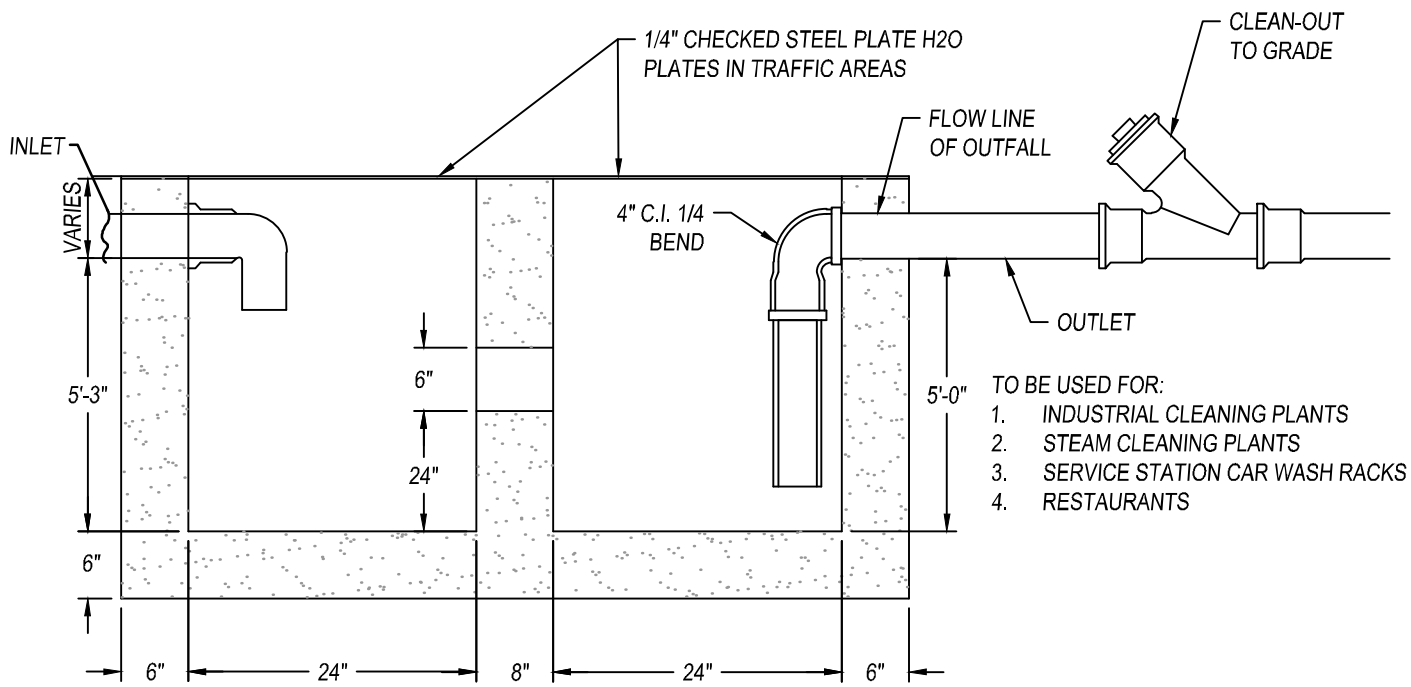

SECTION A-A

NOTES:

- 1. SIZING IS A MINIMUM AND A LICENSED ENGINEER SHALL PROVIDE A DESIGN



CITY COUNCIL APPROVAL: 01/24/2023

APPROVED BY CITY ENGINEER
 APPROVED BY PUBLIC WORKS DIRECTOR

**COMMERCIAL AND INDUSTRIAL
 GREASE TRAP**

PUBLIC IMPROVEMENT STANDARDS

SS-12

REVISIONS		
NAME	BY	DATE

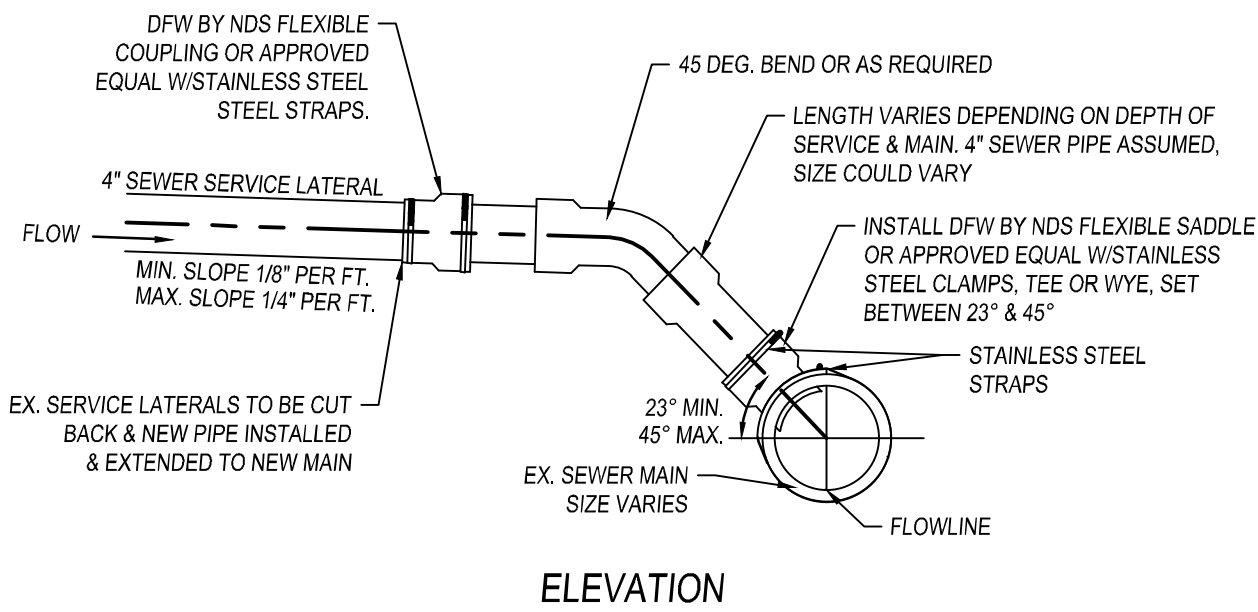
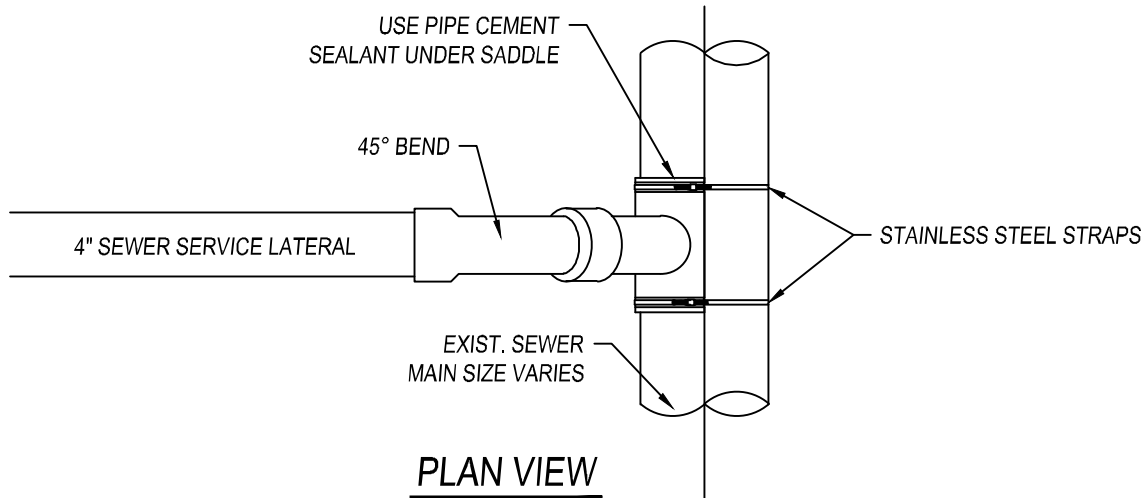

NOTES:

1. FOR PIPES 6" TO 12" IN DIAMETER, A LICENSED CONTRACTOR (C36) WHO HAS THE PROPER EQUIPMENT AND PERMITS IS CONSIDERED AN APPROVED AGENT AND MAY CORE INTO THE CITY'S SEWER MAINS OR REMOVE A SECTION AND INSTALL A WYE OR TEE.
2. FOR SEWER MAINS 18" OR LARGER, A MANHOLE MUST BE CONSTRUCTED WHERE CORINGS ARE MADE.
3. THE CITY PUBLIC WORKS INSPECTOR MUST OBSERVE ALL SADDLE & CORE CONNECTIONS TO EXISTING CITY SEWER MAINS.
4. VITRIFIED CLAY PIPE SADDLES SHALL BE EXTRA STRENGTH CLAY PIPE AND SHALL CONFORM TO THE REQUIREMENTS OF THE "WEST COAST STANDARDS OF THE CLAY PIPE INSTITUTE".
5. OPENINGS INTO EXISTING SEWER MAINS SHALL BE MADE ONLY LARGE ENOUGH TO ADMIT ALL OF SADDLE FITTINGS.
6. THIS STANDARD DETAIL IS ONLY TO BE USED WHEN CONNECTING TO EXISTING SEWER MAIN LINES. NEW LINES SHALL HAVE WYES AS PER CITY STD. SS-8.
7. APPLY SILICON SEALANT TO COMPRESSION SCREWS AND WRAP STAINLESS STEEL STRAP WITH THREE (3) LAYERS OF PVC TAPE.



CITY COUNCIL APPROVAL: 01/24/2023
 APPROVED BY CITY ENGINEER
 APPROVED BY PUBLIC WORKS DIRECTOR

**SEWER LATERAL SERVICE CONNECTION
 INTO EXISTING SEWER MAIN
 PUBLIC IMPROVEMENT STANDARDS**

SS-13

REVISIONS		
NAME	BY	DATE

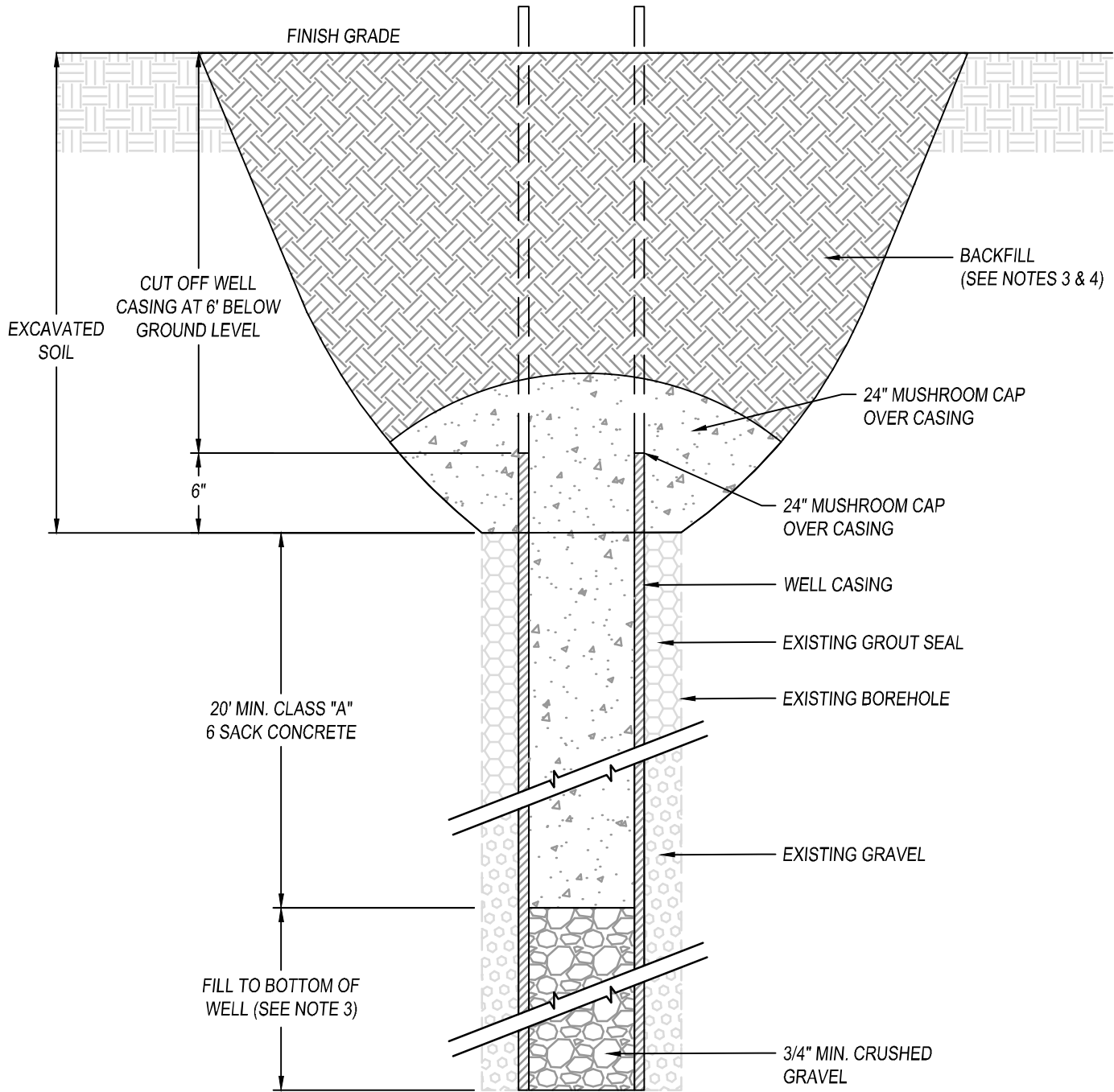

NOTES:

1. IMPERVIOUS MATERIALS INCLUDE NEAT CEMENT, SAND-CEMENT GROUT, CONCRETE AND HIGH-SOLIDS BENTONITE.
2. FILL INCLUDES CLASS "A" CONCRETE (6 SACK MIN.) OR SLURRY ONLY.
3. ORGANIC MATERIALS SHALL NOT BE USED.
4. A PERMIT SHALL BE OBTAINED FROM CITY AND/OR COUNTY, AND A WELL LOG SHALL BE PROVIDED.
5. A CITY INSPECTOR SHALL BE ON SITE DURING WELL ABANDONMENT.
6. ALL WORK MUST COMPLY WITH TULARE COUNTY ENVIRONMENTAL HEALTH REQUIREMENTS.
7. DURING PERIODS WHEN NO WORK IS BEING DONE ON THE WELL, SUCH AS OVERNIGHT OR WHILE WAITING FOR SEALING MATERIAL TO SET, THE WELL AND ANY SURROUNDING EXCAVATION SHALL BE COVERED. THE COVER SHALL BE SUFFICIENTLY ANCHORED AND STRONG ENOUGH TO KEEP FOREIGN MATERIAL FROM ENTERING WELL.



CITY COUNCIL APPROVAL: 01/24/2023

[Signature]
APPROVED BY CITY ENGINEER

[Signature]
APPROVED BY PUBLIC WORKS DIRECTOR

EXISTING WELL ABANDONMENT

PUBLIC IMPROVEMENT STANDARDS

W-1

REVISIONS

NAME	BY	DATE

MANUFACTURER:
 "PHOENIX IRON WORKS" FRAME
 AND COVER MODEL NO. P-7001, OR
 APPROVED EQUAL

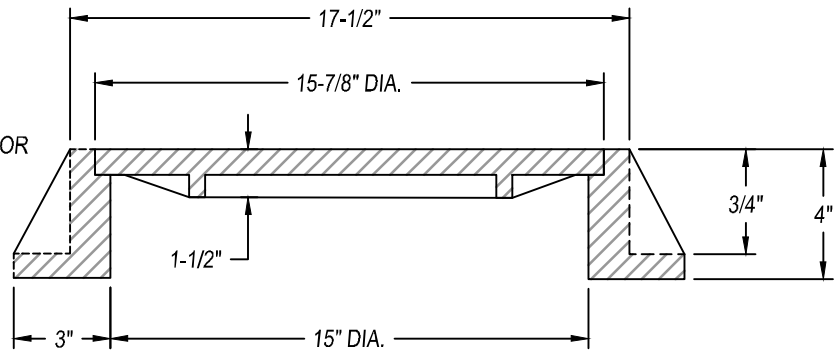

COVER-SIDE VIEW

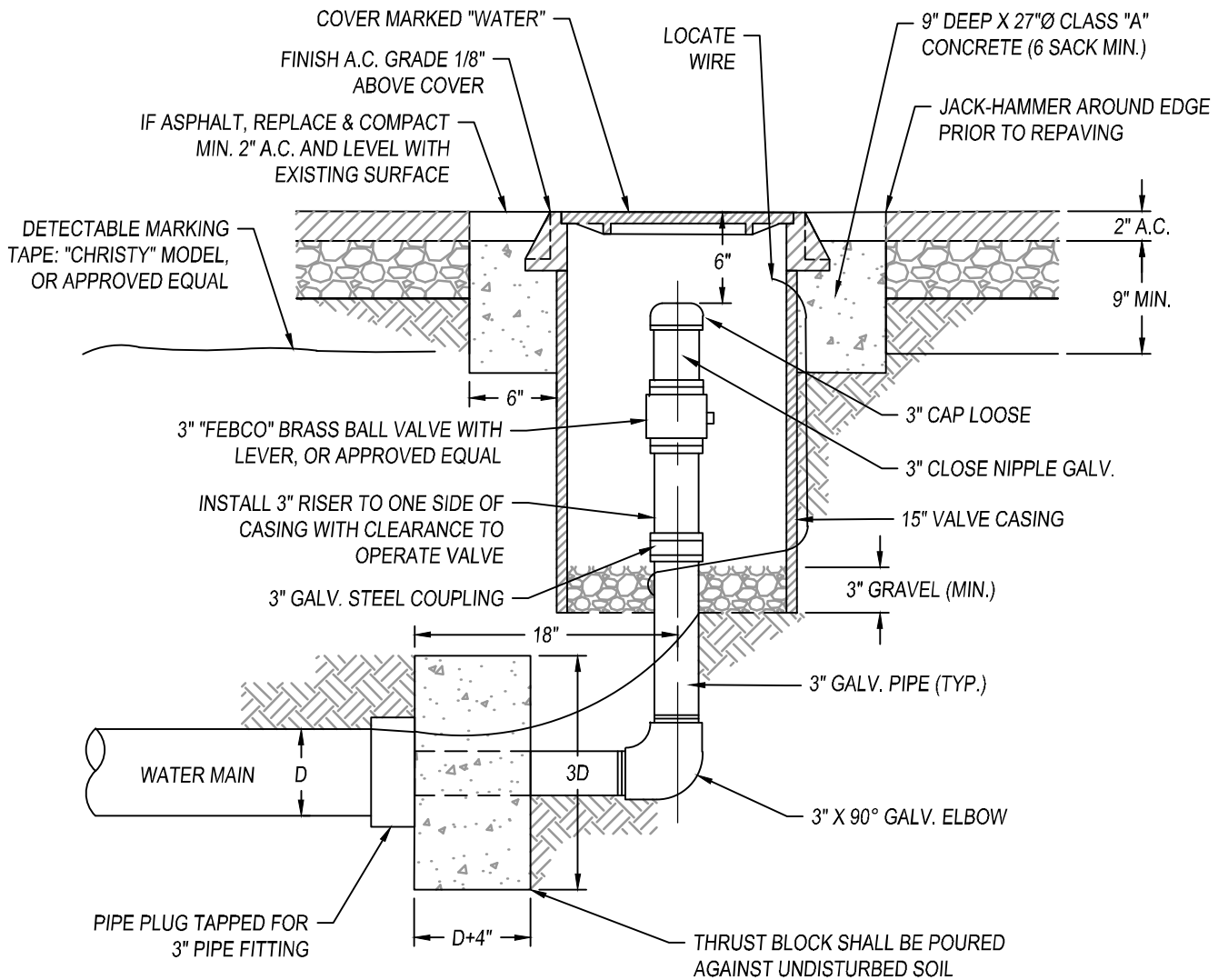

BLOW-OFF FRAME & COVER



CITY COUNCIL APPROVAL: 01/24/2023
 APPROVED BY CITY ENGINEER
 APPROVED BY PUBLIC WORKS DIRECTOR

WATER BLOW-OFF
PUBLIC IMPROVEMENT STANDARDS

W-2		
REVISIONS		
NAME	BY	DATE

A						
PIPE SIZE	90° BEND	45° BEND	11 1/4° OR 22 1/2° BEND	TEE OR END DEAD	TEE W/PLUG	CROSS
8"	39"	33"	30"	33"	33"	27"
10"	45"	36"	33"	36"	36"	39"
12"	54"	42"	36"	44"	44"	46"
18"	94"	60"	42"	76"	76"	88"

B						
PIPE SIZE	90° BEND	45° BEND	11 1/4° OR 22 1/2° BEND	TEE OR END DEAD	TEE W/PLUG	CROSS
8"	24"	24"	18"	21"	24"	30"
10"	24"	24"	21"	21"	24"	30"
12"	24"	24"	21"	21"	24"	30"
18"	39"	39"	39"	39"	39"	42"

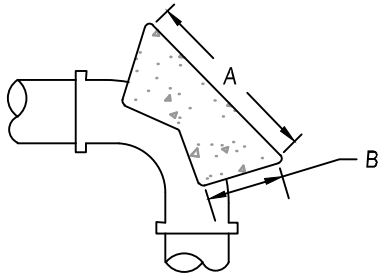

90° BEND

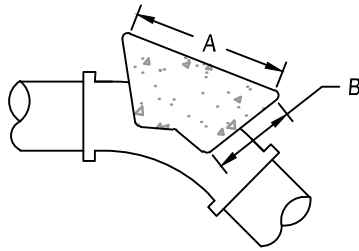

45° BEND

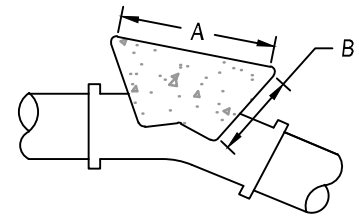

22.5° BEND

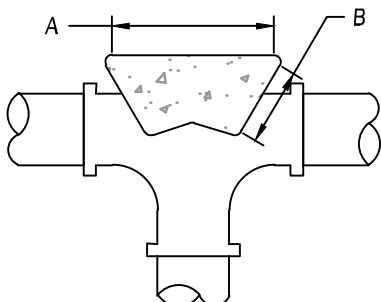

TEE

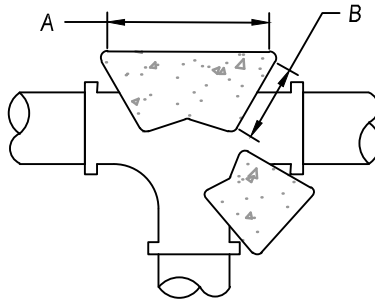

TEE W/ PLUG

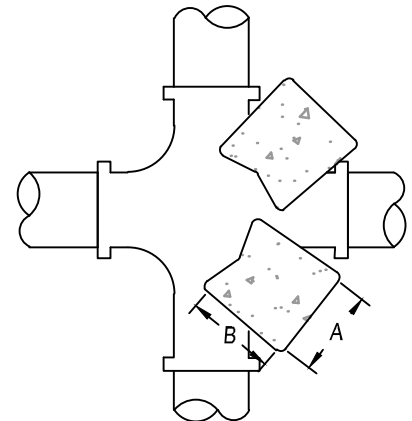

CROSS

NOTES:

1. THRUST BLOCKS SHALL BE USED FOR PIPES WITH 4" DIAMETER OR LARGER.
2. THRUST BLOCKS TO BE CONSTRUCTED OF CLASS "A" CONCRETE (6 SACK MIN.)
3. MINIMUM THICKNESS OF THRUST BLOCKS SHALL BE 6 INCHES.
4. THRUST BLOCKS TO BE POURED AGAINST UNDISTURBED SOIL.
5. AREAS GIVEN ARE FOR CLASS 150 PIPE AT PRESSURE OF 150 P.S.I IN SOIL WITH 2,000 P.S.F. CAPACITY. INSTALLATION USING DIFFERENT PIPE, TEST PRESSURE, AND/OR SOIL TYPES SHOULD ADJUST AREAS ACCORDINGLY, SUBJECT TO APPROVAL OF CITY ENGINEER.
6. THRUST BLOCKS SHALL BE POURED A MIN. OF 5 DAYS BEFORE PRESSURIZING THE SYSTEM.
7. MEG-A-LUG JOINTS ARE REQUIRED AND THRUST BLOCKS CANNOT BE USED IN LIEU OF MEG-A-LUG JOINTS.



CITY COUNCIL APPROVAL: 01/24/2023

APPROVED BY CITY ENGINEER
 APPROVED BY PUBLIC WORKS DIRECTOR

THRUST BLOCK

PUBLIC IMPROVEMENT STANDARDS

W-3

REVISIONS

NAME	BY	DATE

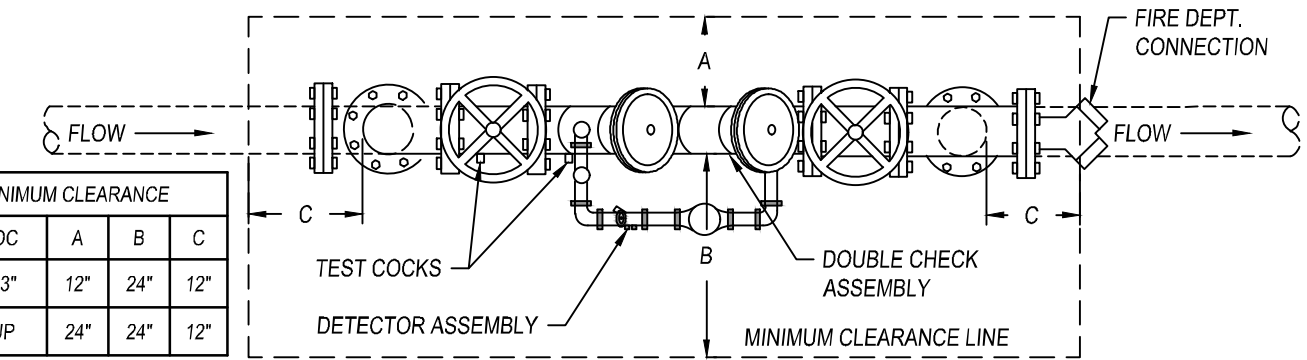
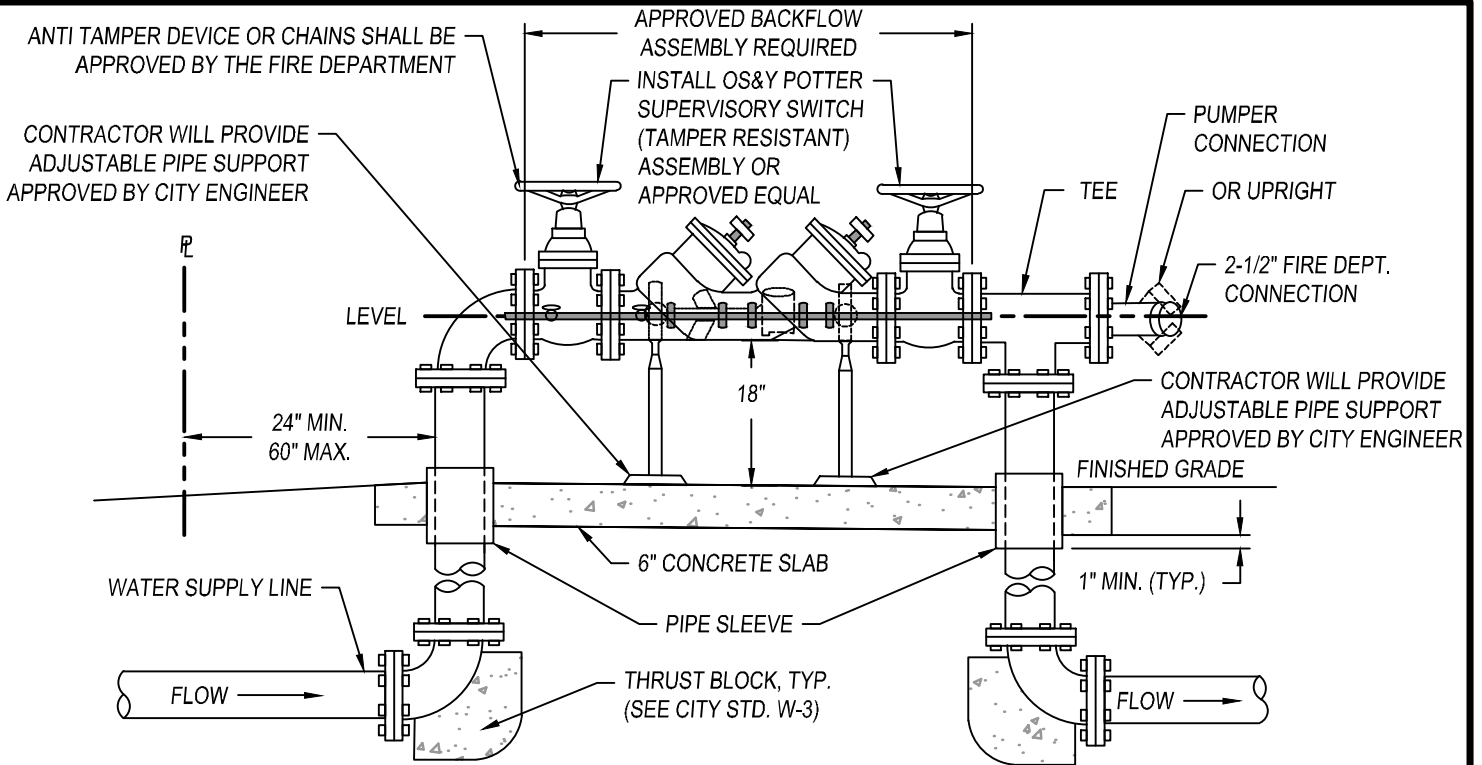

MINIMUM CLEARANCE			
SIZE DC	A	B	C
1" TO 3"	12"	24"	12"
4" & UP	24"	24"	12"

NOTES:

1. RESILIENT SEATED SHUT OFF VALVES AND TEST COCKS ARE REQUIRED.
2. NO TAPS, TEES OR CONNECTIONS OF ANY KIND ARE PERMITTED BETWEEN THE WATER METER AND THE BACKFLOW ASSEMBLY.
3. PROTECTION FROM FREEZE DAMAGE IS REQUIRED IN EXPOSED AREAS.
4. ASSEMBLY MUST BE ACCESSIBLE FOR TESTING AND MAINTENANCE BY THE CITY OF DINUBA PUBLIC WORKS DEPARTMENT.
5. ASSEMBLY TO BE THE SAME SIZE AS THE WATER SUPPLY LINE PER UNIFORM PLUMBING CODE.
6. PRESSURE LOSS THROUGH ASSEMBLY MUST BE INCLUDED IN PRESSURE LOSS CALCULATIONS FOR SIZING OF THE WATER SYSTEM PER UNIFORM FIRE CODE.
7. MINIMUM CLEARANCE AROUND ASSEMBLY MUST BE MAINTAINED. REFER TO MINIMUM CLEARANCE CHART ON THIS PAGE.
8. ANY DEVIATION FROM THESE REQUIREMENTS SHALL BE APPROVED BY THE WATER SYSTEM MANAGER OR CROSS CONNECTION CONTROL SPECIALIST PRIOR TO INSTALLATION.
9. THE BACKFLOW PREVENTER DEVICES AND INSTALLATIONS SHALL BE APPROVED BY THE CITY OF DINUBA PUBLIC WORKS DEPARTMENT.
10. BACKFLOW ASSEMBLY SHALL BE INSPECTED AND TESTED BY THE PUBLIC WORKS DEPARTMENT OR PROVIDE A CERTIFICATE SHOWING THE ASSEMBLY WAS TESTED AND PASSED.
11. IF VALVES ARE RESILIENT SEAT, TYPE 'A' POST INDICATOR IS REQUIRED.
12. A CITY STANDARD FIRE HYDRANT MUST BE WITHIN 25' OF FIRE DEPARTMENT CONNECTION OR INSTALLED WITHIN 25' OF THE FIRE HYDRANT CONNECTION.
13. LOCATION OF THE ASSEMBLY MUST BE APPROVED BY THE FIRE DEPARTMENT.
14. OSY AND FBC WILL LABELED WITH BUILDING ADDRESS AND SUITE ADDRESS.
15. ALL FIRE DEPARTMENT INFRASTRUCTURE SHALL BE INSTALLED PER THE DIRECTION OF THE DINUBA FIRE DEPARTMENT.
16. CONCRETE BOLLARDS MAY REQUIRED AT THE DISCRETION OF THE DINUBA FIRE DEPARTMENT.



CITY COUNCIL APPROVAL: 01/24/2023

APPROVED BY CITY ENGINEER

APPROVED BY PUBLIC WORKS DIRECTOR

BACKFLOW DEVICE AND FIRE DEPARTMENT CONNECTION

PUBLIC IMPROVEMENT STANDARDS

W-4		
REVISIONS		
NAME	BY	DATE

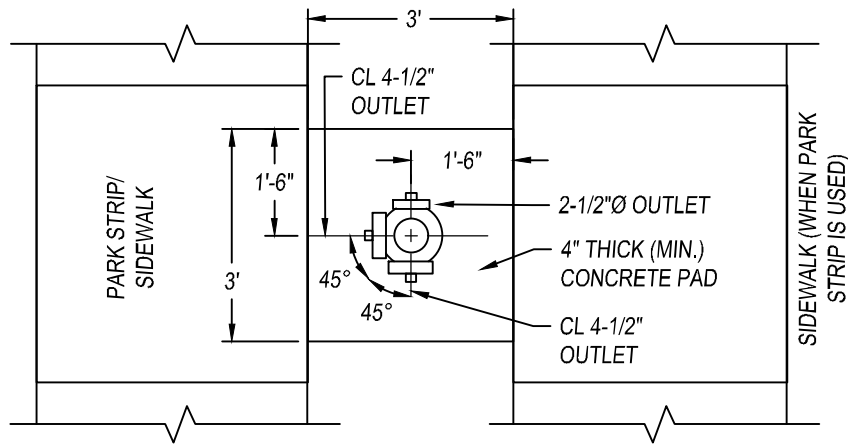

SECTION A-A

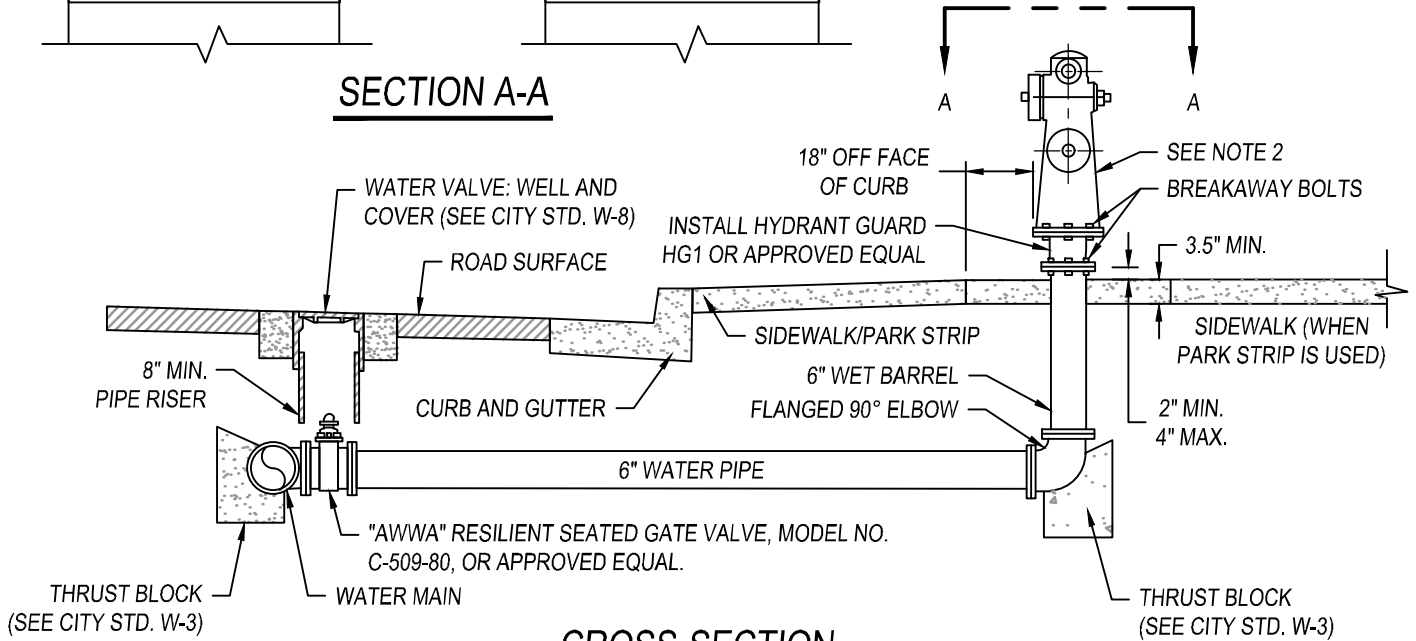

CROSS-SECTION

NOTES:

1. TRADE NAMES ARE SPECIFIED AS STANDARD OF ACCEPTABLE QUALITY AND FEATURES. EQUIPMENT OF EQUAL QUALITY WITH EQUAL FEATURES MAY BE SUBSTITUTED ONLY WRITTEN APPROVAL FROM THE DINUBA FIRE DEPARTMENT.
2. HYDRANTS SHALL BE "CLOW" MODEL 865, WET BARREL, OR APPROVED EQUAL.
3. HYDRANTS SHALL HAVE (2)-4 1/2" DIAMETER OUTLETS AND (1)-2 1/2" DIAMETER OUTLET.
4. NOZZLE CENTERLINES SHALL BE LOCATED NOT LESS THAN 18" ABOVE FINISH GRADE.
5. GATE VALVES SHALL BE "RESILIENT SEAT" TYPE FLANGED TO MAIN LINE.
6. HYDRANT SHALL BE EQUIPPED WITH A HYDRANT GUARD HG1 OR APPROVED EQUAL BETWEEN THE HYDRANT AND RISER.
7. A BLUE TWO-WAY REFLECTIVE MARKER SHALL BE INSTALLED ON THE CENTER LINE OF THE STREET ADJACENT TO THE HYDRANT PER CITY STD. W-6.
8. HYDRANTS SHALL HAVE A 4.5" STORZ HYDRANT ADAPTER (MODEL: HPHA50-45NH/CAP, OR APPROVED EQUAL) ATTACHED TO THE BOTTOM OF THE 4 1/2" DIAMETER OUTLET.
9. HYDRANT SHALL BE PAINTED OSHA SAFETY YELLOW.
10. A 3' DIAMETER OR 3' SQUARE CONCRETE PAD SHALL BE PROVIDED AROUND THE HYDRANT.
11. ALL CAPS AND THREADS SHALL BE LUBRICATED WITH A WATER PROOF GREASE FOLLOWING INSTALLATION. METAL CAPS SHALL BE INSTALLED ON OUTLETS.
12. MAXIMUM DISTANCE BETWEEN FIRE HYDRANTS IS 400' (RESIDENTIAL) AND 300' (COMMERCIAL).
13. PAINT CURB RED FROM CENTERLINE OF FIRE HYDRANT 15' EACH WAY.



CITY COUNCIL APPROVAL: 01/24/2023
 APPROVED BY CITY ENGINEER
 APPROVED BY PUBLIC WORKS DIRECTOR

FIRE HYDRANT INSTALLATION

PUBLIC IMPROVEMENT STANDARDS

W-5

REVISIONS

NAME	BY	DATE

MULTI LANE STREET

LEGEND:

 FIRE HYDRANT

 BLUE RETROREFLECTIVE RAISED PAVEMENT MARKER

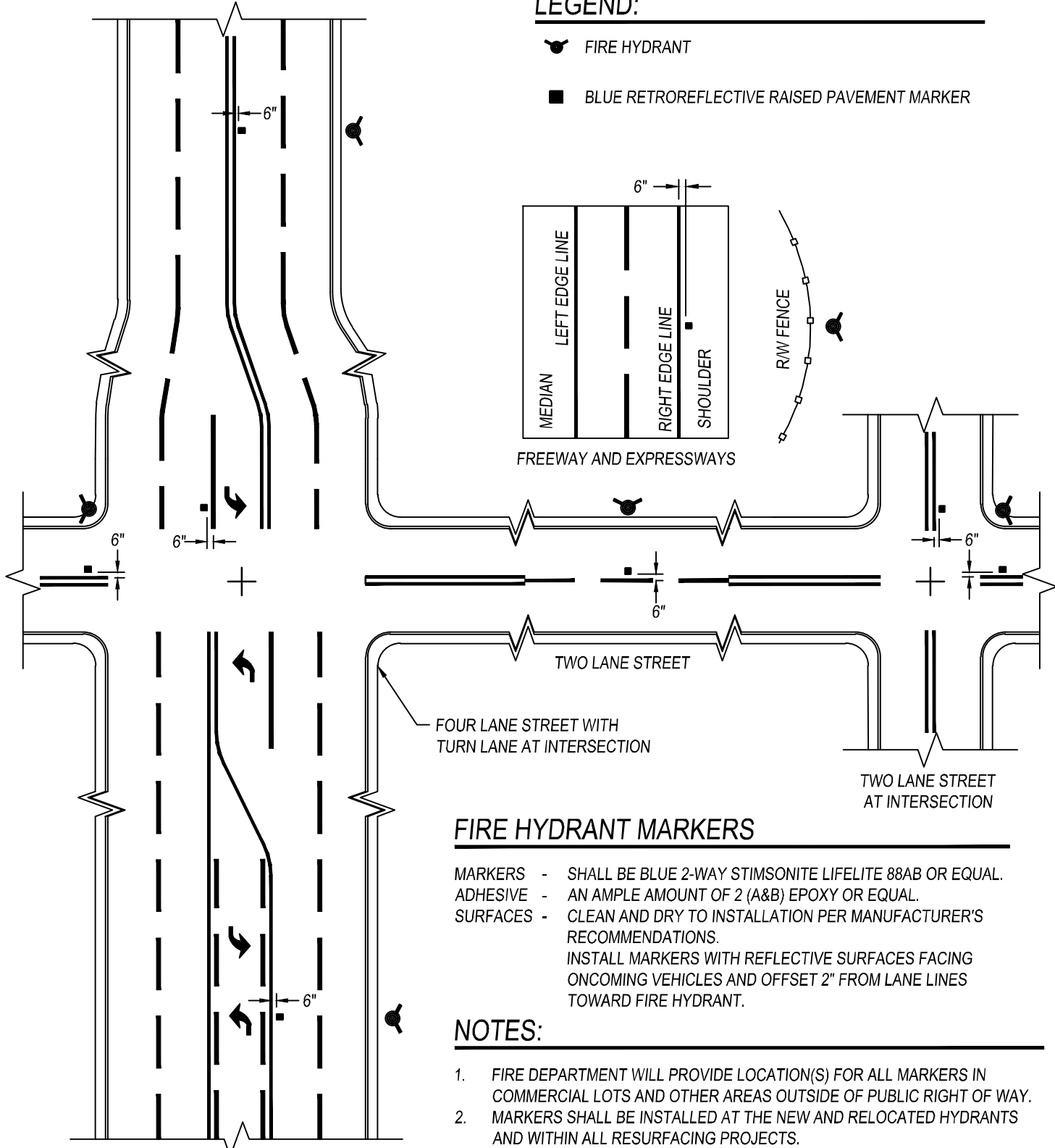

FIRE HYDRANT MARKERS

MARKERS - SHALL BE BLUE 2-WAY STIMSONITE LIFELITE 88AB OR EQUAL.
 ADHESIVE - AN AMPLE AMOUNT OF 2 (A&B) EPOXY OR EQUAL.
 SURFACES - CLEAN AND DRY TO INSTALLATION PER MANUFACTURER'S RECOMMENDATIONS.
 INSTALL MARKERS WITH REFLECTIVE SURFACES FACING ONCOMING VEHICLES AND OFFSET 2" FROM LANE LINES TOWARD FIRE HYDRANT.

NOTES:

1. FIRE DEPARTMENT WILL PROVIDE LOCATION(S) FOR ALL MARKERS IN COMMERCIAL LOTS AND OTHER AREAS OUTSIDE OF PUBLIC RIGHT OF WAY.
2. MARKERS SHALL BE INSTALLED AT THE NEW AND RELOCATED HYDRANTS AND WITHIN ALL RESURFACING PROJECTS.
3. FOR STREETS WITHOUT LANE LINE OR STREETS WITH RAISED PAVEMENT MARKERS AND NO PAINTED LANE LINE, INSTALL MARKERS 6" FROM CENTERLINE OR EXISTING MARKERS.



CITY COUNCIL APPROVAL: 01/24/2023

APPROVED BY CITY ENGINEER
 APPROVED BY PUBLIC WORKS DIRECTOR

FIRE HYDRANT PAVEMENT MARKER LOCATION

PUBLIC IMPROVEMENT STANDARDS

W-6

REVISIONS		
NAME	BY	DATE

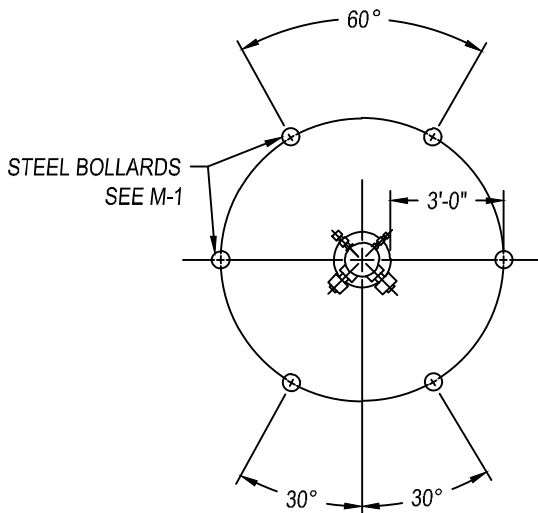
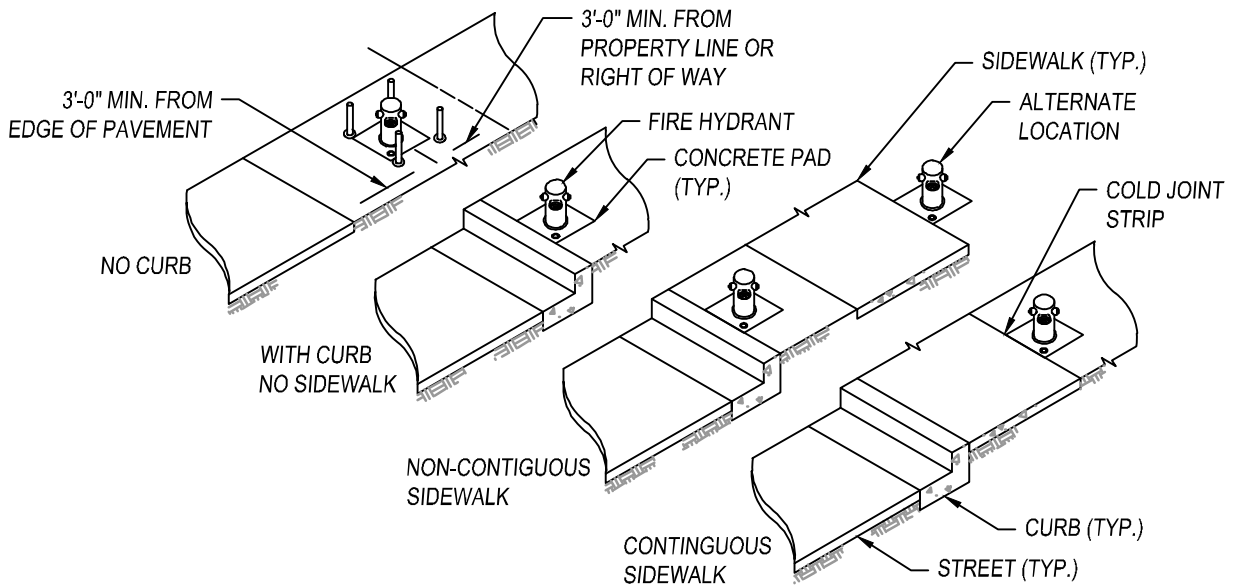

STEEL BOLLARDS

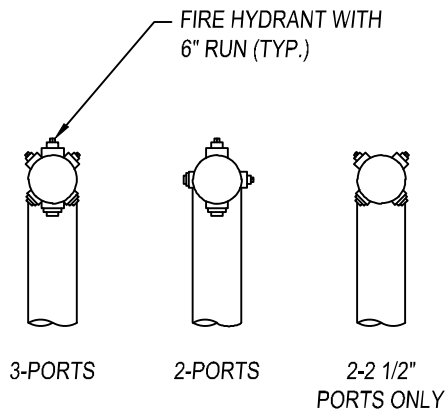

PORT ORIENTATION

NOTES:

1. LOCATE FIRE HYDRANT AS SHOWN ABOVE OR AS DIRECTED BY THE CITY ENGINEER.
2. FIRE HYDRANTS SHALL BE INSTALLED WITH THE LARGEST PORT PERPENDICULAR TO THE STREET.
3. IF THE CONCRETE SLAB IS TO BE INSTALLED ADJACENT TO A CONCRETE CURB OR SIDEWALK, A COLD JOINT STRIP SHALL BE INSTALLED.
4. CONCRETE APRON SHALL BE REQUIRED WHERE THE FIRE HYDRANT IS INSTALLED IN AN UNPAVED LOCATION. THE APRON SHALL BE 4" THICK 520-C-2500 CONCRETE.
5. WHEN DISTANCE FROM THE FIRE HYDRANT TO THE TOP OR TOE OF THE SLOPE OR WALLS IS LESS THAN 2', SPECIAL HYDRANT INSTALLATION DETAIL SHALL BE SHOWN ON THE PLANS.
6. THE DISTANCE FROM THE FACE OF THE CURB TO THE CENTERLINE OF THE FIRE HYDRANT SHALL BE 2 1/2' MINIMUM.
7. WHEN REQUIRED, NUMBER OF BOLLARDS AND LOCATION TO BE SHOWN ON THE PLANS.



CITY COUNCIL APPROVAL: 01/24/2023

APPROVED BY CITY ENGINEER
 APPROVED BY PUBLIC WORKS DIRECTOR

**FIRE HYDRANT LOCATION -
SIDEWALK**

PUBLIC IMPROVEMENT STANDARDS

W-7

REVISIONS

NAME	BY	DATE

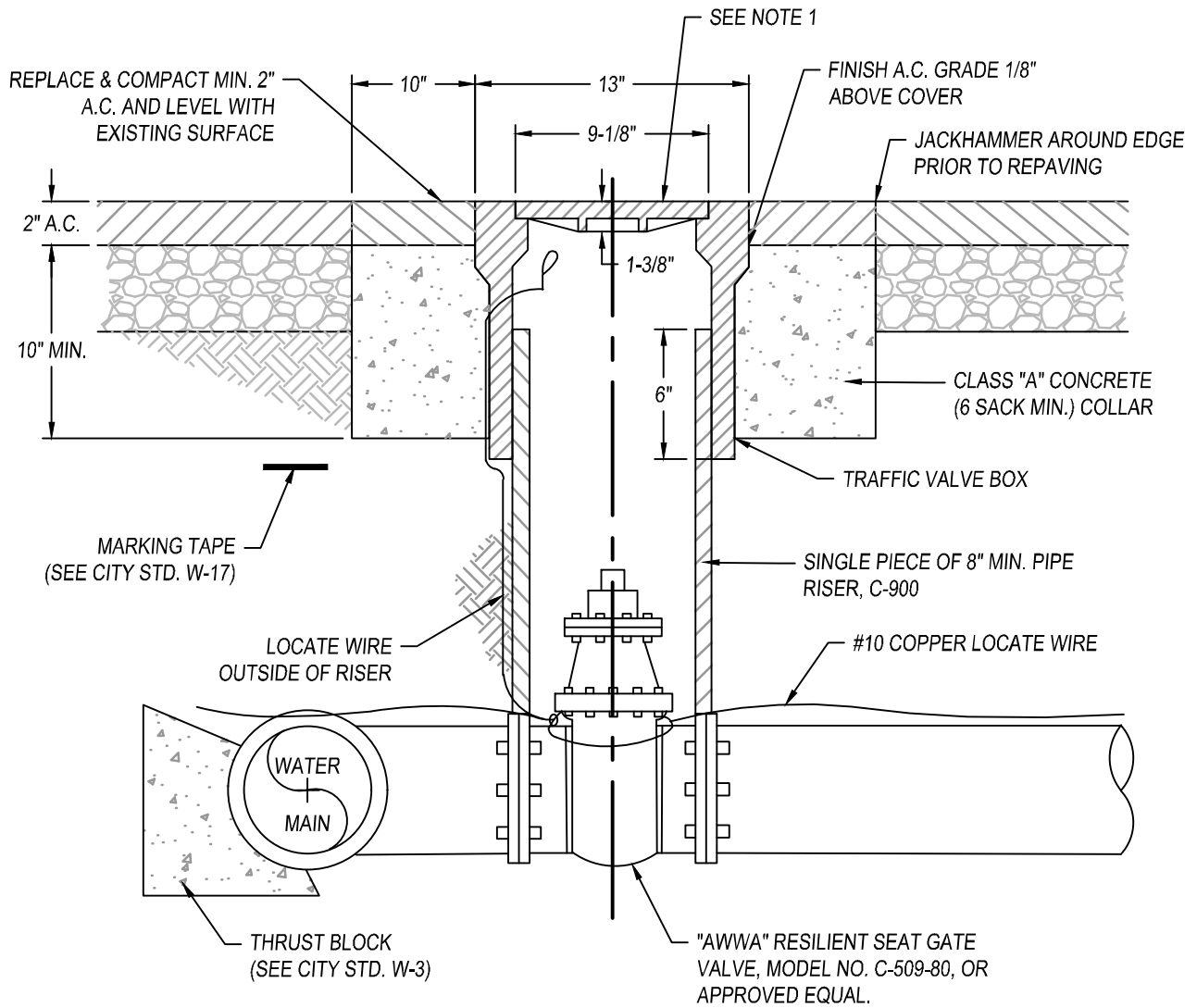

NOTES:

1. CAST IRON COVER WITH STREET TREAD INSCRIBED "WATER".
2. ON FIRE SPRINKLER RUNS, COVER SHALL BE INSCRIBED "FIRE".
3. INSTALL "CHRISTY" G5 TRAFFIC VALVE BOX 13" DIA. X 12", OR APPROVED EQUAL.
4. MAXIMUM DISTANCE BETWEEN IN-LINE GATE VALVES IS 500 FT., OR INTERSECTION PER PLANS.
5. WRAP ALL VALVES AND FITTINGS IN 8 MIL. PLASTIC WITH 10 MIL. TAPE.

APPROVED GATE VALVES:

- "KENNEDY"
- "M & H DRESSER"
- "MUELLER"
- "CLOW"



CITY COUNCIL APPROVAL: 01/24/2023
 APPROVED BY CITY ENGINEER
 APPROVED BY PUBLIC WORKS DIRECTOR

WATER VALVE, WELL, AND COVER

PUBLIC IMPROVEMENT STANDARDS

W-8

REVISIONS

NAME	BY	DATE

LEGEND

 GALVANIZED STEEL PIPE

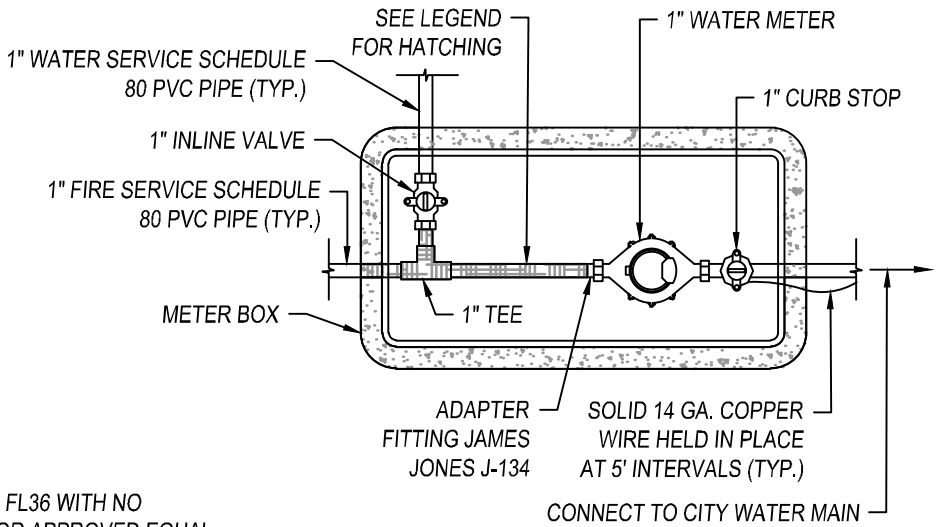

WATER METER PLAN VIEW

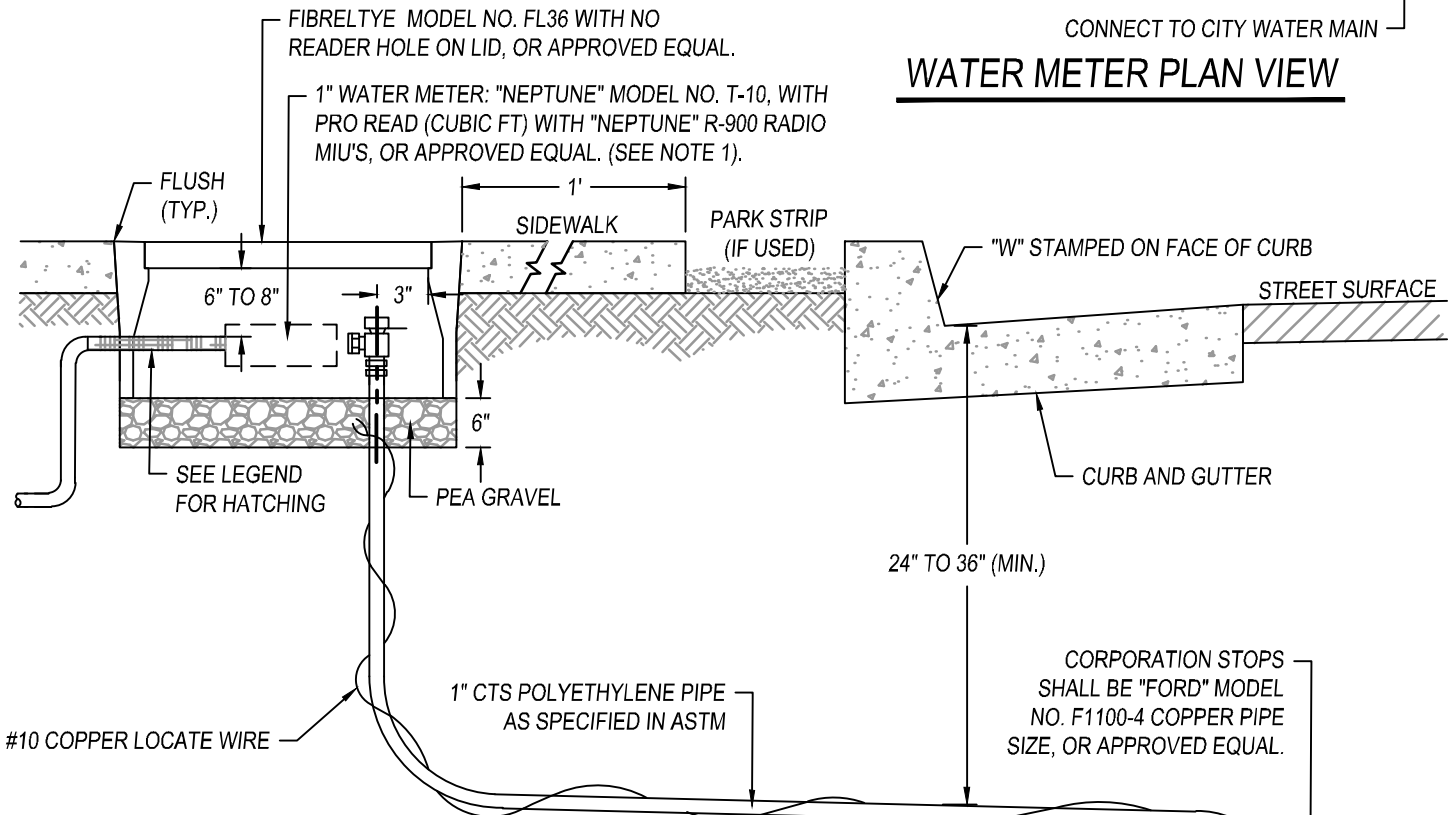

NOTES:

1. WATER METERS WILL BE FURNISHED AND INSTALLED BY THE PUBLIC WORKS DEPARTMENT. INSTALLATION FEES SHALL BE PAID PRIOR TO SETTING THE METER.
2. ALL SERVICES WITH A METER SHALL BE SUPPLIED WITH A BOX AND WITH A LID MARKED "WATER" (NO CONCRETE BOXES OR LIDS).
3. METERS SHALL BE THE "COLD DISPLACEMENT" TYPE WATER METER CONFORMING TO "AWWA" STD. C700, OR APPROVED EQUAL.
4. WATER METER & BOXES SHALL BE INSTALLED WITHIN THE SIDEWALK, AND NOT WITHIN THE DRIVE APPROACH.
5. ALL GALVANIZED PIPE SHALL BE WRAPPED IN A 10 MIL PIPE WRAP TAPE.

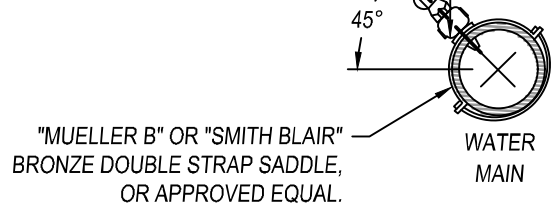

CITY COUNCIL APPROVAL: 01/24/2023
 APPROVED BY CITY ENGINEER
 APPROVED BY PUBLIC WORKS DIRECTOR

1" RESIDENTIAL WATER SERVICE PUBLIC IMPROVEMENT STANDARDS

W-9		
REVISIONS		
NAME	BY	DATE

LEGEND

 GALVANIZED STEEL PIPE

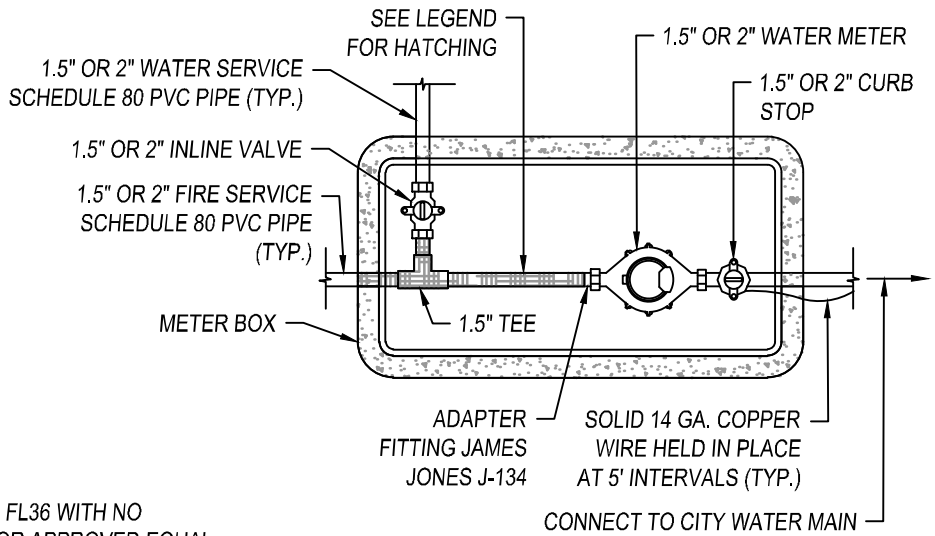

WATER METER PLAN VIEW

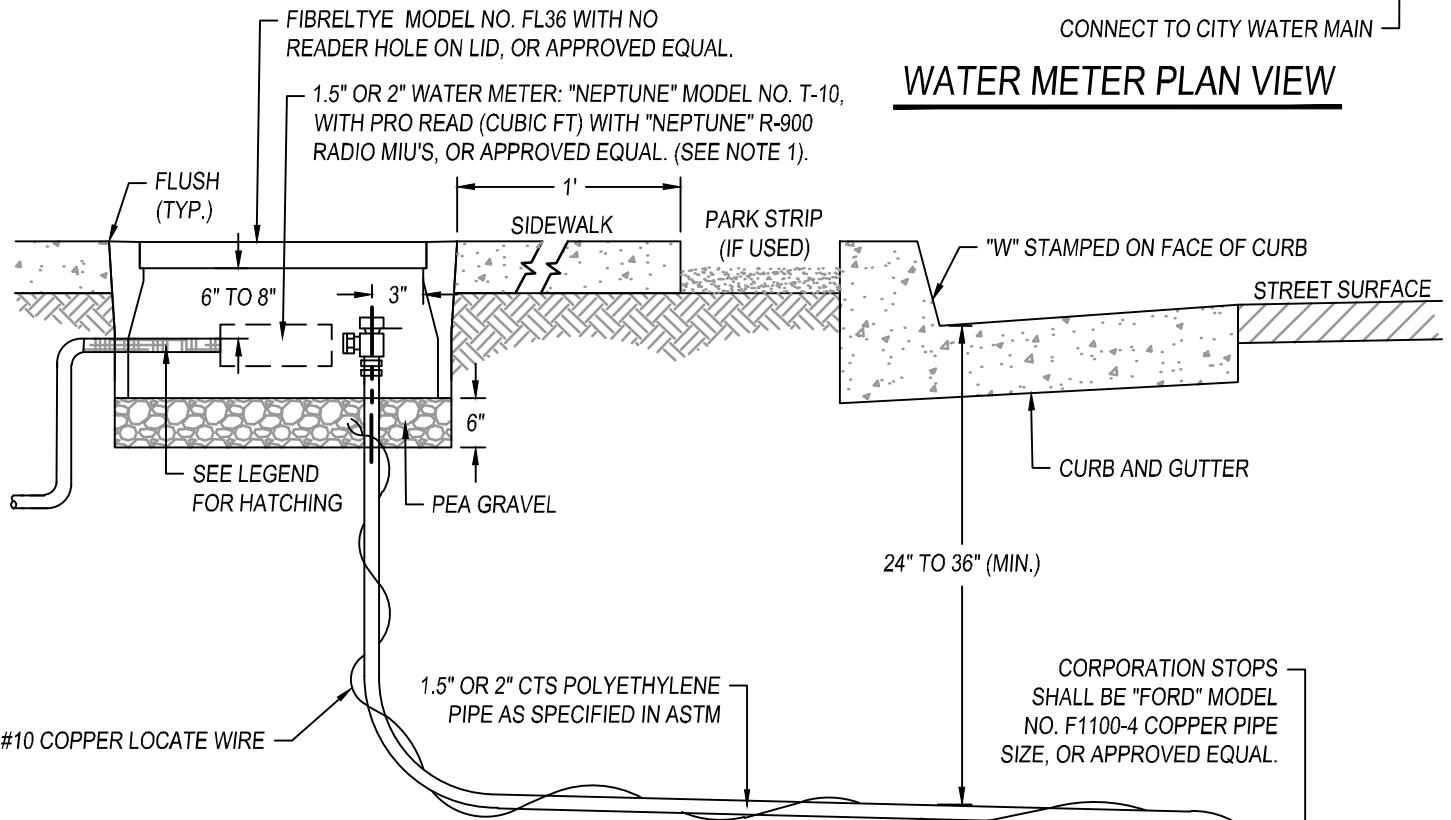

NOTES:

1. WATER METERS WILL BE FURNISHED AND INSTALLED BY THE PUBLIC WORKS DEPARTMENT. INSTALLATION FEES SHALL BE PAID PRIOR TO SETTING THE METER.
2. ALL SERVICES WITH A METER SHALL BE SUPPLIED WITH A BOX AND WITH A LID MARKED "WATER" (NO CONCRETE BOXES OR LIDS).
3. METERS SHALL BE THE "COLD DISPLACEMENT" TYPE WATER METER CONFORMING TO "AWWA" STD. C700, OR APPROVED EQUAL.
4. WATER METER & BOXES SHALL BE INSTALLED WITHIN THE SIDEWALK, AND NOT WITHIN THE DRIVE APPROACH.
5. ALL GALVANIZED PIPE SHALL BE WRAPPED IN A 10MIL PIPE WRAP TAPE.

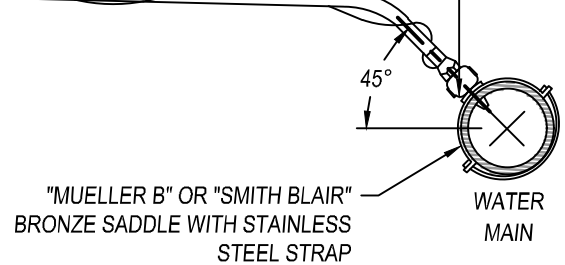

CITY COUNCIL APPROVAL: 01/24/2023

[Signature]
APPROVED BY CITY ENGINEER

[Signature]
APPROVED BY PUBLIC WORKS DIRECTOR

1.5" & 2" RESIDENTIAL WATER SERVICE

PUBLIC IMPROVEMENT STANDARDS

W-10

REVISIONS

NAME	BY	DATE

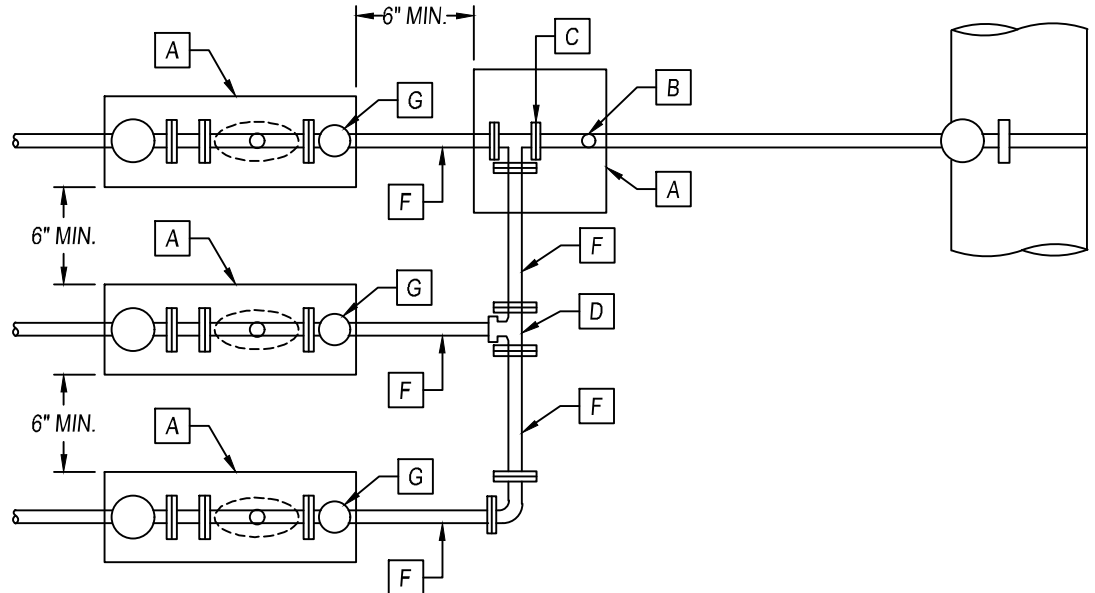
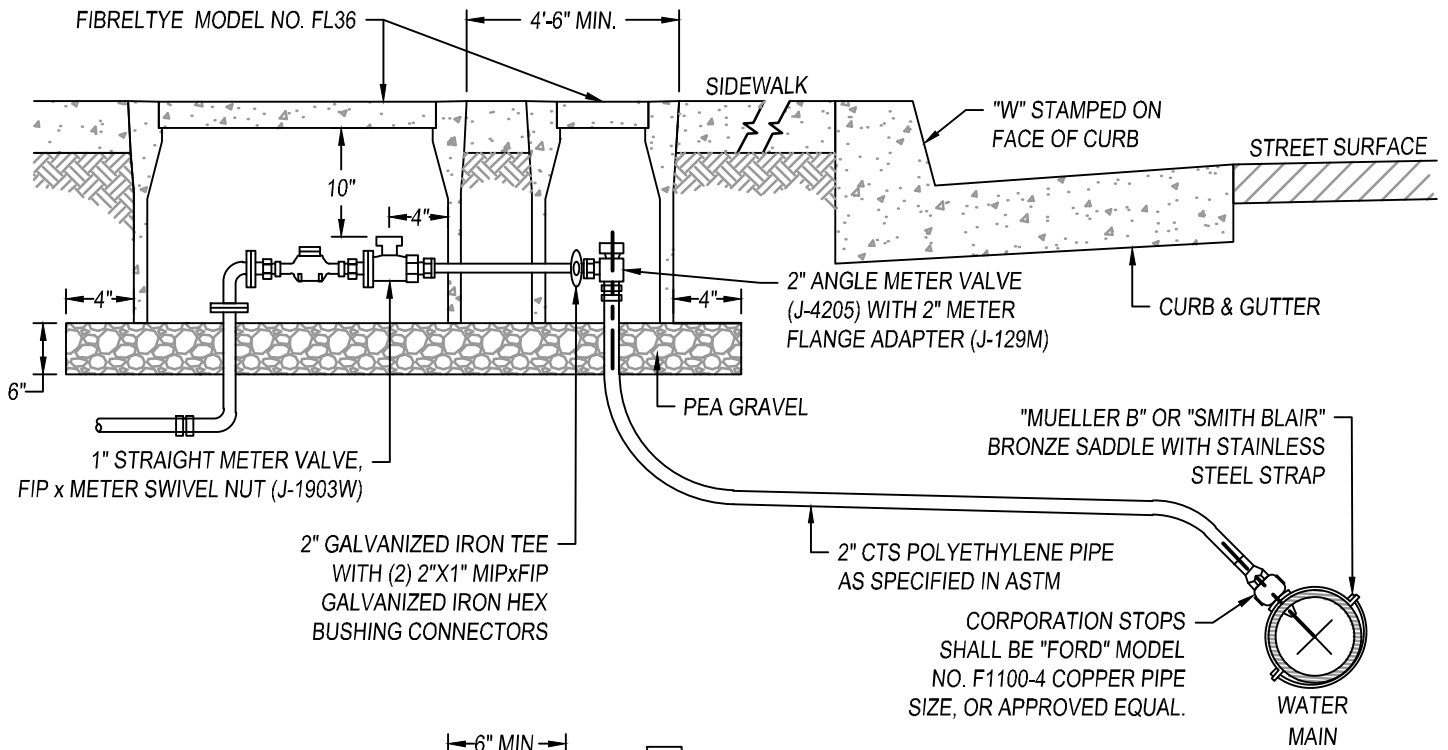

LEGEND

- A. FIBRELTYE MODEL NO. FL36
- B. 2" ANGLE METER VALVE (J-4205) WITH 2" METER FLANGE ADAPTER (J-129M)
- C. 2" GALVANIZED IRON TEE WITH (2) 2"x1" MIPxFIP GALVANIZED IRON HEX BUSHING CONNECTORS
- D. 1" GALVANIZED IRON TEE (FIP x FIP x FIP)
- E. 1" GALVANIZED IRON ELBOW (FIP x FIP)
- F. 1" DIA., GALVANIZED IRON PIPE
- G. 1" STRAIGHT METER VALVE, FIP x METER SWIVEL NUT (J-1903W)

NOTES:

1. PARTS NUMBER PRECEDED WITH J ARE JAMES JONES CO..
2. 5/8" DISPLACEMENT TYPE MAGNETIC DRIVE STRAIGHT READING GALLONS.
3. METER BOX NOT TO BE INSTALLED IN SIDEWALK/DRIVE APPROACH.
4. BOXES IN ALLEYS SUBJECT TO TRAFFIC LOADS SHALL HAVE TRAFFIC RATED LIDS & BOXES AS DIRECTED BY THE ENGINEER.
5. ALL GALVANIZED PIPE SHALL BE WRAPPED IN A 10MIL PIPE WRAP TAPE.



CITY COUNCIL APPROVAL: 01/24/2023

APPROVED BY CITY ENGINEER
 APPROVED BY PUBLIC WORKS DIRECTOR

**COMMERCIAL 3-MANIFOLD
 WATER SERVICE**

PUBLIC IMPROVEMENT STANDARDS

W-11

REVISIONS		
NAME	BY	DATE

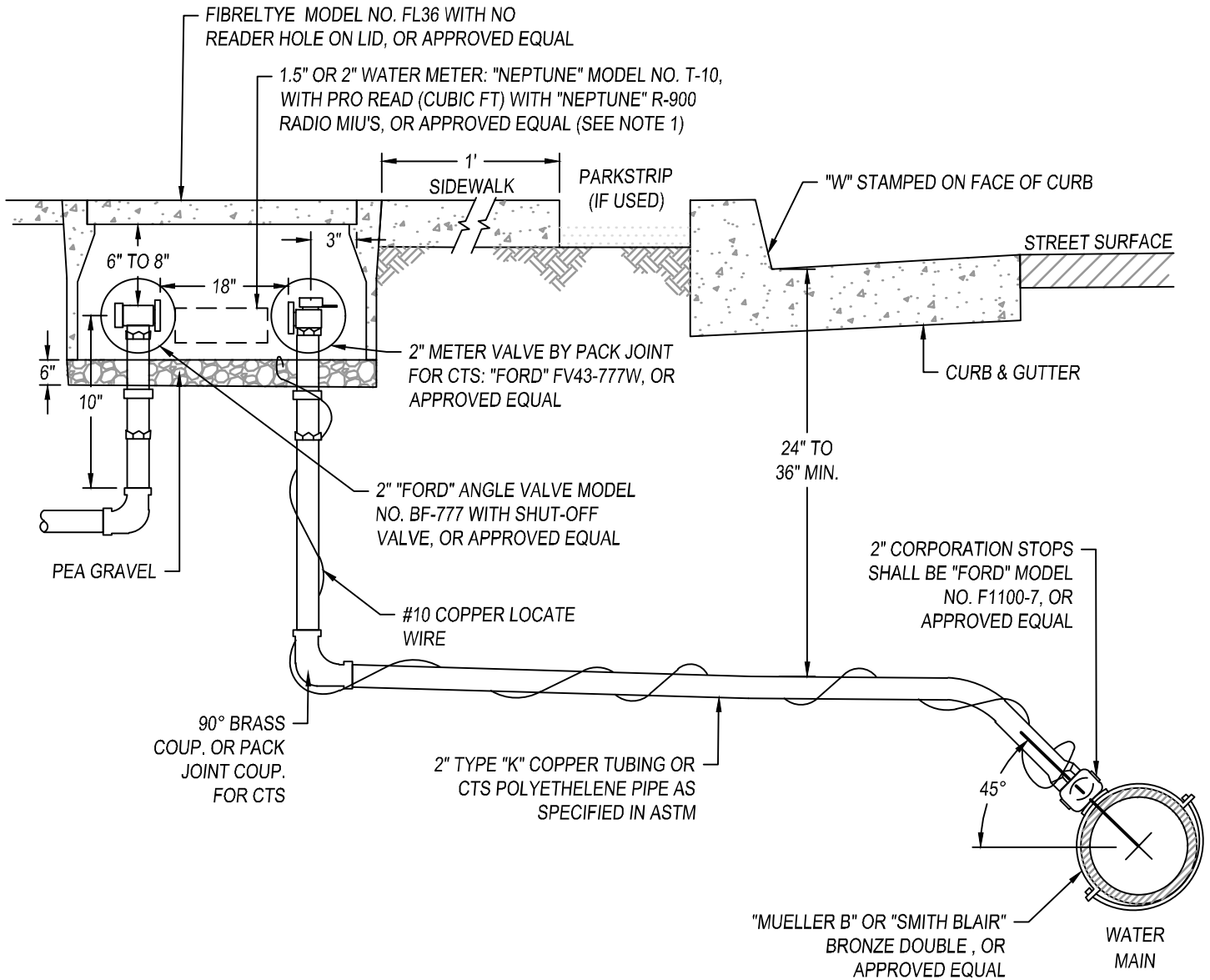

NOTES:

1. WATER METERS WILL BE FURNISHED AND INSTALLED BY THE PUBLIC WORKS DEPARTMENT. INSTALLATION FEES SHALL BE PAID PRIOR TO SETTING THE METER.
2. ALL SERVICES WITH A METER SHALL BE SUPPLIED WITH A BOX AND WITH A LID MARKED "WATER" (NO CONCRETE BOXES OR LIDS).
3. METERS SHALL BE THE "COLD DISPLACEMENT" TYPE WATER METER CONFORMING TO "AWWA" STD. C700, OR APPROVED EQUAL.
4. WATER METER & BOXES SHALL BE INSTALLED WITHIN THE SIDEWALK, AND NOT WITHIN THE DRIVE APPROACH.
6. ALL GALVANIZED PIPE SHALL BE WRAPPED IN A 10MIL PIPE WRAP TAPE.



CITY COUNCIL APPROVAL: 01/24/2023
 APPROVED BY CITY ENGINEER
 APPROVED BY PUBLIC WORKS DIRECTOR

2" COMMERCIAL WATER SERVICE

PUBLIC IMPROVEMENT STANDARDS

W-12

REVISIONS

NAME	BY	DATE

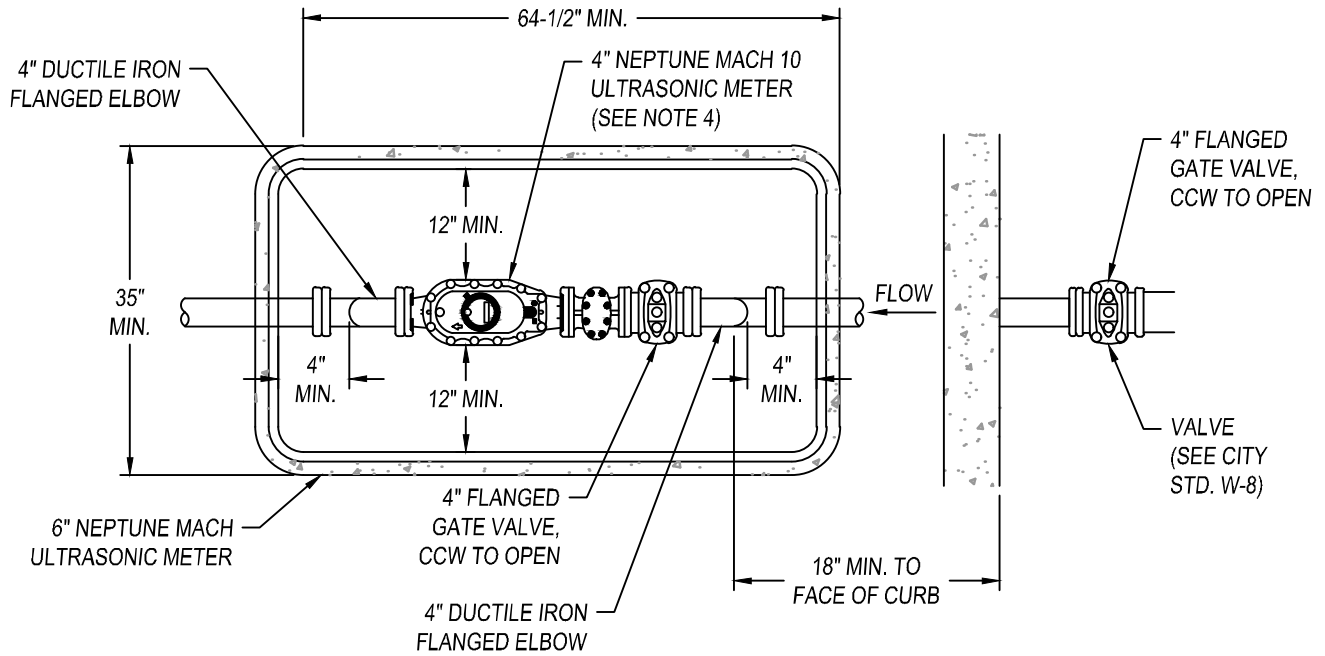

PLAN VIEW

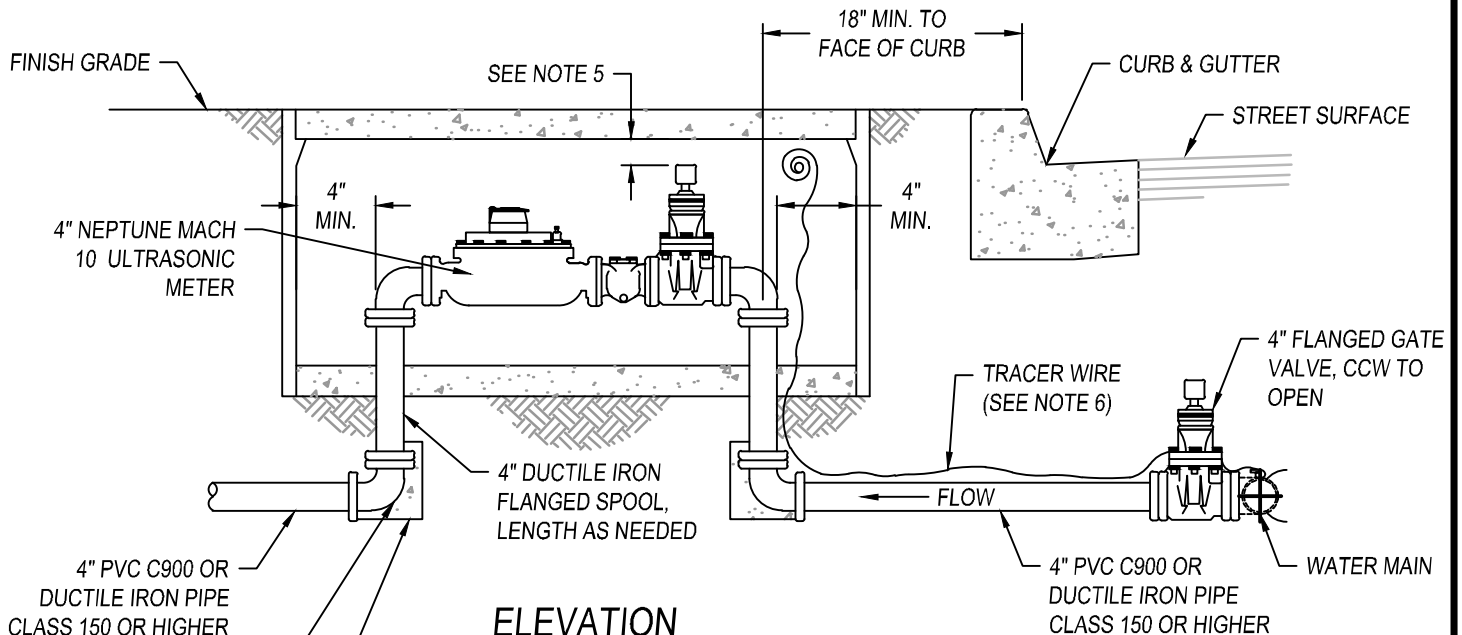

ELEVATION

NOTES:

1. VALVES TO BE MUELLER A-2360 OR EQUAL WITH 2" SQUARE NUTS, CCW TO OPEN.
2. 6" SEAL/BENCH WITH CONCRETE INSIDE OF VAULTS.
3. METER BOX IN SIDEWALK OR PLACE 3-1/2" THICK CL2 CONCRETE SLAB, 1' ON ALL SIDES OF BOX.
4. 23-1/4" GALVANIZED SPACER SHALL BE INSTALLED.
5. TOP OF OPERATIVE SQUARE NUT TO BE 4" MIN. TO 12" MAX. BELOW BOTTOM OF LID.
6. TRACER WIRE TO BE #10 STRANDED COPPER WITH WHITE INSULATION.



CITY COUNCIL APPROVAL: 01/24/2023
 APPROVED BY CITY ENGINEER
 APPROVED BY PUBLIC WORKS DIRECTOR

4" COMMERCIAL WATER SERVICE

PUBLIC IMPROVEMENT STANDARDS

W-13

REVISIONS

NAME	BY	DATE

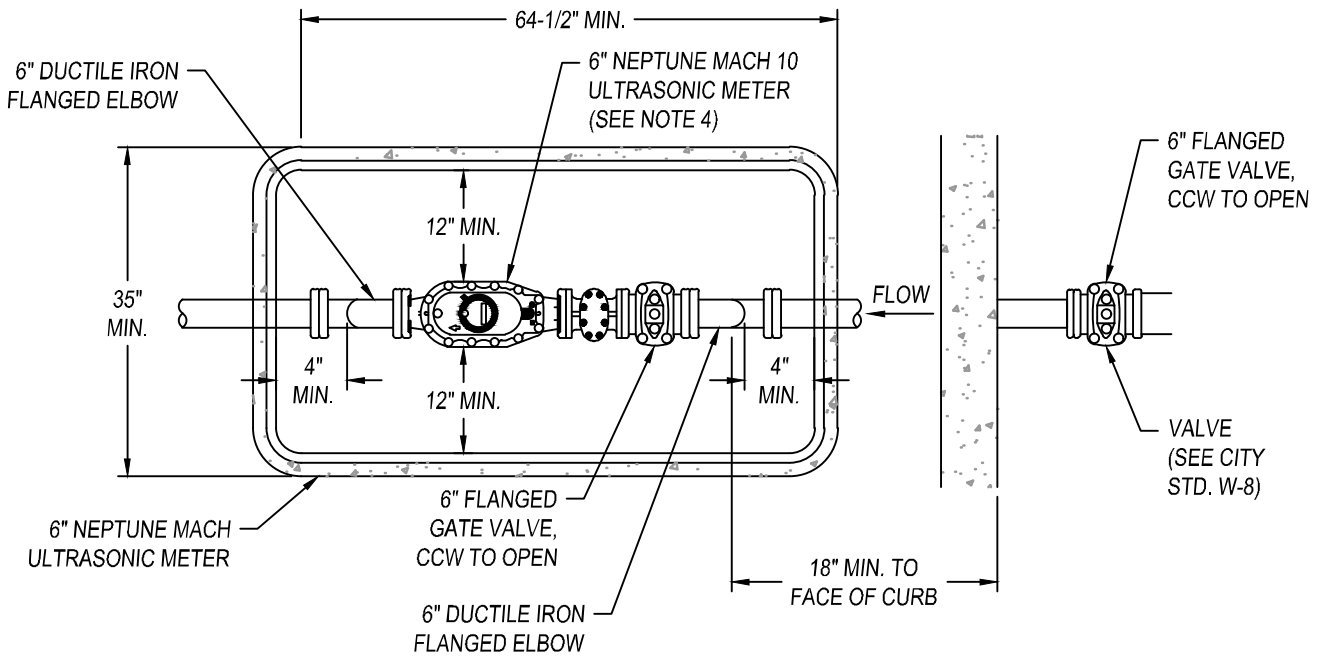

PLAN VIEW

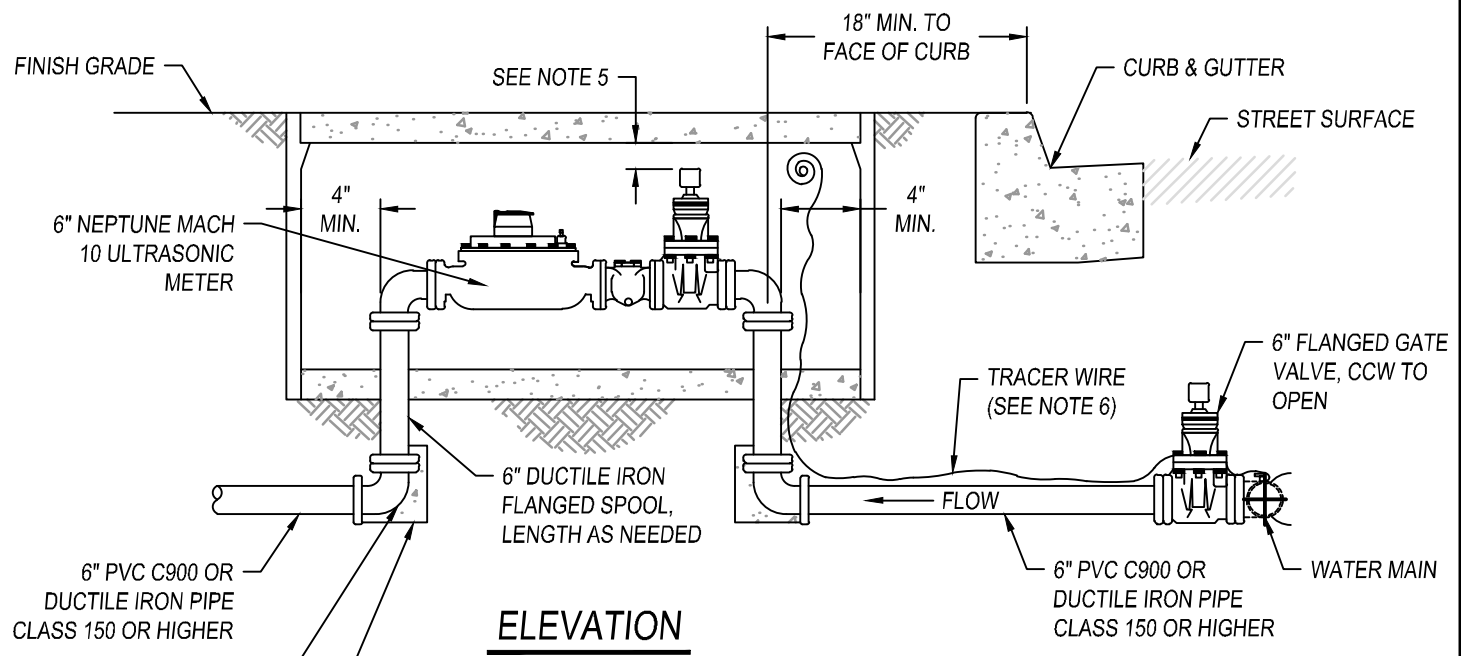

ELEVATION

NOTES:

1. VALVES TO BE MUELLER A-2360 OR EQUAL WITH 2" SQUARE NUTS, CCW TO OPEN.
2. 6" SEAL/BENCH WITH CONCRETE INSIDE OF VAULTS.
3. METER BOX IN SIDEWALK OR PLACE 3-1/2" THICK CL2 CONCRETE SLAB, 1' ON ALL SIDES OF BOX.
4. 27-1/4" GALVANIZED SPACER SHALL BE INSTALLED.
5. TOP OF OPERATIVE SQUARE NUT TO BE 4" MIN. TO 12" MAX. BELOW BOTTOM OF LID.
6. TRACER WIRE TO BE #10 STRANDED COPPER WITH WHITE INSULATION.



CITY COUNCIL APPROVAL: 01/24/2023

APPROVED BY CITY ENGINEER

APPROVED BY PUBLIC WORKS DIRECTOR

6" COMMERCIAL WATER SERVICE

PUBLIC IMPROVEMENT STANDARDS

W-14		
REVISIONS		
NAME	BY	DATE

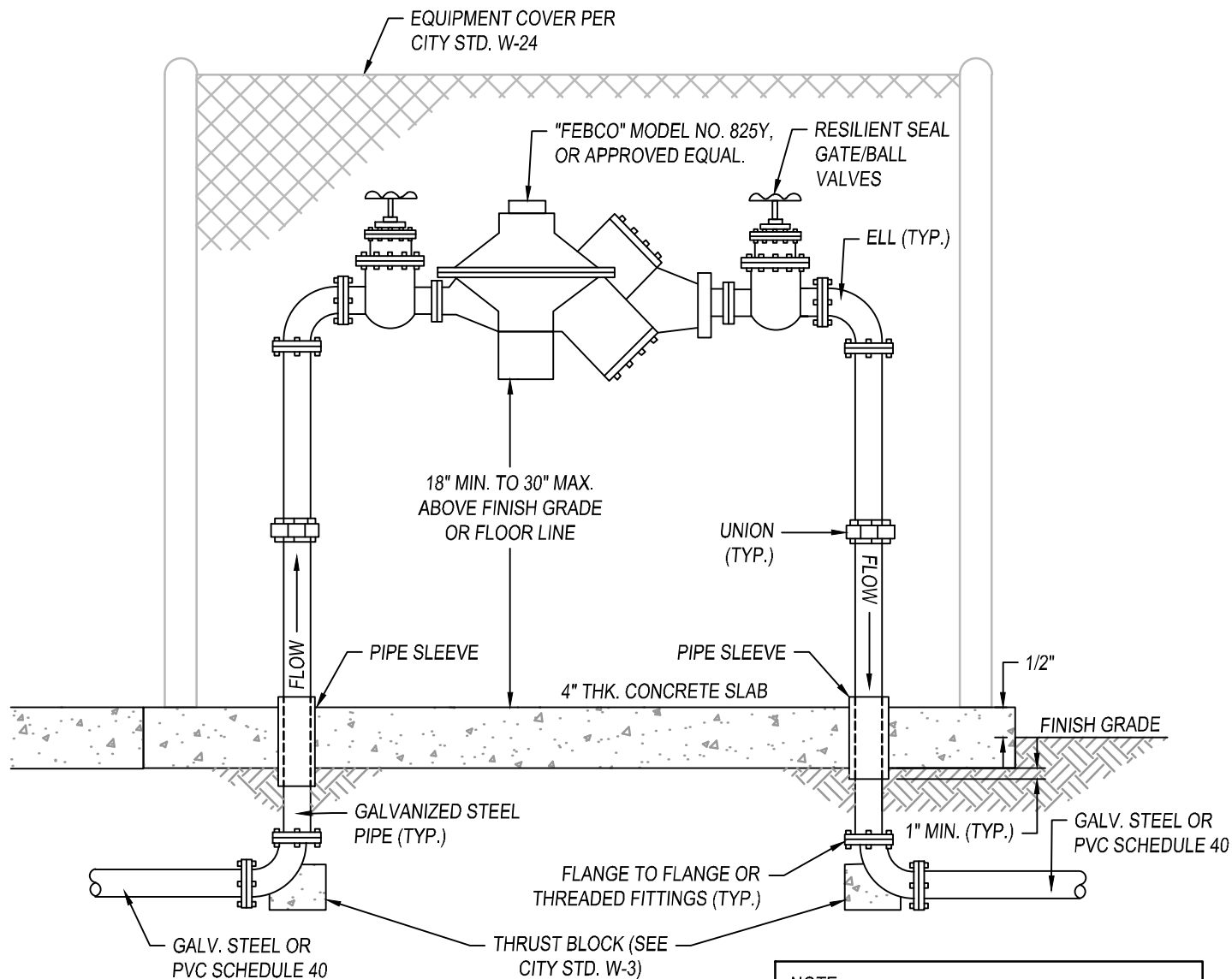

NOTE:
 THE BACKFLOW PREVENTION ASSEMBLY SHALL BE TESTED AND APPROVED BY AN APPROVED AWWA OR ABPA CERTIFIED TESTER WITHIN FIVE (5) DAYS OF INSTALLATION WITH THE RESULTS SENT TO THE CITY OF DINUBA.

NOTES:

1. ALL PIPE FITTINGS SHALL BE PVC SCHEDULE 40, OR GALVANIZED STEEL, UNLESS OTHERWISE SPECIFIED.
2. BACKFLOW PREVENTER DEVICE AND INSTALLATION SHALL BE APPROVED AND INSPECTED BY THE PUBLIC WORKS DEPARTMENT.
3. VALVE ASSEMBLIES MAY HAVE SCREWED FITTINGS OR FLANGED FITTINGS.
4. COAT ALL EXPOSED THREADS WITH AN APPROVED RUST INHIBITING SEALANT.
5. APPROVED PLASTIC TAPE, 1/2" WIDE, SHALL BE USED ON ALL THREADED CONNECTIONS.
6. DISSIMILAR METALS SHALL BE SEPARATED BY AN APPROVED DIELECTRIC COUPLING.
7. PLASTIC PIPE SHALL NOT BE USED ABOVE FINISH GRADE.
8. CONTRACTOR SHALL PROVIDE ADJUSTABLE PIPE SUPPORT APPROVED BY CITY ENGINEER.
9. PROVIDE 24" MIN. CLEAR SPACE AROUND BLACKFLOW PREVENTER OR AT THE PUBLIC WORKS INSPECTOR DISCRETION.



CITY COUNCIL APPROVAL: 01/24/2023
 APPROVED BY CITY ENGINEER
 APPROVED BY PUBLIC WORKS DIRECTOR

**3/4" TO 2" REDUCED PRESSURE
 PRINCIPAL BACKFLOW PREVENTERS
 PUBLIC IMPROVEMENT STANDARDS**

W-15		
REVISIONS		
NAME	BY	DATE

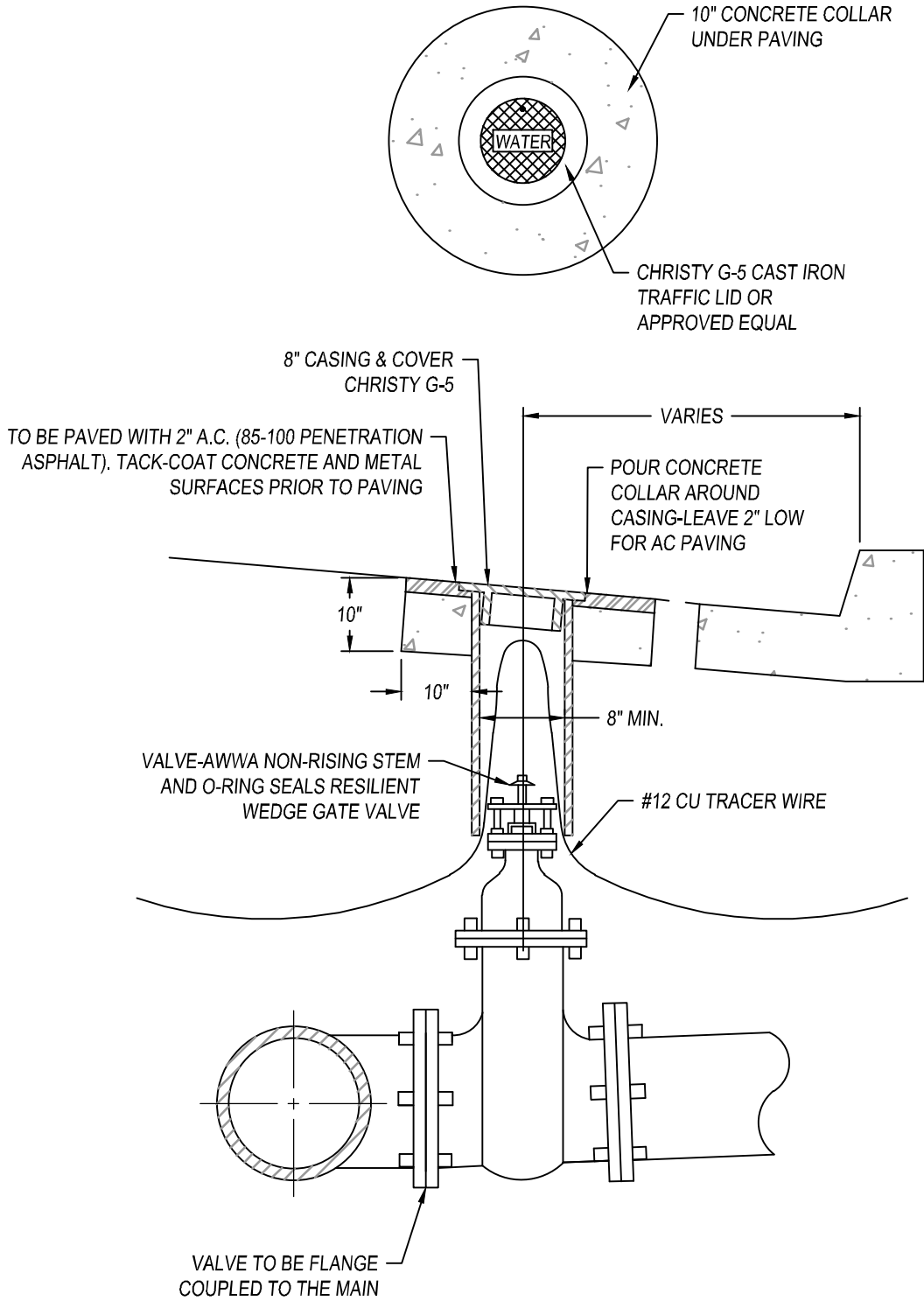

CITY COUNCIL APPROVAL: 01/24/2023



[Signature]
APPROVED BY CITY ENGINEER

[Signature]
APPROVED BY PUBLIC WORKS DIRECTOR

WATER VALVE

PUBLIC IMPROVEMENT STANDARDS

W-16

REVISIONS

NAME	BY	DATE

TRENCH WIDTH

FOR 8" PIPE = 22" TO 32"
 FOR 10" PIPE = 24" TO 34"
 FOR 12" PIPE = 26" TO 36"
 FOR 14" PIPE = 28" TO 36"
 FOR 16" PIPE = 48" TO 60"
 FOR 48" PIPE = 96" TO 102"

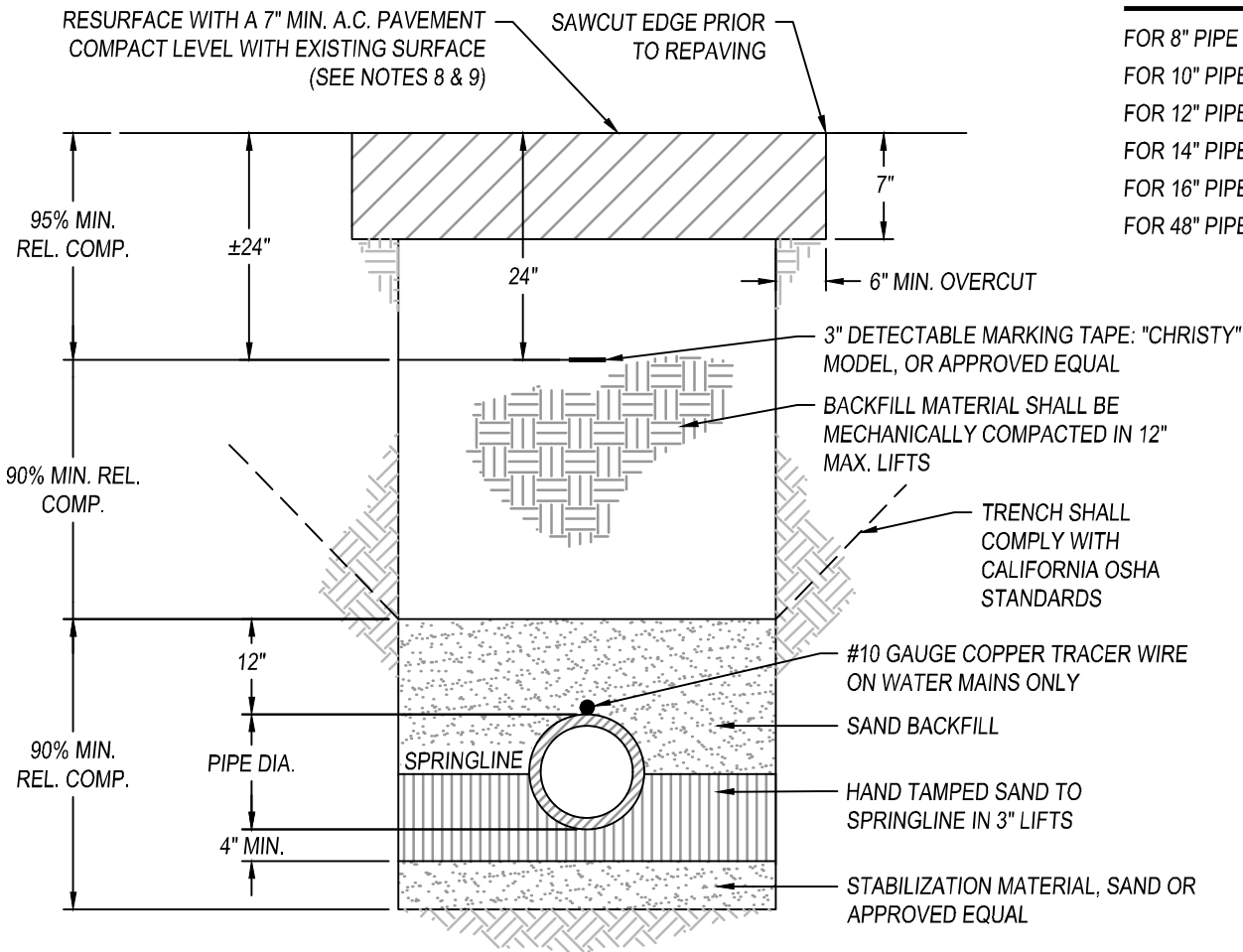

WATER, SANITARY SEWER, AND STORM DRAIN MAINS

8" (MIN.) THRU 12" PIPE = 42" (MIN.) COVER
 OVER 12" PIPE = 48" (MIN.) COVER

NOTES:

- USE SPECIAL CARE IN BEDDING FLEXIBLE PIPE TO ENSURE SIDEWALL SUPPORT.
- LESS COVER FOR 8" PIPE MAY BE ALLOWED AT THE DISCRETION OF THE CITY ENGINEER.
- TRACER WIRE TO BE INSTALLED ON ALL WATER MAINS, WATER SERVICES, AND HYDRANT LATERALS.
- WHEN UNSTABLE SOIL IS ENCOUNTERED CONTRACTOR SHALL PERFORM TRENCHING ACTIVITIES PER CALIFORNIA OSHA STANDARDS.
- JETTING OF TRENCHES IS STRICTLY PROHIBITED.
- MINIMUM WATER MAIN SIZE SHALL BE 8". MINIMUM SEWER MAIN SIZE SHALL BE 8". MINIMUM STORM DRAIN MAIN SIZE SHALL BE 18".
- NEWLY CONSTRUCTED SEWER AND STORM DRAIN MAINS SHALL BE WAYNE BALLED, MANDREL, AIR TESTED AND VIDEO INSPECTED. ALL TESTING SHALL BE OVER SEEN BY A CITY REPRESENTATIVE.
- PERMANENT RESURFACING OF PAVEMENT AREAS SHALL CONSIST OF 7" A.C. PAVING OR MATCH EXISTING PAVEMENT SECTION IF PAVEMENT CUT IS WIDER THAN 6" UNLESS OTHERWISE APPROVED BY THE CITY ENGINEER. EXISTING PAVEMENT CUT EDGES SHALL BE SAWCUT AND TACK COAT SHALL BE APPLIED PRIOR TO FINAL PAVING.
- UNLESS OTHERWISE DIRECTED BY THE CITY ENGINEER, ALL CUTS MADE IN PAVEMENT 5 YEARS AND YOUNGER SHALL BE TREATED WITH THE INFRARED PAVEMENT REPAIR PROCESS A MIN. OF 6" ON EACH SIDE OF SAWCUT. FOR PAVEMENT CUTS LESS THAN 2' IN WIDTH, THE INFRARED PAVEMENT REPAIR SHALL BE APPLIED TO THE ENTIRE AREA. WHEN INFRARED PAVEMENT REPAIR IS NOT REQUIRED, A CRACK SEALANT SHALL BE APPLIED ALONG THE PAVEMENT CUTS.



CITY COUNCIL APPROVAL: 01/24/2023

APPROVED BY CITY ENGINEER
 APPROVED BY PUBLIC WORKS DIRECTOR

TRENCH DETAIL

PUBLIC IMPROVEMENT STANDARDS

W-17

REVISIONS

NAME BY DATE

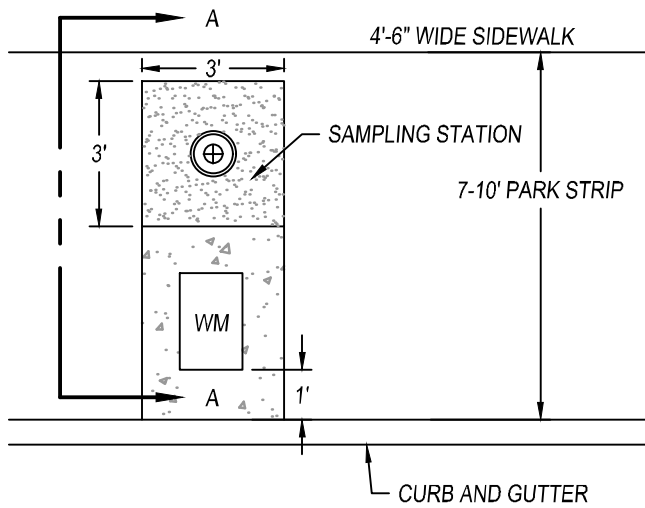

TOP VIEW WITH PARK STRIP

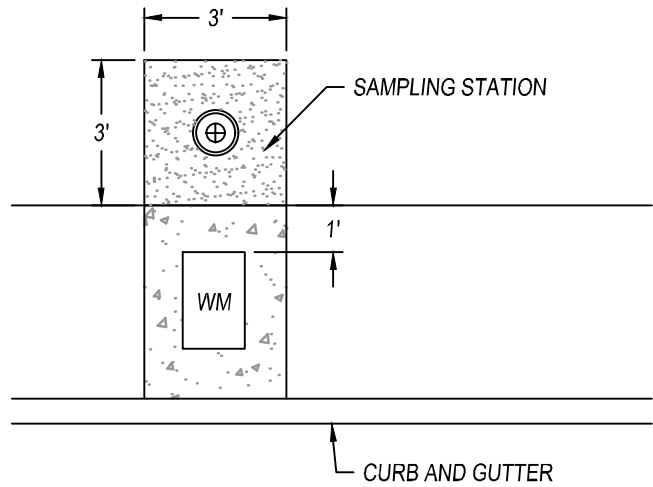

TOP VIEW WITHOUT PARK STRIP

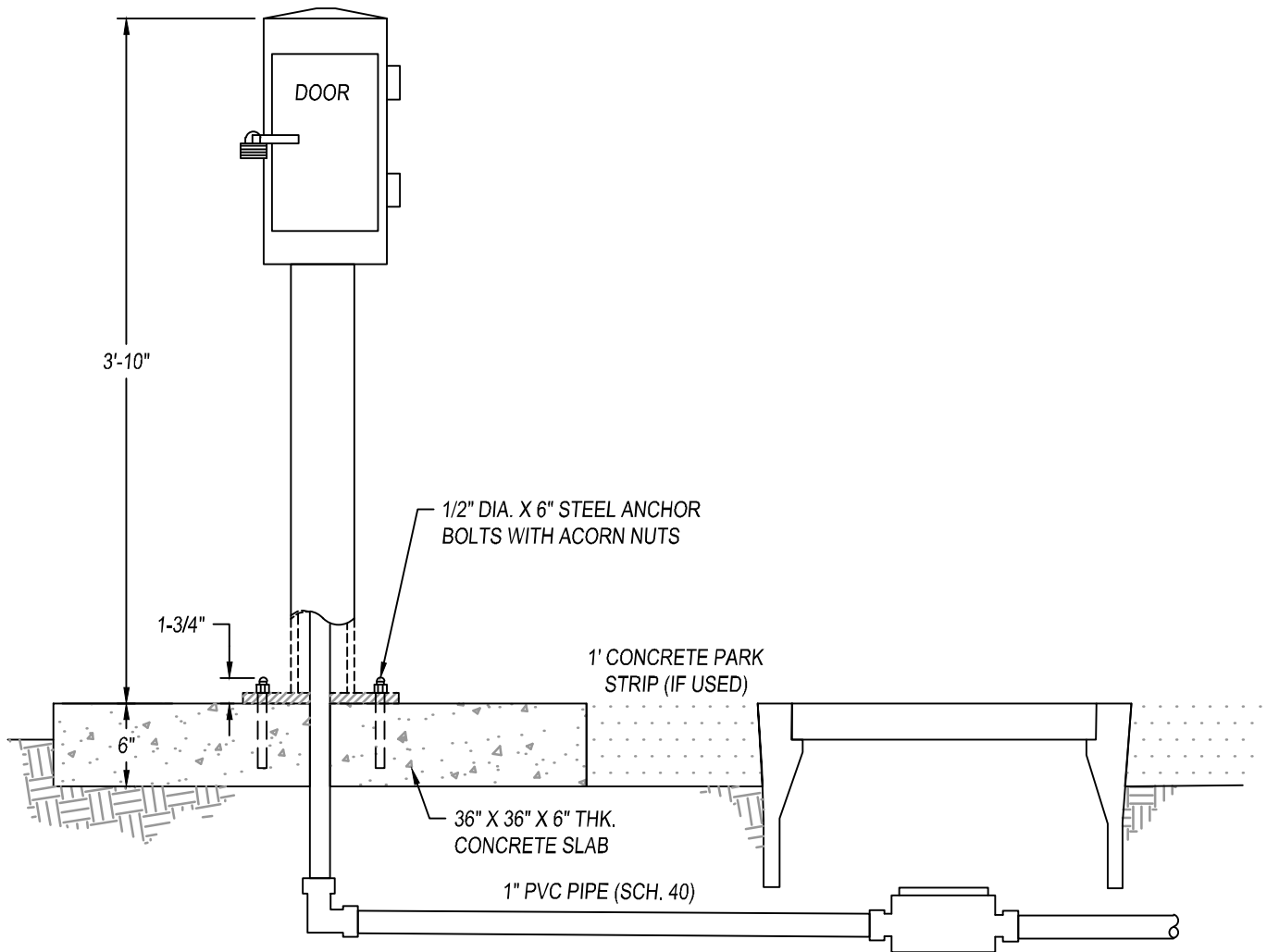

SECTION A-A



CITY COUNCIL APPROVAL: 01/24/2023
 APPROVED BY CITY ENGINEER
 APPROVED BY PUBLIC WORKS DIRECTOR

**WATER SAMPLE STATION
 (SHEET 1 OF 2)**

PUBLIC IMPROVEMENT STANDARDS

W-18

REVISIONS		
NAME	BY	DATE

DOOR TO BE MOUNTED
OPPOSITE FROM
VEHICULAR TRAFFIC AREA

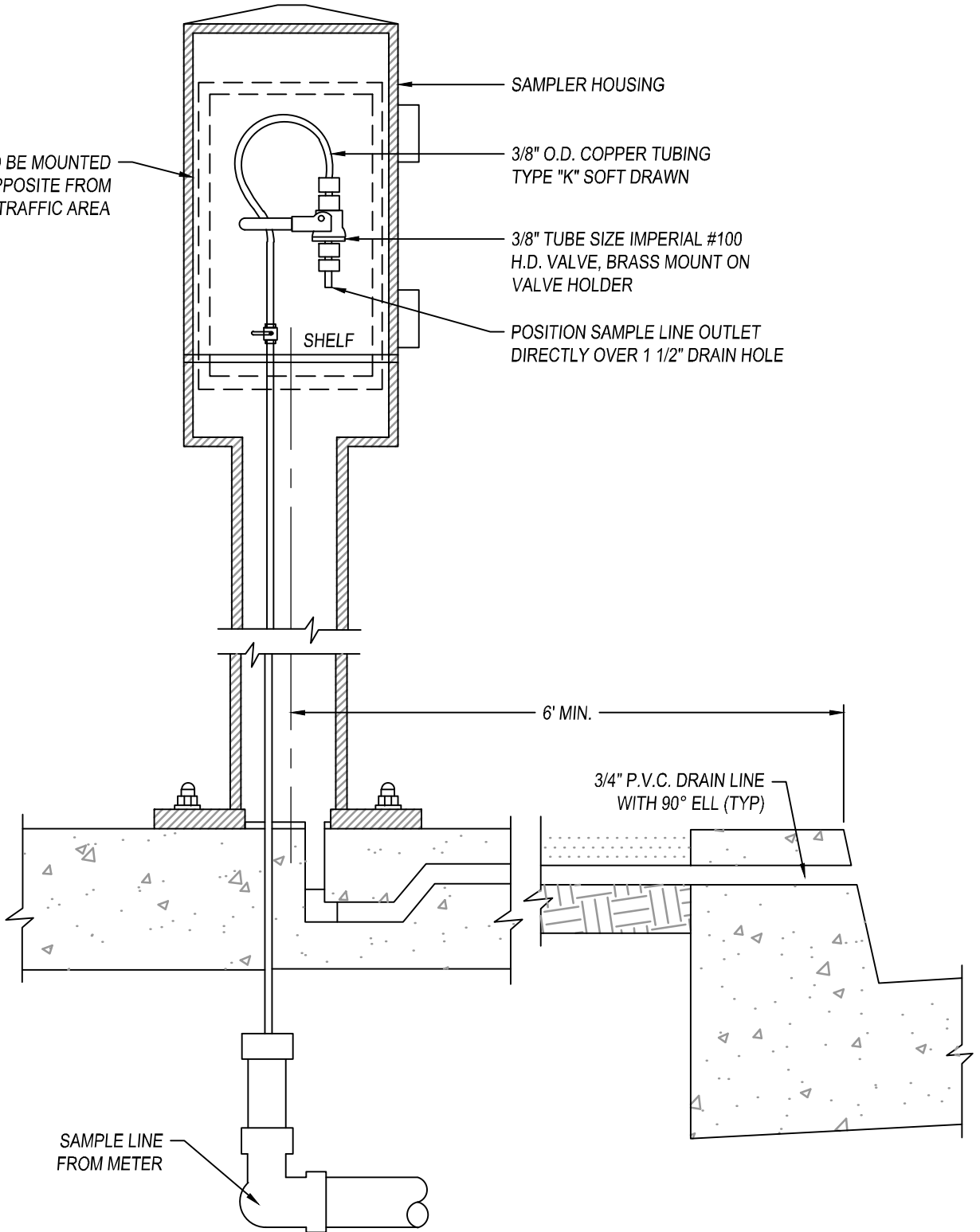

SAMPLER HOUSING

3/8" O.D. COPPER TUBING
TYPE "K" SOFT DRAWN

3/8" TUBE SIZE IMPERIAL #100
H.D. VALVE, BRASS MOUNT ON
VALVE HOLDER

POSITION SAMPLE LINE OUTLET
DIRECTLY OVER 1 1/2" DRAIN HOLE

SHELF

6" MIN.

3/4" P.V.C. DRAIN LINE
WITH 90° ELL (TYP)

SAMPLE LINE
FROM METER



CITY COUNCIL APPROVAL: 01/24/2023

APPROVED BY CITY ENGINEER

APPROVED BY PUBLIC WORKS DIRECTOR

WATER SAMPLE STATION
(SHEET 2 OF 2)

PUBLIC IMPROVEMENT STANDARDS

W-19

REVISIONS

NAME	BY	DATE

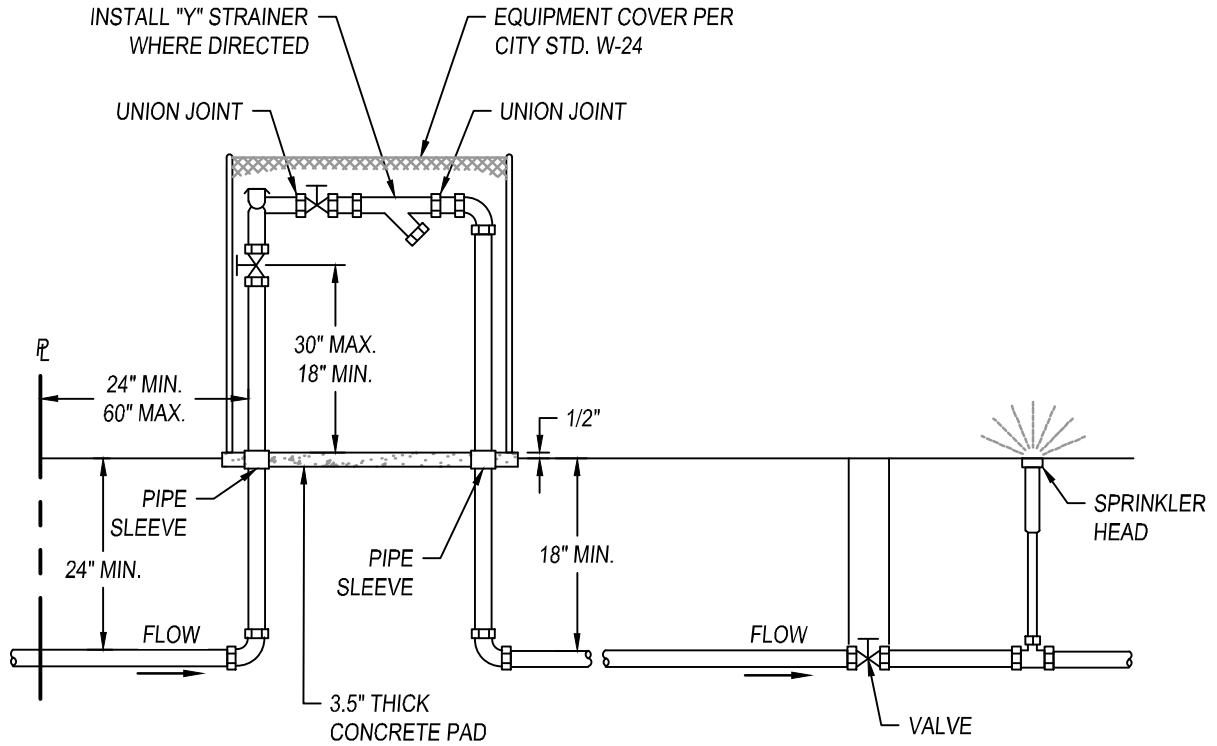

NOTES:

1. RESILIENT SEATED SHUT-OFF VALVES AND TEST COCKS ARE REQUIRED.
2. NO TAPS, TEES OR CONNECTIONS OF ANY KIND ARE PERMITTED BETWEEN THE WATER METER AND THE PRESSURE VACUUM BREAKER ASSEMBLY.
3. PROTECTION FROM FREEZE DAMAGE IS REQUIRED IN EXPOSED AREAS.
4. ASSEMBLY MUST BE ACCESSIBLE FOR TESTING AND MAINTENANCE PER CITY OF DINUBA MUNICIPAL CODE.
5. ASSEMBLY TO BE THE SAME SIZE AS THE WATER SUPPLY LINE PER UNIFORM PLUMBING CODE.
6. PRESSURE LOSS THROUGH PRESSURE VACUUM BREAKER ASSEMBLY MUST BE INCLUDED IN PRESSURE LOSS CALCULATIONS FOR SIZING OF THE WATER SYSTEM PER UNIFORM PLUMBING CODE.
7. DOWNSTREAM PIPING MAY HAVE VALVES IN SYSTEM.
8. INSTALL ONE UNION IN THE PIPING SYSTEM WITHIN 12 INCHES OF THE ASSEMBLY.
9. ASSEMBLY CAN NOT BE SUBJECT TO BACK PRESSURE FROM PUMPS, ELEVATION, OR OTHER SOURCES.
10. MAINTAIN A MINIMUM OF 12 INCHES, MAXIMUM OF 18 INCHES CLEARANCE AROUND ASSEMBLY.
11. ANY DEVIATION FROM THESE REQUIREMENTS SHALL BE APPROVED BY THE PUBLIC WORKS DEPARTMENT PRIOR TO INSTALLATION.



CITY COUNCIL APPROVAL: 01/24/2023
 APPROVED BY CITY ENGINEER
 APPROVED BY PUBLIC WORKS DIRECTOR

**PRESSURE VACUUM BREAKER
 BLACKFLOW PREVENTER INSTALLATION**
PUBLIC IMPROVEMENT STANDARDS

W-20		
REVISIONS		
NAME	BY	DATE

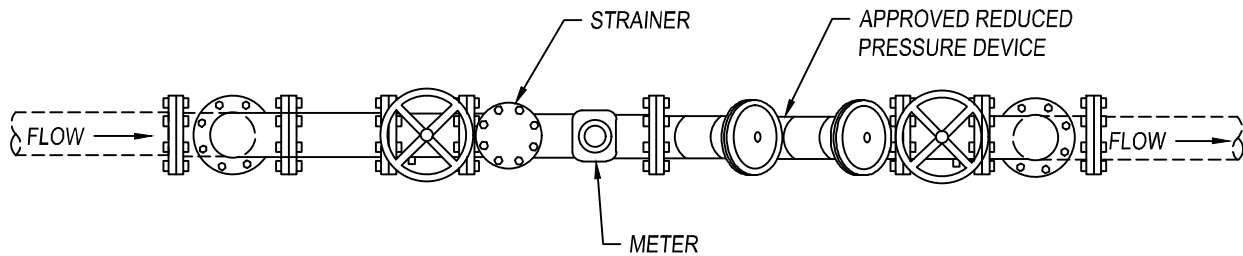

PLAN VIEW

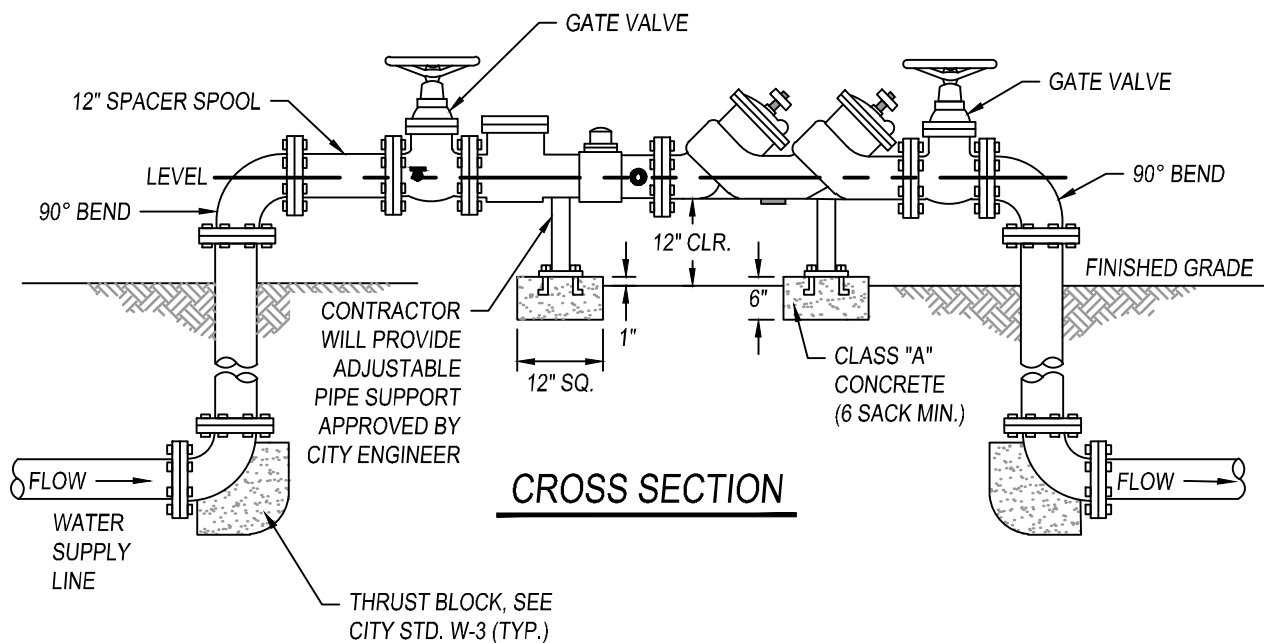

CROSS SECTION

NOTES:

1. INLET AND OUTLET VALVES TO BE INSTALLED AT EACH END OF ASSEMBLY.
2. ALL WATER METERS SHALL BE "NEPTUNE" REMOTE READ, OR APPROVED EQUAL.
3. ALL WATER METERS LARGER THAN 2" SHALL BE PROVIDED BY THE OWNER, DEVELOPER, OR CONTRACTOR.



CITY COUNCIL APPROVAL: 01/24/2023

APPROVED BY CITY ENGINEER

APPROVED BY PUBLIC WORKS DIRECTOR

**COMPOUND OR TURBINE METER SETTING
WITH REDUCED PRESSURE DEVICE
PUBLIC IMPROVEMENT STANDARDS**

W-21

REVISIONS

NAME	BY	DATE

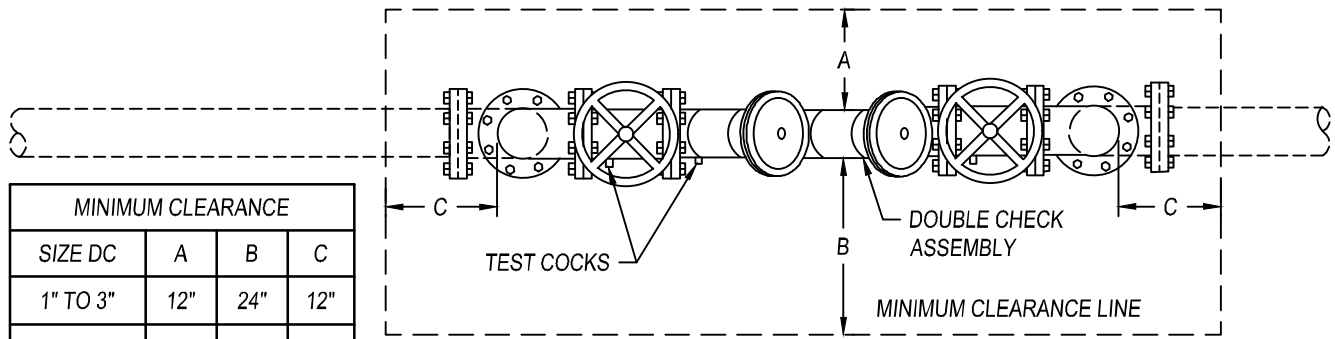
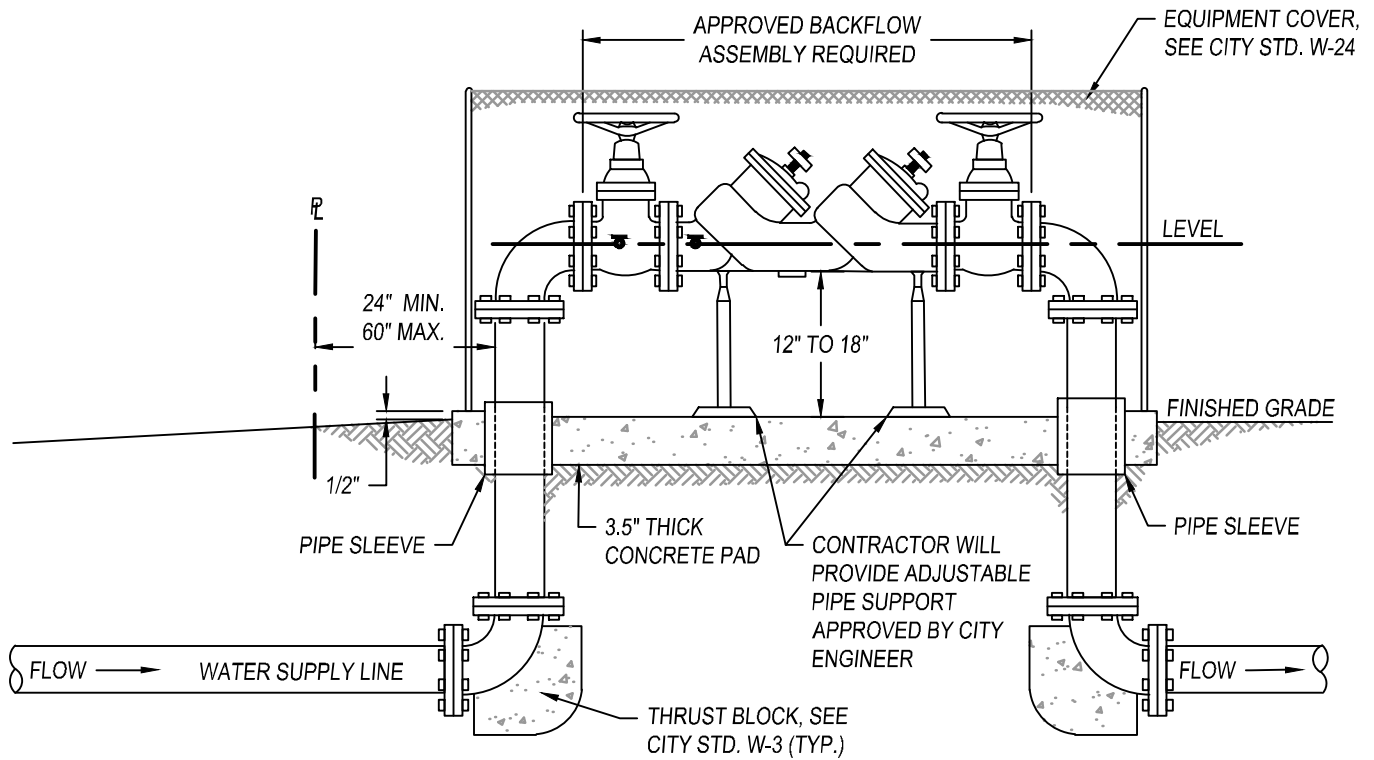

MINIMUM CLEARANCE			
SIZE DC	A	B	C
1" TO 3"	12"	24"	12"
4" & UP	24"	24"	12"

NOTES:

1. RESILIENT SEATED SHUT OFF VALVES AND TEST COCKS ARE REQUIRED.
2. NO TAPS, TEES, CONNECTIONS OF ANY KIND ARE PERMITTED BETWEEN THE WATER METER AND THE BACKFLOW ASSEMBLY.
3. PROTECTION FROM FREEZE DAMAGE MAY BE REQUIRED IN EXPOSED AREAS.
4. ASSEMBLY MUST BE ACCESSIBLE FOR TESTING AND MAINTENANCE PER CITY OF DINUBA PUBLIC WORKS DEPARTMENT.
5. ASSEMBLY TO BE THE SAME SIZE AS THE WATER SUPPLY LINE PER UNIFORM PLUMBING CODE.
6. PRESSURE LOSS THROUGH ASSEMBLY MUST BE INCLUDED IN PRESSURE LOSS CALCULATIONS FOR SIZING OF THE WATER SYSTEM PER UNIFORM BUILDING CODE.
7. MINIMUM CLEARANCES AROUND ASSEMBLY MUST BE MAINTAINED. REFER TO MINIMUM CLEARANCE CHART ON THIS PAGE.
8. DRAINAGE TO EXTERIOR OF THE BUILDING IS REQUIRED WHEN ASSEMBLY IS INSTALLED INSIDE.
9. ANY DEVIATION FROM THESE REQUIREMENTS SHALL BE APPROVED BY THE WATER SYSTEM MANAGER OR CROSS CONNECTION CONTROL SPECIALIST PRIOR TO INSTALLATION.
10. THE BACKFLOW PREVENTER DEVICES AND INSTALLATIONS SHALL BE APPROVED BY THE CITY OF DINUBA PUBLIC WORKS DEPARTMENT.
11. BACKFLOW ASSEMBLY SHALL BE INSPECTED AND TESTED BY THE PUBLIC WORKS DEPARTMENT OR PROVIDE A CERTIFICATE SHOWING THE ASSEMBLY WAS TESTED AND PASSED.



CITY COUNCIL APPROVAL: 01/24/2023
 APPROVED BY CITY ENGINEER
 APPROVED BY PUBLIC WORKS DIRECTOR

DOUBLE CHECK VALVE

PUBLIC IMPROVEMENT STANDARDS

W-22

REVISIONS		
NAME	BY	DATE

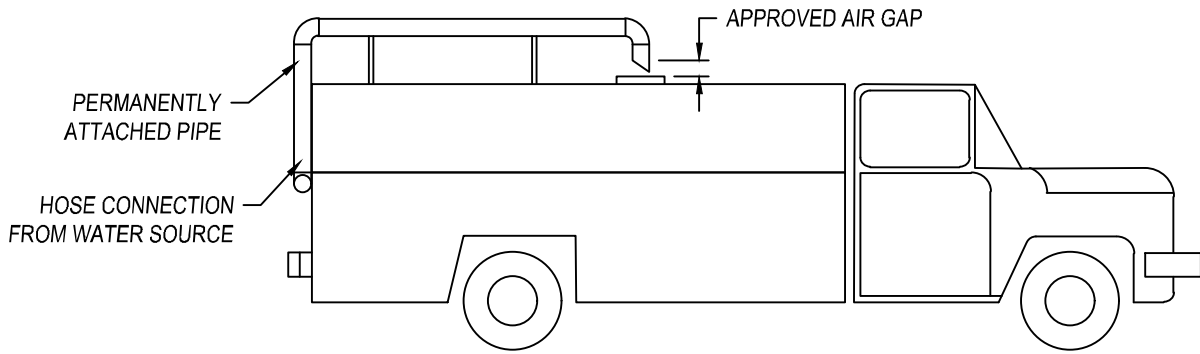

AIR-GAP PROTECTION

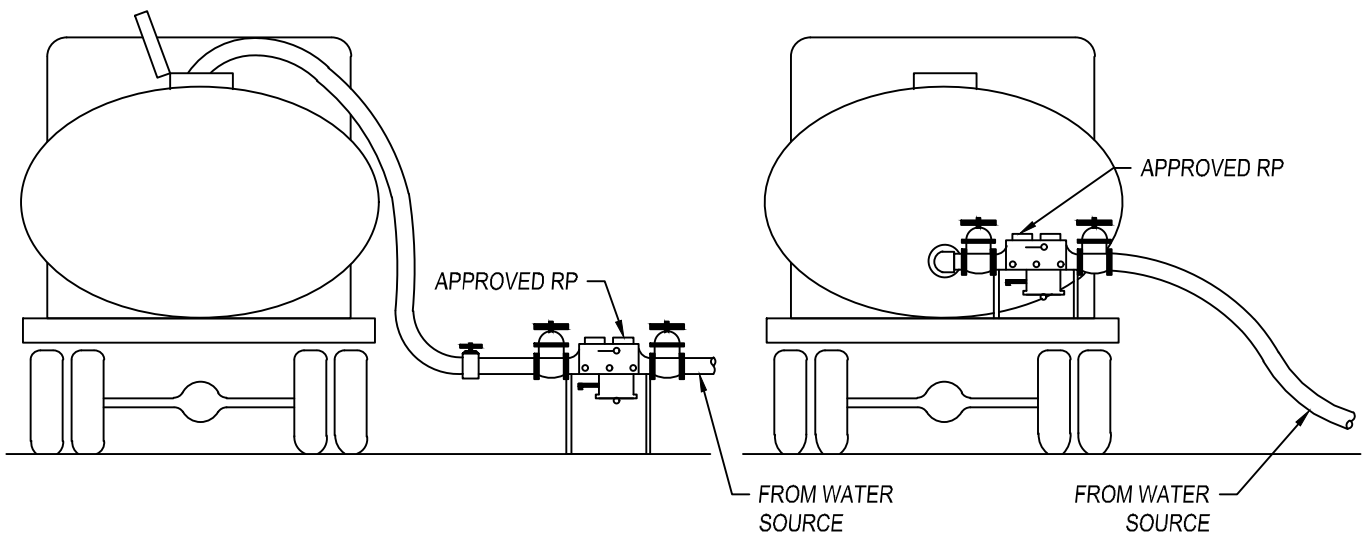

MECHANICAL ASSEMBLY PROTECTION

REQUIREMENTS:

1. AIR-GAP MUST BE AN APPROVED "AIR-GAP" SYSTEM.
2. MECHANICAL BACKFLOW PREVENTER MUST BE AN APPROVED REDUCED PRESSURE PRINCIPAL ASSEMBLY.
3. BACKFLOW ASSEMBLY MUST BE TESTED BY A CERTIFIED BACKFLOW PREVENTION DEVICE TESTER, WHO IS REGISTERED WITH CITY. THE TESTS SHALL BE PERFORMED ONCE A YEAR. THE TEST RESULTS MUST BE PROVIDED TO THE CITY.
4. TYPICAL EQUIPMENT: WATER TRUCKS, PEST CONTROL TRUCKS, HYDROSEEDING EQUIPMENT, PORTABLE WASHING, AND STEAM CLEANING EQUIPMENT.



CITY COUNCIL APPROVAL: 01/24/2023

[Signature]
APPROVED BY CITY ENGINEER

[Signature]
APPROVED BY PUBLIC WORKS DIRECTOR

APPROVED PORTABLE WATER
TRANSPORT BACKFLOW PROTECTION
PUBLIC IMPROVEMENT STANDARDS

W-23

REVISIONS

NAME	BY	DATE

LIFT-OFF ENCLOSURES

TYPE	LENGTH (L)	HEIGHT (H)	WIDTH (W)
GS-5	12"	18"	10"
GS-1	22"	24"	10"
GS-2	30"	24"	10"
GS-3.3	30"	30"	16"

- PLASTICOTE POWDER COAT FINISH
- ACCEPTS PADLOCK
- FOREST GREEN IN COLOR

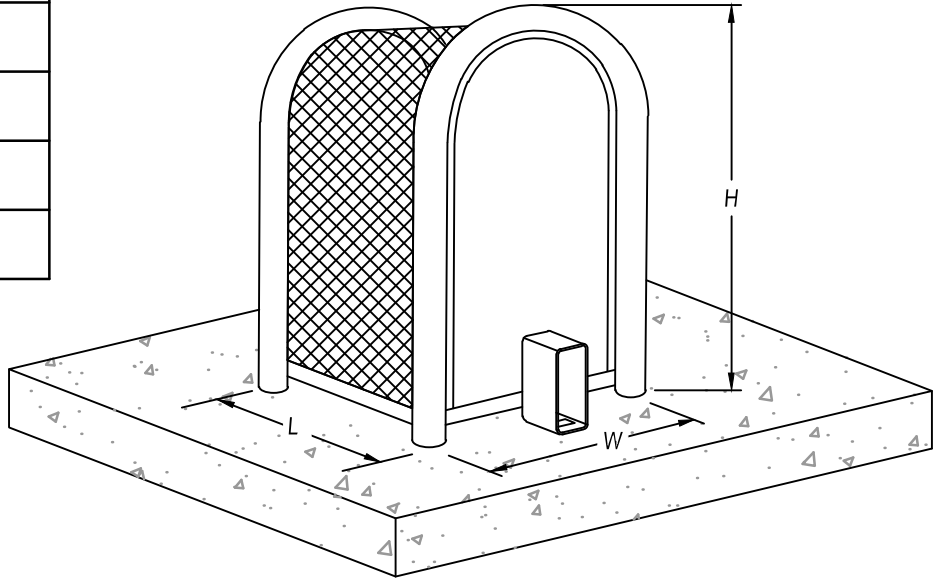

HINGED BODY ENCLOSURES

TYPE	LENGTH (L)	HEIGHT (H)	WIDTH (W)
GS-3	40"	24"	10"
GS-4	46"	30"	16"

- PLASTICOTE POWDER COAT FINISH
- ACCEPTS PADLOCK
- HINGED FOR EASY ACCESS
- FOREST GREEN IN COLOR

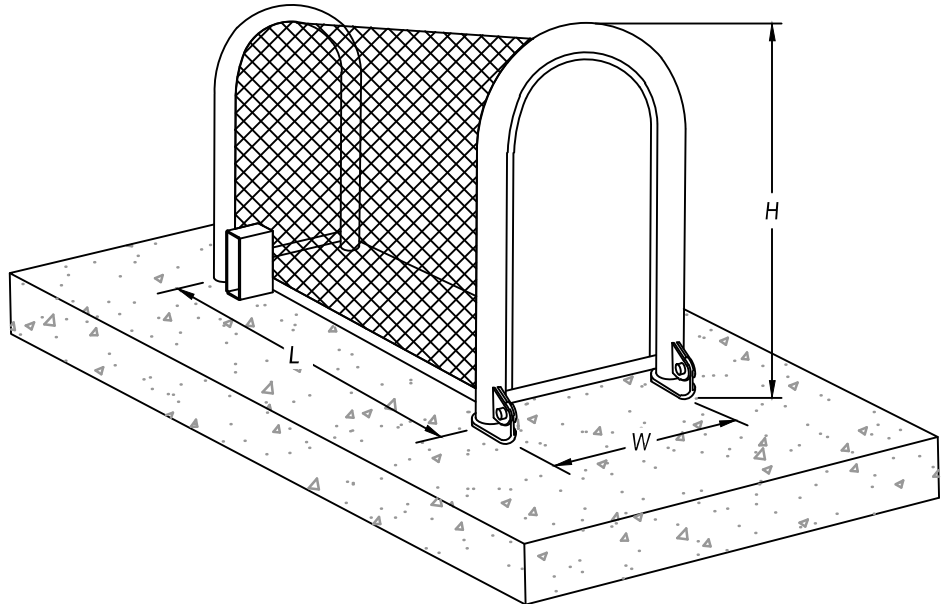

CITY COUNCIL APPROVAL: 01/24/2023

[Signature]
APPROVED BY CITY ENGINEER

[Signature]
APPROVED BY PUBLIC WORKS DIRECTOR

EQUIPMENT COVERS

PUBLIC IMPROVEMENT STANDARDS

W-24

REVISIONS

NAME	BY	DATE

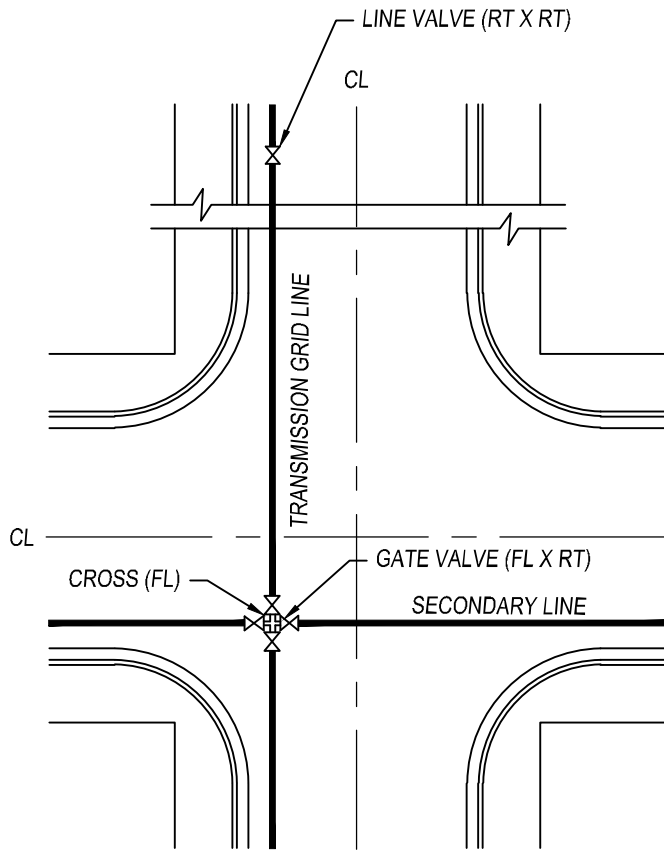

CROSS CONNECTION

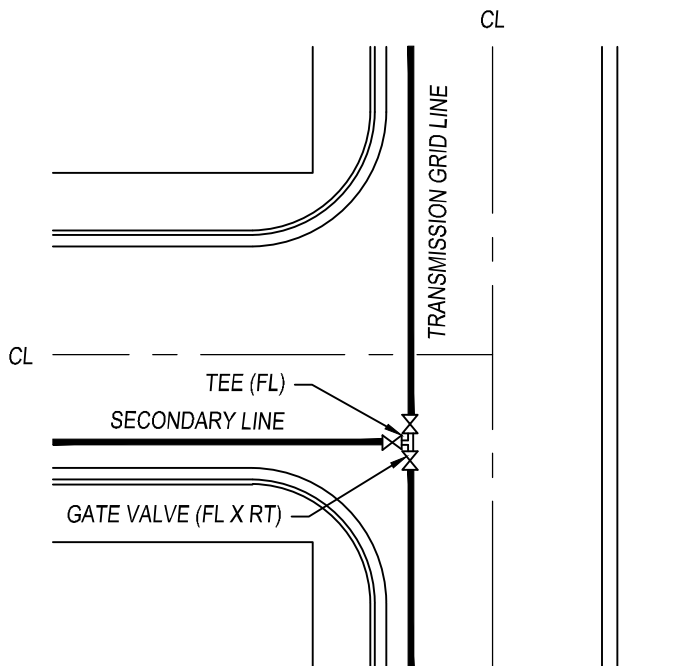

TEE CONNECTION

NOTES:

1. MAXIMUM DISTANCE BETWEEN VALVES IS 500'.



CITY COUNCIL APPROVAL: 01/24/2023

APPROVED BY CITY ENGINEER

APPROVED BY PUBLIC WORKS DIRECTOR

WATER MAIN INTERSECTION CONNECTIONS

PUBLIC IMPROVEMENT STANDARDS

W-25

REVISIONS

NAME	BY	DATE

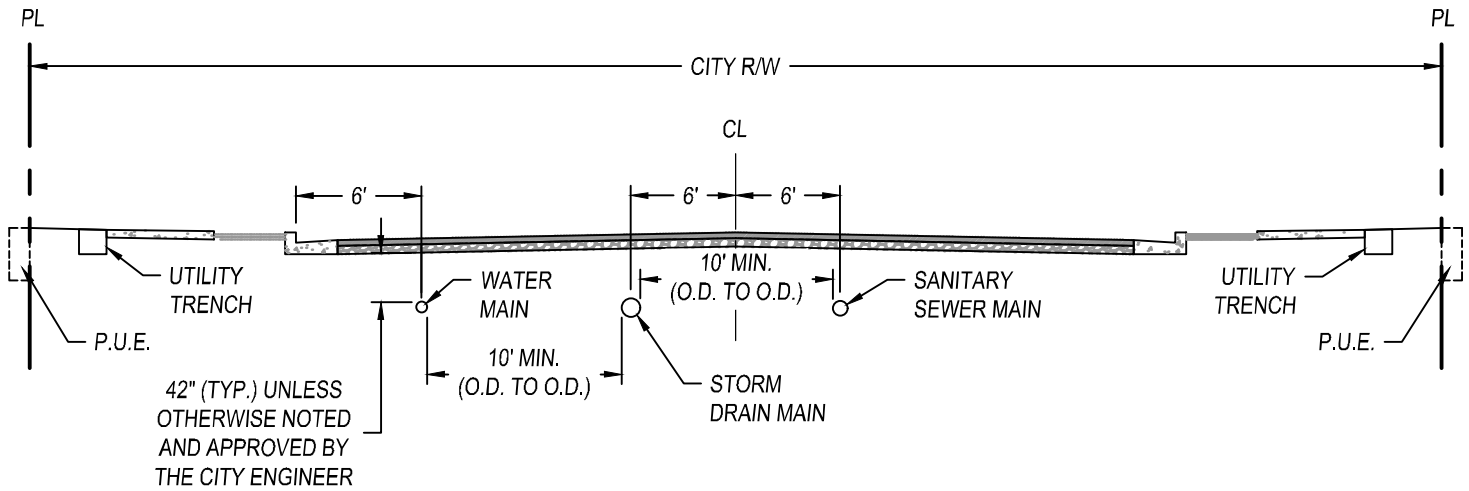

MINIMUM PIPE DIAMETER FOR:

- WATER MAIN: 8"
- SANITARY SEWER MAIN: 8"
- STORM DRAIN MAIN: 18"

NOTES:

1. WATER MAINS AND STORM DRAIN MAINS SHALL BE PLACED NORTH OR WEST OF THE STREET CENTERLINE.
2. SANITARY SEWER MAINS SHALL BE PLACED TO THE SOUTH OR EAST OF THE STREET CENTERLINE.
3. FOR LOCATION OF WATER SERVICES AND SEWER LATERALS, SEE CITY STD. SS-1.
4. THERE SHALL BE A 10' MINIMUM OUTSIDE OF PIPE TO OUTSIDE OF PIPE DISTANCE BETWEEN WATER MAINS, SANITARY SEWER MAINS AND STORM DRAIN MAINS.
5. BACKFILL IN PARKWAY OR STREET INSTALLATIONS SHALL BE AS REQUIRED BY CITY STD. W-12.
6. LOCATION OF UTILITY TRENCHES SHALL BE WITHIN THE P.U.E. EXCEPT FOR CROSSINGS.
7. AT NO TIME WILL SANITARY SEWER LINES BE ALLOWED IN A TRENCH OCCUPIED BY PRIMARY OR SECONDARY ELECTRICAL POWER.
8. EACH UTILITY COMPANY MAY HAVE ONE OR MORE CONDUITS OR CONDUCTORS IN A JOINT UTILITY TRENCH.
9. DEPTHS TO VARY ACCORDING TO CONDUIT SIZES AND LATERAL INTERFERENCE AND UTILITY COMPANY SPECIFICATIONS.
10. ALL CONDUCTORS OR CONDUITS SHALL HAVE 3" MINIMUM CLEARANCE FROM TRENCH SIDEWALL.



CITY COUNCIL APPROVAL: 01/24/2023

[Signature]
APPROVED BY CITY ENGINEER

[Signature]
APPROVED BY PUBLIC WORKS DIRECTOR

LOCATIONS OF UTILITY MAINS

PUBLIC IMPROVEMENT STANDARDS

W-26

REVISIONS

NAME	BY	DATE

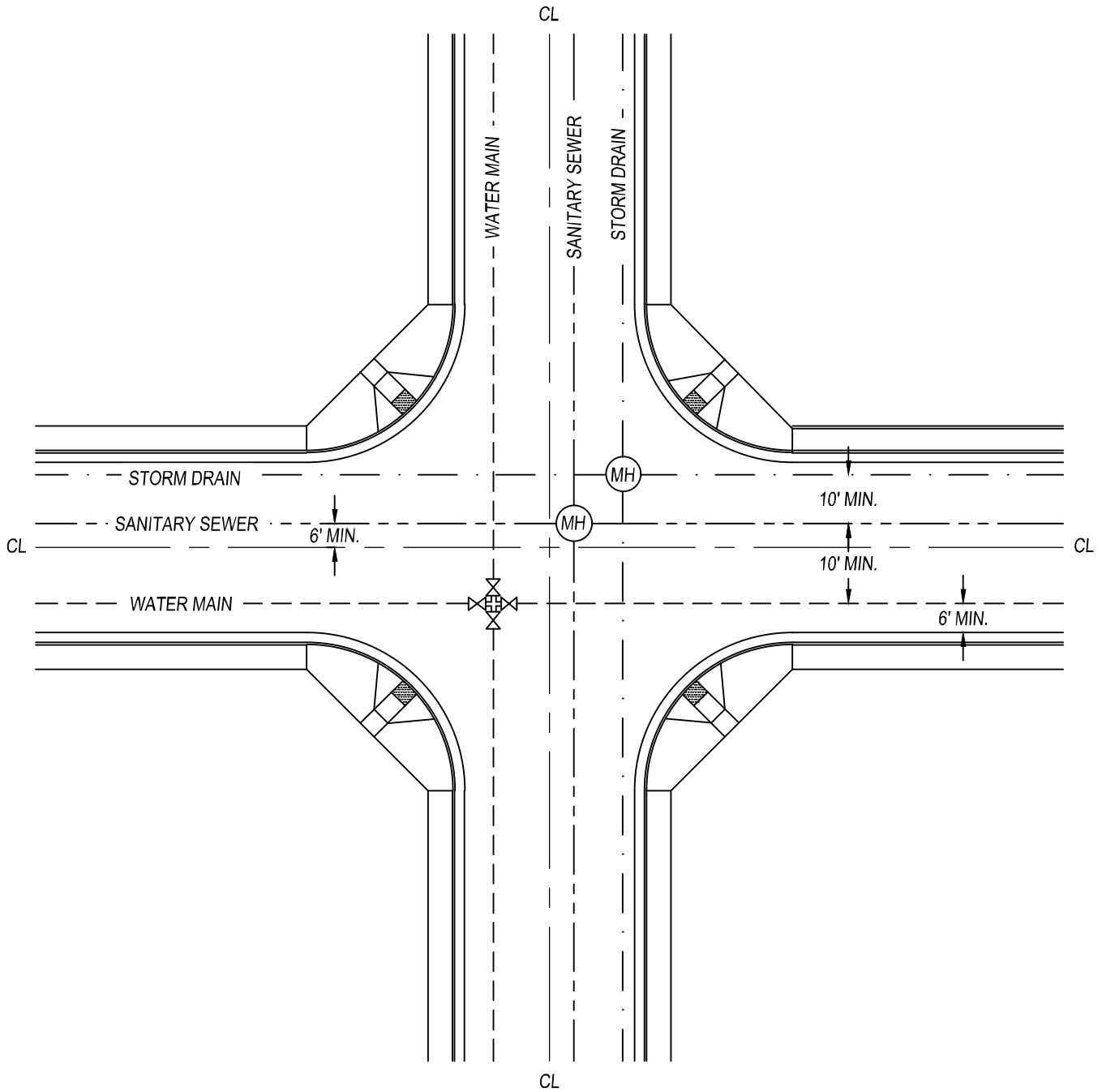

NOTES:

1. THIS "STANDARD" IS A GUIDE ONLY AND DEVIATIONS WILL BE ACCEPTABLE WHERE CONDITIONS DICTATE.
2. DIMENSIONS SHOWN ARE DESIRABLE BUT DO NOT GOVERN.
3. THE INTENTION IS TO SHOW THE RELATIVE POSITION OF ALL UTILITIES.
4. ANY CHANGES OR DEVIATION MUST BE APPROVED BY THE CITY ENGINEER.



CITY COUNCIL APPROVAL: 01/24/2023

[Signature]
APPROVED BY CITY ENGINEER

[Signature]
APPROVED BY PUBLIC WORKS DIRECTOR

LOCATIONS FOR UNDERGROUND CONDUITS
& PIPES IN RESIDENTIAL AREA CITY STREETS

PUBLIC IMPROVEMENT STANDARDS

W-27

REVISIONS

NAME	BY	DATE