

INITIAL STUDY/MITIGATED NEGATIVE DECLARATION

Empire Estates Residential Project

Prepared for:



City of Dinuba
405 E. El Monte Way
Dinuba, CA 93618
(559) 591-5900
Contact: Karl Schoettler

Prepared by:



Crawford & Bowen Planning, Inc.
113 N. Church Street, Suite 310
Visalia, CA 93291
(559) 840-4414
Contact: Emily Bowen, LEED AP

March 2024

TABLE OF CONTENTS

PROJECT INFORMATION	4
Project title	4
Lead agency name and address	4
Contact person and phone number	4
Project location.....	4
Project sponsor’s name/address	5
General plan designation	5
Zoning.....	5
Project Description	5
Surrounding Land Uses/Existing Conditions	6
Other Public Agencies Involved	6
Tribal Consultation	7
ENVIRONMENTAL FACTORS POTENTIALLY AFFECTED	11
DETERMINATION	Error! Bookmark not defined.
ENVIRONMENTAL CHECKLIST	13
I. AESTHETICS.....	13
II. AGRICULTURE AND FOREST RESOURCES.....	17
III. AIR QUALITY	19
IV. BIOLOGICAL RESOURCES.....	35
V. CULTURAL RESOURCES	46
VI. ENERGY	49
VII. GEOLOGY AND SOILS.....	55

VIII. GREENHOUSE GAS EMISSIONS..... 60

IX. HAZARDS AND HAZARDOUS MATERIALS 68

X. HYDROLOGY AND WATER QUALITY 73

XI. LAND USE AND PLANNING 79

XII. MINERAL RESOURCES..... 81

XIII. NOISE..... 82

XIV. POPULATION AND HOUSING 86

XV. PUBLIC SERVICES..... 88

XVI. RECREATION 91

XVII. TRANSPORTATION/TRAFFIC..... 93

XVIII. TRIBAL CULTURAL RESOURCES..... 101

XX. WILDFIRE..... 107

XXI. MANDATORY FINDINGS OF SIGNIFICANCE 109

LIST OF PREPARERS 111

PROJECT INFORMATION

This document is the Initial Study for the potential environmental effects of the Dinuba Empire Estates Residential Project (Project) proposed in the City of Dinuba (City). To accommodate this Project, the City will need to approve an Annexation, Zone Change, and Tentative Subdivision Map. The City of Dinuba will act as the Lead Agency for this project pursuant to the California Environmental Quality Act (CEQA) and the CEQA Guidelines. Copies of all materials referenced in this report are available for review in the project file during regular business hours at the Dinuba Public Works Department at 1088 E. Kamm Ave, Dinuba, CA 93618.

Project title

Empire Estates Residential Project

Lead agency name and address

City of Dinuba
1088 E Kamm Ave
Dinuba, CA 93618

Contact person and phone number

Karl Schoettler
City of Dinuba
(559) 591-5924
Email: karl@weplancities.com

Project location

The City of Dinuba lies in the Central San Joaquin Valley region, in the northwestern portion of Tulare County (see Figure 1). The City is approximately eight miles northeast of State Route (SR) 99 and 5.5 miles west of SR 63. The proposed Project site is located west of Dinuba, outside the City limits but within the Urban Development Boundary, northwest of Road 72 and West Sierra Way/Avenue 412 (see Figure 2). The proposed development is located on an approximately 18.6 acre site on Assessor's Parcel Number 012-290-011 (see Figure 3).

Project sponsor's name/address

Jose Lemus
6702 N. Cedar Ave, Suite 201
Fresno, CA 93710

General plan designation

Existing: Residential – Medium Low

Proposed: Residential – Medium

Zoning

Existing: R-1-7.5 (Medium Low Density Residential)

Proposed: R-1-6 (Medium Density Residential)

Project Description

The Project Applicant intends to develop 75 single-family residential units on an approximately 18.6-acre site. The site is currently outside the western City limits of Dinuba, but within the City's Sphere of Influence. The development will also include access roads, lighting and other associated improvements. Entitlements needed to accommodate the proposed Project include Annexation, Zone Change, and a Tentative Subdivision Map. The proposed Project site is currently vacant, with an existing residential dwelling in the southwestern portion, which will be removed as part of the Project (see Figure 3 for Site Plan).

Project Components

- Development of 75 single-family residential units
- Removal of residence in the southwest portion of the site
- Existing irrigation canal to be piped and undergrounded
- Construction of internal roads, landscaping, and a block wall per City Standards
- Construction of curb, gutter and sidewalks, per City Standards
- Connection to City utilities, including stormwater, sewer and water
- Approval of Zone change from Medium-Low Density Residential to Medium Density Residential

- Approval of Tentative Subdivision Map

Site Circulation

Access to and from the Project site will be from two (2) access points at buildout. The first access point will be located along the east side of Road 70 approximately 500 feet north of Avenue 412 and is proposed to be full access. The second access point will be located along the west side of Road 72 approximately 300 feet north of Avenue 412 and is also proposed to be full access.

Surrounding Land Uses/Existing Conditions

The Project site currently supports a recently disced agricultural field and two residential structures with outbuildings near its western boundary. The Project site is otherwise sparsely vegetated, mainly with ruderal, nonnative grasses and forbs. An earthen agricultural drainage ditch (Horsman Ditch) spanned the eastern boundary of the Project site.

Lands surrounding the proposed Project are described as follows:

- North: Agricultural row crops, Rural residence
- South: West Sierra Way/Avenue 412, Agricultural row crops, Rural residence
- East: Road 72, Warehouse, Park, Water tower
- West: Road 70, Rural residence, Agricultural row crops

Other Public Agencies Involved

- Approval of a Zone Change by the City of Dinuba
- Approval of a Tentative Subdivision Map by the City of Dinuba
- Approval of Annexation by Tulare County LAFCo
- Approval of Building Permits by the City of Dinuba
- Adoption of a Mitigated Negative Declaration by the City of Dinuba
- State of California Native American Heritage Commission
- San Joaquin Valley Air Pollution Control District
- Central Valley Regional Water Quality Control Board
- Compliance with other federal, state and local requirements

Tribal Consultation

The City of Dinuba has not received any Project-specific requests from any Tribes in the geographic area with which it is traditionally and culturally affiliated with or otherwise to be notified about projects in the City of Dinuba.

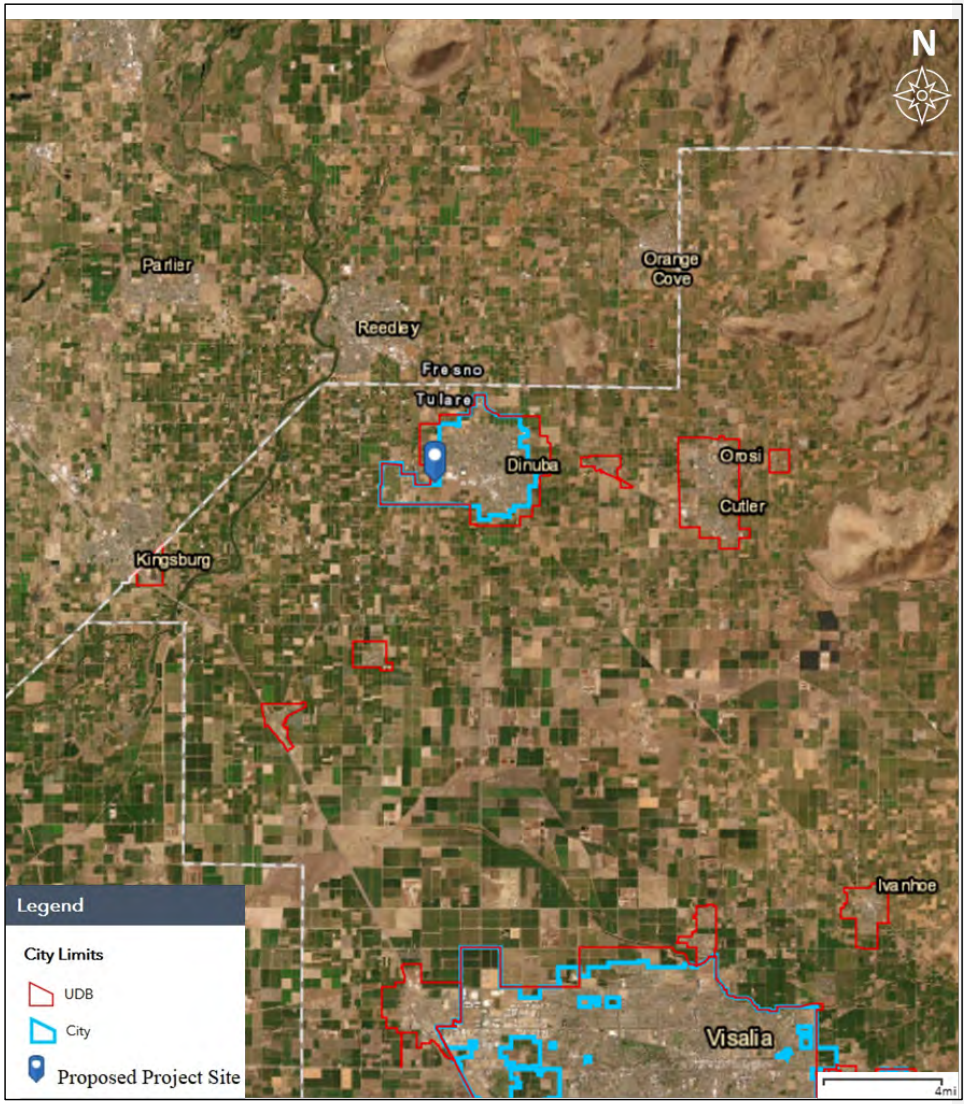

Figure 1 – Location

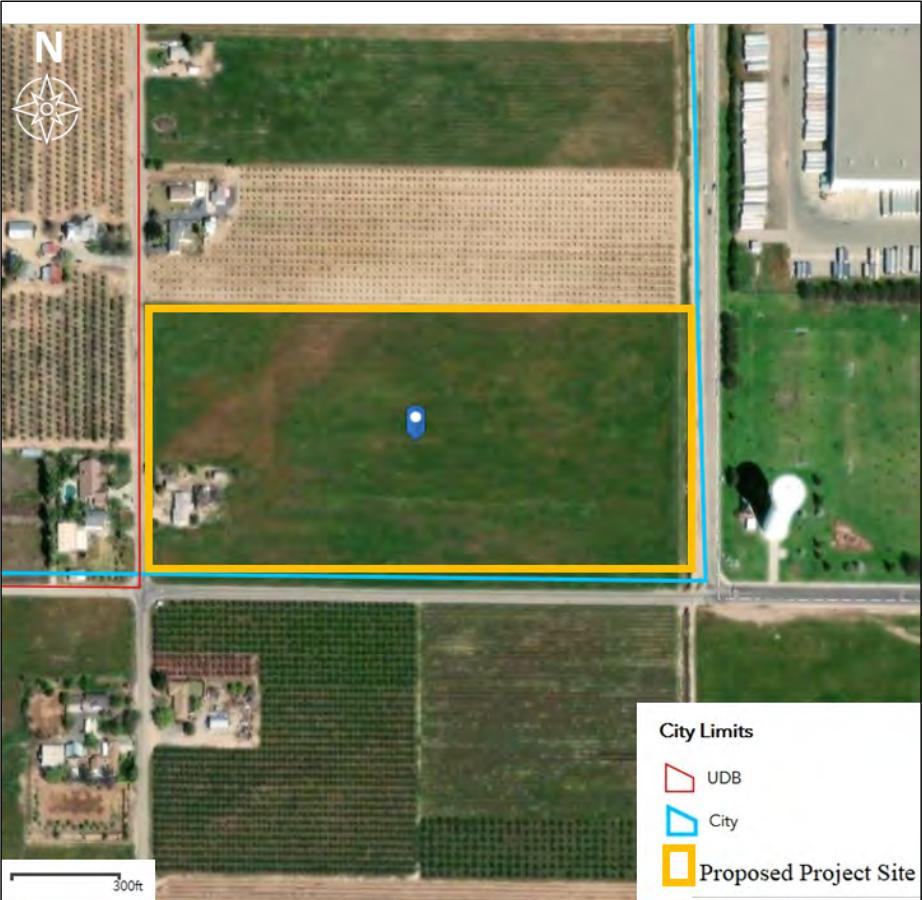
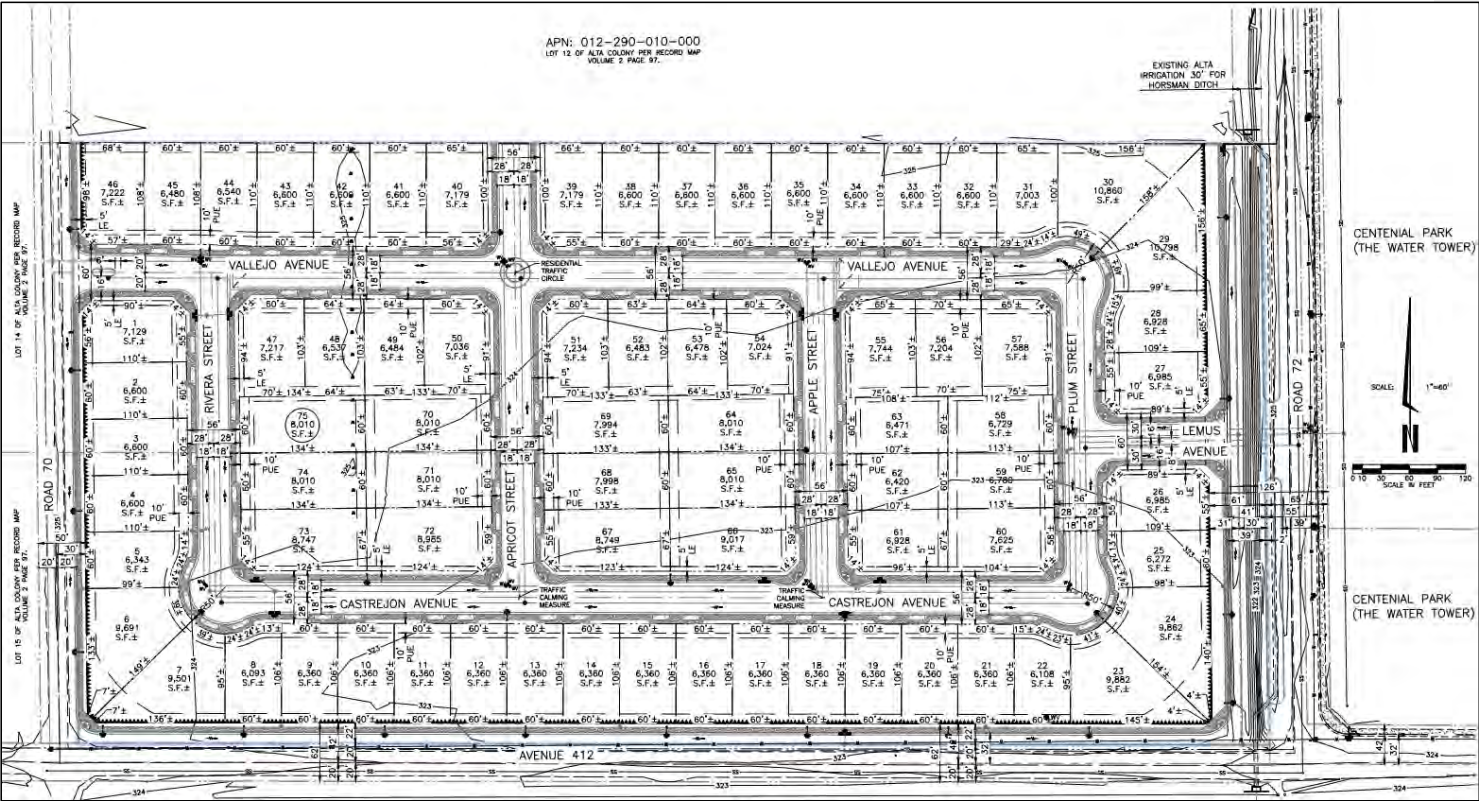

Figure 2 – Site Aerial

Figure 3 – Site Plan



ENVIRONMENTAL FACTORS POTENTIALLY AFFECTED

The environmental factors checked below would be potentially affected by this project, involving at least one impact that is a “Potentially Significant Impact” as indicated by the checklist on the following pages.

- | | | |
|--|---|---|
| <input type="checkbox"/> Aesthetics | <input type="checkbox"/> Agriculture Resources and Forest Resources | <input type="checkbox"/> Air Quality |
| <input type="checkbox"/> Biological Resources | <input type="checkbox"/> Cultural Resources | <input type="checkbox"/> Energy |
| <input type="checkbox"/> Geology / Soils | <input type="checkbox"/> Greenhouse Gas Emissions | <input type="checkbox"/> Hazards & Hazardous Materials |
| <input type="checkbox"/> Hydrology / Water Quality | <input type="checkbox"/> Land Use / Planning | <input type="checkbox"/> Mineral Resources |
| <input type="checkbox"/> Noise | <input type="checkbox"/> Population / Housing | <input type="checkbox"/> Public Services |
| <input type="checkbox"/> Recreation | <input type="checkbox"/> Transportation | <input type="checkbox"/> Tribal Cultural Resources |
| <input type="checkbox"/> Utilities / Service Systems | <input type="checkbox"/> Wildfire | <input type="checkbox"/> Mandatory Findings of Significance |

DETERMINATION

On the basis of this initial evaluation:

I find that the proposed project COULD NOT have a significant effect on the environment, and a NEGATIVE DECLARATION will be prepared.

I find that although the proposed project could have a significant effect on the environment, there will not be a significant effect in this case because revisions in the project have been made by or agreed to by the project proponent. A MITIGATED NEGATIVE DECLARATION will be prepared.

I find that the proposed project MAY have a significant effect on the environment, and an ENVIRONMENTAL IMPACT REPORT is required.

I find that the proposed project MAY have a “potentially significant impact” or “potentially significant unless mitigated” impact on the environment, but at least one effect 1) has been adequately analyzed in an earlier document pursuant to applicable legal standards, and 2) has been addressed by mitigation measures based on the earlier analysis as described on attached sheets. An ENVIRONMENTAL IMPACT REPORT is required, but it must analyze only the effects that remain to be addressed.

I find that although the proposed project could have a significant effect on the environment, because all potentially significant effects (a) have been analyzed adequately in an earlier EIR or NEGATIVE DECLARATION pursuant to applicable standards, and (b) have been avoided or mitigated pursuant to that earlier EIR or NEGATIVE DECLARATION, including revisions or mitigation measures that are imposed upon the proposed project, nothing further is required.

Karl Schoettler

3/15/23

Karl Schoettler
Planning Consultant
City of Dinuba

Date

ENVIRONMENTAL CHECKLIST

I. AESTHETICS

Would the project:

	Potentially Significant Impact	Less than Significant With Mitigation Incorporation	Less than Significant Impact	No Impact
a. Have a substantial adverse effect on a scenic vista?	<input type="checkbox"/>	<input type="checkbox"/>	<input checked="" type="checkbox"/>	<input type="checkbox"/>
b. Substantially damage scenic resources, including, but not limited to, trees, rock outcroppings, and historic buildings within a state scenic highway?	<input type="checkbox"/>	<input type="checkbox"/>	<input checked="" type="checkbox"/>	<input type="checkbox"/>
c. In non-urbanized areas, substantially degrade the existing visual character or quality of public views of the site and its surroundings? (Public views are those that are experienced from publicly accessible vantage point). If the project is in an urbanized area, would the project conflict with applicable zoning and regulations governing scenic quality?	<input type="checkbox"/>	<input type="checkbox"/>	<input checked="" type="checkbox"/>	<input type="checkbox"/>
d. Create a new source of substantial light or glare which would adversely affect day or nighttime views in the area?	<input type="checkbox"/>	<input type="checkbox"/>	<input checked="" type="checkbox"/>	<input type="checkbox"/>

ENVIRONMENTAL SETTING

The Project site currently supports a recently disced agricultural field and two residential structures with outbuildings near its western boundary. The Project site is otherwise sparsely vegetated, mainly with ruderal, nonnative grasses and forbs. An earthen agricultural drainage ditch (Horsman Ditch) spanned the eastern boundary of the Project site. Lands surrounding the proposed Project are agricultural row crops and rural residence to the north; West Sierra Way/Avenue 412, agricultural row crops and rural residence to the south; Road 72, industrial warehouse, vacant land, water tower to the east; and Road 70, rural residence, and agricultural row crops to the west.

RESPONSES

- a) Have a substantial adverse effect on a scenic vista?
- b) Substantially damage scenic resources, including, but not limited to, trees, rock outcroppings, and historic buildings within a state scenic highway?

Less Than Significant Impact. The Project Applicant intends to develop 75 single-family residential units on an approximately 18.6-acre site. The site is currently outside the western City limits of Dinuba, but within the Sphere of Influence.

A scenic vista is defined as a viewpoint that provides expansive views of highly valued landscape for the benefit of the general public. The site consists of recently disked inactive agricultural land and a rural residence. The City of Dinuba does not identify any scenic vistas within the Project area. Tulare County identifies El Monte Way/Avenue 416 as part of a system of County scenic routes according to the Tulare County General Plan.¹ However, the proposed Project is located approximately 0.35 miles south of the road, and separated by intervening land uses. Therefore, views from this roadway to scenic resources would be unaffected by the development of the Project. There are no officially designated or eligible State Scenic Highways near the Project area. The Project has a *less than significant impact* on scenic vistas or designated scenic resources or highways.

Mitigation Measures: None are required.

- c) In non-urbanized areas, substantially degrade the existing visual character or quality of public views of the site and its surroundings? (Public views are those that are experienced from publicly accessible vantage point). If the project is in an urbanized area, would the project conflict with applicable zoning and regulations governing scenic quality?

Less than Significant Impact. The proposed Project would alter the existing visual character of public views of the site from vacant land to fully developed single-family residences. Upon approval of the Zone Change, and Tentative Subdivision Map, the Project design is subject to the City's Design Guidelines adopted for the City's General Plan which apply to site layout, building design, landscaping, interior street design, lighting, parking and signage. Per the City's Design Guidelines, detailed architectural plans, color palettes and building materials as well as landscaping plans will be

¹ Fig 7.1, Designated Candidate Scenic State Highways and County Scenic Routes, Tulare County General Plan 2012.

submitted by the Project developer to the City of Dinuba. The plans shall be required prior to issuance of any building permits. The review shall be substantially based on the building plans and elevations illustrated within this document.

The improvements such as those proposed by the Project are typical of City urban areas and are generally expected from residents of the City. These improvements would not substantially degrade the visual character of the area and would not diminish the visual quality of the area, as they would be consistent with the existing urban visual setting. The proposed Project itself is not visually imposing against the scale of the existing adjacent residential buildings and nature of the surrounding area.

Therefore, the Project would have *less than significant impacts* on the visual character of the area.

Mitigation Measures: None are required.

d) Create a new source of substantial light or glare which would adversely affect day or nighttime views in the area?

Less Than Significant Impact. Nighttime lighting is necessary to provide and maintain safe, secure, and attractive environments; however, these lights have the potential to produce spillover light and glare and waste energy, and if designed incorrectly, could be considered unattractive. Light that falls beyond the intended area is referred to as “light trespass”. Types of light trespass include spillover light and glare. Minimizing all these forms of obtrusive light is an important environmental consideration. A less obtrusive and well-designed energy efficient fixture would face downward, emit the correct intensity of light for the use, and incorporate energy timers.

Spillover light is light emitted by a lighting installation that falls outside the boundaries of the property on which the installation is sited. Spillover light can adversely affect light-sensitive uses, such as residential neighborhoods at nighttime. Because light dissipates as it travels from the source, the intensity of a light fixture is often increased at the source to compensate for the dissipated light. This can further increase the amount of light that illuminates adjacent uses. Spillover light can be minimized by using only the level of light necessary, and by using cutoff type fixtures or shielded light fixtures, or a combination of fixture types.

Glare results when a light source directly in the field of vision is brighter than the eye can comfortably accept. Squinting or turning away from a light source is an indication of glare. The presence of a bright light in an otherwise dark setting may be distracting or annoying, referred to as discomfort glare, or it may diminish the ability to see other objects in the darkened environment, referred to as disability glare. Glare can be reduced by design features that block direct line of sight to the light source and that

direct light downward, with little or no light emitted at high (near horizontal) angles, since this light would travel long distances. Cutoff-type light fixtures minimize glare because they emit relatively low-intensity light at these angles.

Current sources of light in the Project area are from adjacent residential and agricultural uses, including streetlights from the rural residences to the north, west and south, and industrial warehouse to the northeast. The Project would necessitate street lighting and such lighting that would be subject to City standards. Accordingly, potential impacts would be considered *less than significant*.

Mitigation Measures: None are required.

II. AGRICULTURE AND FOREST RESOURCES

Would the project:

	Potentially Significant Impact	Less than Significant With Mitigation Incorporation	Less than Significant Impact	No Impact
a. Convert Prime Farmland, Unique Farmland, or Farmland of Statewide Importance (Farmland), as shown on the maps prepared pursuant to the Farmland Mapping and Monitoring Program of the California Resources Agency, to non-agricultural use?	<input type="checkbox"/>	<input type="checkbox"/>	<input type="checkbox"/>	<input checked="" type="checkbox"/>
b. Conflict with existing zoning for agricultural use, or a Williamson Act contract?	<input type="checkbox"/>	<input type="checkbox"/>	<input type="checkbox"/>	<input checked="" type="checkbox"/>
c. Conflict with existing zoning for, or cause rezoning of, forest land (as defined in Public Resources Code section 12220(g)), timberland (as defined by Public Resources Code section 4526), or timberland zoned Timberland Production (as defined by Government Code section 51104(g))?	<input type="checkbox"/>	<input type="checkbox"/>	<input type="checkbox"/>	<input checked="" type="checkbox"/>
d. Result in the loss of forest land or conversion of forest land to non-forest use?	<input type="checkbox"/>	<input type="checkbox"/>	<input type="checkbox"/>	<input checked="" type="checkbox"/>
e. Involve other changes in the existing environment which, due to their location or nature, could result in conversion of Farmland, to non-agricultural use or conversion of forest land to non-forest use?	<input type="checkbox"/>	<input type="checkbox"/>	<input type="checkbox"/>	<input checked="" type="checkbox"/>

ENVIRONMENTAL SETTING

The proposed Project site is located in western Dinuba, outside the City limits but within the City's adopted Sphere of Influence, in Tulare County within the San Joaquin Valley, California.

RESPONSES

- a) Convert Prime Farmland, Unique Farmland, or Farmland of Statewide Importance (Farmland), as shown on the maps prepared pursuant to the Farmland Mapping and Monitoring Program of the California Resources Agency, to non-agricultural use?
- b) Conflict with existing zoning for agricultural use, or a Williamson Act contract?
- c) Conflict with existing zoning for, or cause rezoning of, forest land (as defined in Public Resources Code section 12220(g)), timberland (as defined by Public Resources Code section 4526), or timberland zoned Timberland Production (as defined by Government Code section 51104(g))?
- d) Result in the loss of forest land or conversion of forest land to non-forest use?
- e) Involve other changes in the existing environment which, due to their location or nature, could result in conversion of Farmland, to non-agricultural use or conversion of forest land to non-forest use?

No Impact. The proposed site is designated as *Farmland of Local Importance* by the State Farmland Mapping and Monitoring Program (FMMP).² No *Prime Farmland*, *Unique Farmland* or *Farmland of Local Importance*, or land under Williamson Act contracts occur in the proposed Project area.

The site is located within the City's Sphere of Influence and designated for residential uses. Any potential impacts resulting from the conversion of agricultural land were analyzed in the City of Dinuba General Plan EIR (SCH#2006091107).

The Project site is on the valley floor and as such, does not contain forest or timberland. As such, there are *no impacts*.

Mitigation Measures: None are required.

² California Important Farmland Finder, Department of Conservation. <https://maps.conservation.ca.gov/DLRP/CIFF/>. Accessed January 2024.

III. AIR QUALITY

Would the project:

	Potentially Significant Impact	Less than Significant With Mitigation Incorporation	Less than Significant Impact	No Impact
a. Conflict with or obstruct implementation of the applicable air quality plan?	<input type="checkbox"/>	<input type="checkbox"/>	<input checked="" type="checkbox"/>	<input type="checkbox"/>
b. Result in a cumulatively considerable net increase of any criteria pollutant for which the project region is non-attainment under an applicable federal or state ambient air quality standard?	<input type="checkbox"/>	<input type="checkbox"/>	<input checked="" type="checkbox"/>	<input type="checkbox"/>
c. Expose sensitive receptors to substantial pollutant concentrations?	<input type="checkbox"/>	<input type="checkbox"/>	<input checked="" type="checkbox"/>	<input type="checkbox"/>
d. Result in other emissions (such as those leading to odors or adversely affecting a substantial number of people)?	<input type="checkbox"/>	<input type="checkbox"/>	<input checked="" type="checkbox"/>	<input type="checkbox"/>

The following information was provided by an Air Quality, Health Risk Analysis, Greenhouse Gas, and Energy Technical Memorandum that was performed on behalf of the proposed Project by Johnson, Johnson & Miller Air Quality Consulting Services, report date January 1, 2024. The report can be read in its entirety in Appendix A.

RESPONSES

- a) Conflict with or obstruct implementation of the applicable air quality plan?
- b) Result in a cumulatively considerable net increase of any criteria pollutant for which the project region is non-attainment under an applicable federal or state ambient air quality standard?
- c) Expose sensitive receptors to substantial pollutant concentrations?

Less Than Significant Impact.

The Project site is located northwest corner of the intersection of Road 72 and West Sierra Way in unincorporated Tulare County, near the City of Dinuba, California. The Project includes the

construction and development of 75 single family residences with lot sizes ranging between 6,093 and 7,227 square feet. There is an existing home occupying a portion of the Project site, which will be demolished as part of the Project. The existing irrigation canal on the eastern portion of the Project site will be piped and undergrounded.

Air Quality Plans (AQPs) are plans for reaching attainment of air quality standards. The assumptions, inputs, and control measures are analyzed to determine if the Air Basin can reach attainment for the ambient air quality standards. The proposed Project site is located within the jurisdictional boundaries of the SJVAPCD. To show attainment of the standards, the SJVAPCD analyzes the growth projections in the Valley, contributing factors in air pollutant emissions and formations, and existing and adopted emissions controls. The SJVAPCD then formulates a control strategy to reach attainment that includes both State and SJVAPCD regulations and other local programs and measures. For projects that include stationary sources of emissions, the SJVAPCD relies on project compliance with Rule 2201—New and Modified Stationary Source Review to ensure that growth in stationary source emissions would not interfere with the applicable AQP. Projects exceeding the offset thresholds included in the rule are required to purchase offsets in the form of Emission Reduction Credits (ERCs).

The CEQA Guidelines indicate that a significant impact would occur if the project would conflict with or obstruct implementation of the applicable air quality plan. The GAMAQI indicates that projects that do not exceed SJVAPCD regional criteria pollutant emissions quantitative thresholds would not conflict with or obstruct the applicable AQP.

Contribution to Air Quality Violations

As discussed in Impact III(b) below, emissions of ROG, NO_x, CO, SO_x, PM₁₀, and PM_{2.5} associated with the proposed Project would not exceed the SJVAPCD's significance thresholds during the construction phase (see

Table). Similarly, emissions of ROG, NO_x, CO, SO_x, PM_{2.5} or PM₁₀ during operations would not exceed any applicable threshold of significance (see

Table 2). Therefore, regarding this criterion, the Project would be considered to have less than significant impact.

Air Quality Plan Control Measures

The AQP contains a number of control measures that are enforceable requirements through the adoption of rules and regulations. The following rules and regulations are relevant to the project:

Rule 4201—Particulate Matter Concentration. This rule shall apply to any source operation that emits or may emit dust, fumes, or total suspended particulate matter.

Rule 4601—Architectural Coatings. The purpose of this rule is to limit Volatile Organic Compounds (VOC) emissions from architectural coatings. Emissions are reduced by limits on VOC content and providing requirements on coatings storage, cleanup, and labeling. Only compliant components are available for purchase in the San Joaquin Valley.

Rule 4641—Cutback, Slow Cure, and Emulsified Asphalt, Paving and Maintenance Operations. The purpose of this rule is to limit VOC emissions from asphalt paving and maintenance operations. If asphalt paving will be used, then the paving operations will be subject to Rule 4641. This regulation is enforced on the asphalt provider.

Rule 4702—Internal Combustion Engines. The purpose of this rule is to limit the emissions of NO_x, carbon monoxide (CO), VOC, and sulfur oxides (SO_x) from internal combustion engines. If the project includes emergency generators, the equipment is required to comply with Rule 4702.

Regulation VIII—Fugitive PM₁₀ Prohibitions. This regulation is a control measure that is one main strategies from the 2006 PM₁₀ for reducing the PM₁₀ emissions that are part of fugitive dust. Projects over 10 acres are required to file a Dust Control Plan (DCP) containing dust control practices sufficient to comply with Regulation VIII. Rule 8021 regulates construction and demolition activities, road construction, bulk materials storage, paved and unpaved roads, carryout and trackout, etc. All development projects that involve soil disturbance are subject to at least one provision of the Regulation VIII series of rules.

Rule 9510—Indirect Source Review. This rule reduces the impact of NO_x and PM₁₀ emissions from growth within the SJVAB. The rule places application and emission reduction requirements on

development projects meeting applicability criteria in order to reduce emissions through on-site mitigation, off-site SJVAPCD-administered projects, or a combination of the two.

Conclusion

The Project would comply with all applicable CARB and SJVAPCD rules and regulations. Therefore, the Project complies with this criterion and would not conflict with or obstruct implementation of the applicable air quality attainment plan with regards to this criterion.

The Project's regional operational emissions would not exceed any applicable SJVAPCD prior to the incorporation of mitigation measures (see Impact III(b)). Therefore, the Project would be considered consistent with the existing AQPs.

Based on the findings above, the proposed Project would not conflict with or obstruct implementation of the applicable air quality plan. The impact would be *less than significant*.

Mitigation Measures: None are required.

b. Result in a cumulatively considerable net increase of any criteria pollutant for which the project region is non-attainment under an applicable federal or state ambient air quality standard?

Less Than Significant Impact. To result in a less than significant impact, emissions of nonattainment pollutants must be below the SJVAPCD's regional significance thresholds. This is an approach recommended by the SJVAPCD's in its GAMAQI. The SJVAB is in nonattainment for ozone, PM₁₀ (State only), and PM_{2.5}. Ozone is a secondary pollutant that can be formed miles from the source of emissions, through reactions of ROG and NO_x emissions in the presence of sunlight. Therefore, ROG and NO_x are termed ozone precursors. As such, the primary pollutants of concern during project construction and operation are ROG, NO_x, PM₁₀, and PM_{2.5}.

Since the SJVAB is nonattainment for ozone, PM₁₀, and PM_{2.5}, it is considered to have an existing significant cumulative health impact without the project. When this occurs, the analysis considers whether the project's contribution to the existing violation of air quality standards is cumulatively considerable. The SJVAPCD regional thresholds for NO_x, ROG/VOC, PM₁₀, or PM_{2.5} are applied as cumulative contribution thresholds. The SJVAPCD GAMAQI adopted in 2015 contains thresholds for CO, NO_x, ROG, SO_x, PM₁₀, and PM_{2.5}. Air pollutant emissions have both regional and localized effects. The Project's regional emissions are compared to the applicable SJVAPCD regional thresholds below to address if the Project would result in a cumulatively considerable net increase of any criteria pollutant (including ozone precursors) of concern.

Criteria Pollutant Emission Estimates

Construction Emissions (Regional)

Construction emissions associated with the development envisioned for the proposed Project are shown in

Table prior to the incorporation of any mitigation.³

Table 1
Summary of Construction Emissions of Criteria Air Pollutants – Unmitigated

Emissions Source	Emissions (Tons/Year)					
	ROG	NO _x	CO	SO _x	PM ₁₀	PM _{2.5}
Project Construction (2024)	0.21	1.9	1.99	< 0.01	0.22	0.13
Project Construction (2025)	0.64	1.32	1.73	< 0.01	0.10	0.06
Total Construction Duration (2024-2025)						
Project Total	0.85	3.22	3.72	< 0.01	0.32	0.19
Significance Thresholds	10	10	100	27	15	15
Exceed Significance Thresholds?	No	No	No	No	No	No

³ Dinuba Empire Estates – County of Tulare Project in Dinuba. Air Quality, Health Risk Analysis, Greenhouse Gas, and Energy Technical Memorandum. Johnson Johnson and Miller Air Quality Consulting Services. Prepared on January 1, 2024. Appendix A.

Notes:

PM₁₀ and PM_{2.5} emissions are from the mitigated output to reflect compliance with Regulation VIII—Fugitive PM₁₀ Prohibitions. Source of Emissions: Modeling Assumptions and CalEEMod Output Files (Appendix A).

Source of Thresholds: San Joaquin Valley Air Pollution Control District (SJVAPCD). 2015. Guidance for Assessing and Mitigating Air Quality Impacts. February 19. Website: <https://www.valleyair.org/transportation/GAMAQI-2015/FINAL-DRAFT-GAMAQI.PDF>. Accessed September, 2023.

As shown in

Table above, emissions from construction activities associated with the proposed Project would fall below the significance thresholds. Therefore, regional and cumulative impacts associated with construction of the proposed Project are less than significant.

Operational Emissions (Regional)

Operational emissions occur over the lifetime of the project. The SJVAPCD considers permitted and non-permitted emission sources separately when making significance determinations. In addition, the annual operational emissions are also considered separately from construction emissions. Operational emissions associated with the proposed Project are shown in

Table 2.⁴ Operational emissions were estimated using a full buildout scenario in the earliest year of operations (2025), which provides a conservative estimate of emissions and resulting potential impacts.

⁴ Ibid.

Table 2
Summary of Operational Emissions of Criteria Air Pollutants – Unmitigated

Source	Emissions (tons/year)					
	ROG	NO _x	CO	SO _x	PM ₁₀	PM _{2.5}
Area	0.66	0.03	0.39	< 0.01	< 0.01	< 0.01
Energy	0.01	0.13	0.06	< 0.01	0.01	0.01
Mobile (Automobiles)	0.46	0.46	3.58	0.01	0.68	0.18
Annual Total	1.13	0.62	4.03	0.01	0.69	0.19
Significance Thresholds	10	10	100	27	15	15
Exceed Significance Thresholds?	No	No	No	No	No	No
Notes: Emissions were quantified using CalEEMod based on project details and earliest operational year for the proposed Project. Source: Modeling Assumptions and CalEEMod Output Files (Appendix A).						

As shown in

Table 2, operational emissions would not exceed the applicable SJVAPCD thresholds of significance for ROG, NO_x, CO, SO_x, PM₁₀, or PM_{2.5}. Therefore, the impact from operations of the Project would be *less than significant*.

Conclusion

As shown in

Table , the Project's regional emissions would not exceed the applicable regional criteria pollutant emissions quantitative thresholds during Project construction. During operations, the Project would not exceed the applicable regional criteria pollutant emissions quantitative thresholds (see

Table 2). Therefore, the impact would be *less than significant*.

Mitigation Measures: None are required.

c. Expose sensitive receptors to substantial pollutant concentrations?

Less Than Significant Impact. Emissions occurring at or near the Project have the potential to create a localized impact that could expose sensitive receptors to substantial pollutant concentrations. Sensitive receptors are considered land uses or other types of population groups that are more sensitive to air pollution than others due to their exposure. Sensitive population groups include children, the elderly, the acutely and chronically ill, and those with cardio-respiratory diseases. The SJVAPCD considers a sensitive receptor to be a location that houses or attracts children, the elderly, people with illnesses, or others who are especially sensitive to the effects of air pollutants. Examples of sensitive receptors include hospitals, residences, convalescent facilities, and schools.

The closest existing sensitive receptors to the Project site include residential receptors, the closest of which include an existing single-family home located within approximately 120 feet west of the Project boundary and an existing single-family home located approximately 130 feet north of the northwest portion of the Project boundary. See Appendix A - Construction Health Risk Assessment and Operational Health Risk Screening for a graphical representation of the sensitive receptor locations within approximately ¼-mile of the Project site.

Localized Impacts

Emissions occurring at or near the project have the potential to create a localized impact also referred to as an air pollutant hotspot. Localized emissions are considered significant if when combined with

background emissions, they would result in exceedance of any health-based air quality standard. In locations that already exceed standards for these pollutants, significance is based on a significant impact level (SIL) that represents the amount that is considered a cumulatively considerable contribution to an existing violation of an air quality standard. The pollutants of concern for localized impact in the SJVAB are NO₂, SO_x, and CO.

The SJVAPCD has provided guidance for screening localized impacts in the GAMAQI that establishes a screening threshold of 100 pounds per day of any criteria pollutant. If a project exceeds 100 pounds per day of any criteria pollutant, then ambient air quality modeling would be necessary. If the project does not exceed 100 pounds per day of any criteria pollutant, then it can be assumed that it would not cause a violation of an ambient air quality standard.

Construction: Localized Concentrations of PM₁₀, PM_{2.5}, CO, SO_x, and NO_x

Local construction impacts would be short-term in nature lasting only during the duration of construction. As shown in **Error! Reference source not found.** below, on-site construction emissions would be less than 100 pounds per day for each of the criteria pollutants.⁵ To present a conservative estimate, on-site emissions for on-road construction vehicles were included in the localized analysis. Based on the SJVAPCD's guidance, the construction emissions would not cause an ambient air quality standard violation.

Table 3
Localized Concentrations of PM₁₀, PM_{2.5}, CO, and NO_x for Construction – Unmitigated

Emission Source	On-site Emissions (pounds per day)					
	ROG	NO _x	CO	SO _x	PM ₁₀	PM _{2.5}

⁵ Ibid.

Highest Daily (2024)	3.74	36.05	33.21	0.06	9.46	5.43
Highest Daily (2025)	49.74	11.58	14.84	0.03	0.85	0.46
Total Construction Duration						
Highest Daily Maximum	49.74	36.05	33.21	0.06	9.46	5.43
Significance Thresholds	—	100	100	100	100	100
Exceed Significance Thresholds?	—	No	No	No	No	No
<p>Note: Overlap of construction activities is based on the construction schedule shown in Appendix A. Source of Emissions: Modeling Assumptions and CalEEMod Output Files (Appendix A). Maximum daily emissions represent the maximum daily emissions between the Summer and Winter scenarios. Source of Thresholds: San Joaquin Valley Air Pollution Control District (SJVAPCD). 2015. Guidance for Assessing and Mitigating Air Quality Impacts. February 19. Website: https://www.valleyair.org/transportation/GAMAQI-2015/FINAL-DRAFT-GAMAQI.PDF. Accessed September 2023.</p>						

Operation: Localized Concentrations of PM₁₀, PM_{2.5}, CO, SO_x, and NO_x

Localized impacts could occur in areas with a single large source of emissions such as a power plant or with multiple sources concentrated in a small area such as a distribution center. The maximum daily operational emissions would occur at project buildout, which was modeled for the year 2025 (the earliest year of operations). Operational emissions include those generated on-site by area sources such as consumer products and landscape maintenance, energy use from natural gas combustion, and motor vehicles operation at the Project site. Motor vehicle emissions are estimated for on-site operations using trip lengths for on-site travel and ¼-mile of off-site emissions.⁶

Table 4
 Localized Concentrations of PM₁₀, PM_{2.5}, CO, and NO_x for Operations

Source	On-site Emissions (pounds per day)					
	ROG	NO _x	CO	SO _x	PM ₁₀	PM _{2.5}

⁶ Ibid.

Area	3.83	0.62	4.51	< 0.01	0.05	0.05
Energy	0.04	0.74	0.31	< 0.01	0.06	0.06
Mobile (Automobiles)	2.67	0.97	6.64	< 0.01	0.26	0.07
Total	6.54	2.33	11.46	< 0.01	0.37	0.18
Significance Thresholds	—	100	100	100	100	100
Exceed Significance Thresholds?	—	No	No	No	No	No

Source of Emissions: Modeling Assumptions and CalEEMod Output Files (Appendix A).
 Source of Thresholds: San Joaquin Valley Air Pollution Control District (SJVAPCD). 2015. Guidance for Assessing and Mitigating Air Quality Impacts. February 19. Website: <https://www.valleyair.org/transportation/GAMAQI-2015/FINAL-DRAFT-GAMAQI.PDF>. Accessed September, 2023.

Toxic Air Contaminants

Construction – Health Risk Analysis

Project construction would involve the use of diesel-fueled vehicles and equipment that emit DPM, which is considered a TAC. The SJVAPCD’s current threshold of significance for TAC emissions is an increase in cancer risk for the maximally exposed individual of 20 in a million (formerly 10 in a million). The SJVAPCD’s 2015 GAMAQI does not currently recommend analysis of TAC emissions from project construction activities, but instead focuses on projects with operational emissions that would expose sensitive receptors over a typical lifetime of 70 years. In addition, the most intense construction activities of the Project’s construction would occur during site preparation and grading phases over a short period. There are no conditions unique to the Project site that would require more intense construction activity compared to typical development. Examples of situations that would warrant closer scrutiny may include sites that would require extensive excavation and hauling due to existing site conditions. Building construction typically requires limited amounts of diesel equipment relative to site clearing activities. Nonetheless, a construction HRA was prepared as part of this analysis.

The results of the HRA prepared for Project construction for cancer risk and long-term chronic cancer risk are summarized below. Construction emissions were estimated assuming adherence to all applicable rules, regulations, and Project design features. The construction emissions were assumed to be distributed over the Project area with a working schedule of eight hours per day and five days per week. Emissions were adjusted by a factor of 4.2 to convert for use with a 24-hour-per-day, 365 day-per-year averaging period. Health risk calculations were completed using HARP2. Detailed parameters and complete calculations are included in Attachment B of Appendix A.

The estimated health and hazard impacts at the Maximally Exposed Receptor (MER) from the Project’s construction emissions are provided in **Error! Reference source not found.**⁷

Table 5
Summary of the Health Impacts from Unmitigated Construction of the Project

Exposure Scenario	Maximum Cancer Risk (Risk per Million)	Chronic Non-Cancer Hazard Index	Acute Non-Cancer Hazard Index
Risks and Hazards at the MER			
Risks and Hazards at the MER (Construction Only)	7.7	0.00512	0.00
Risks and Hazards at the MER (Construction Plus Operations)	8.66	0.01155	0.00
Significance Threshold	20	1	1
Threshold Exceeded in Any Scenario?	No	No	No
MER = Maximally Exposed Receptor Project MER: Receptor #76 (36.54112, -119.416993) Source: Construction Health Risk Assessment and Operational Health Risk Screening (Appendix A).			

As shown in **Error! Reference source not found.**, calculated health metrics from the proposed Project’s construction DPM emissions would not exceed the cancer risk significance threshold or non-cancer hazard index significance threshold at the MER. Therefore, the proposed Project would not result in a significant impact on nearby sensitive receptors from TACs during construction.

Operations

Unlike warehouses or distribution centers, the daily vehicle trips generated by the proposed residential Project would be primarily generated by passenger vehicles. Passenger vehicles typically use gasoline engines rather than the diesel engines that are found in heavy-duty trucks. Gasoline-powered vehicles do emit TACs in the form of toxic organic gases, some of which are carcinogenic. Compared to the combustion of diesel, the combustion of gasoline has relatively low emissions of TACs. Thus, residential development projects typically produce limited amounts of TAC emissions during operation. Nonetheless, it is anticipated that there would be some heavy-duty trucks visiting the Project site during operations. Consistent with SJVAPCD guidance, an operational prioritization screening analysis was completed for the proposed Project.

⁷ Ibid.

Operational DPM emissions from diesel trucks were estimated using EMFAC2021 emission factors and estimated truck travel and idling at the Project site. The emissions were entered into the SJVAPCD Prioritization Screening Tool to determine the risk scores, with complete calculations and assumptions included as part of Appendix A. The results of the screening analysis are provided in Table 6.⁸

Table 6
Prioritization Tool Health Risk Screening Results

Impact Source	Cancer Risk Score	Chronic Risk Score	Acute Risk Score
Diesel Trucks	0.96	0.00643	0.00
Total Risk from Project Operations	0.96	0.00643	0.00
Screening Risk Score Threshold	10	1	1
Screening Thresholds Exceeded?	No	No	No

Source: Construction Health Risk Assessment and Operational Health Risk Screening (Attachment B of Appendix A)

As shown in Table 6, the Project would not exceed the cancer risk or chronic hazard screening threshold levels during project operations. The primary source of the emissions responsible for chronic risk are from diesel trucks. DPM does not have an acute risk factor. Since the project does not exceed the applicable SJVAPCD screening thresholds for cancer risk, acute risk, or chronic risk, this impact would be less than significant.

Valley Fever

Valley fever, or coccidioidomycosis, is an infection caused by inhalation of the spores of the fungus, *Coccidioides immitis* (*C. immitis*). The spores live in soil and can live for an extended time in harsh environmental conditions. Activities or conditions that increase the amount of fugitive dust contribute to greater exposure, and they include dust storms, grading, and recreational off-road activities.

The San Joaquin Valley is considered an endemic area for Valley fever. During 2000–2018, a total of 65,438 coccidioidomycosis cases were reported in California; median statewide annual incidence was 7.9 per 100,000 population and varied by region from 1.1 in Northern and Eastern California to 90.6 in the Southern San Joaquin Valley, with the largest increase (15-fold) occurring in the Northern San Joaquin Valley. Incidence has been consistently high in six counties in the Southern San Joaquin Valley (Fresno, Kern, Kings, Madera, Tulare, and Merced counties) and Central Coast (San Luis Obispo

⁸ Ibid.

County) regions.⁹ California experienced 7,517 new probable or confirmed cases of Valley fever in 2022. A total of 319 suspect, probable, and confirmed Valley fever cases were reported in Tulare County in 2022.¹⁰

The distribution of *C. immitis* within endemic areas is not uniform and growth sites are commonly small (a few tens of meters) and widely scattered. Known sites appear to have some ecological factors in common suggesting that certain physical, chemical, and biological conditions are more favorable for *C. immitis* growth. Avoidance, when possible, of sites favorable for the occurrence of *C. immitis* is a prudent risk management strategy. Listed below are ecologic factors and sites favorable for the occurrence of *C. immitis*:

- 1) Rodent burrows (often a favorable site for *C. immitis*, perhaps because temperatures are more moderate and humidity higher than on the ground surface)
- 2) Old (prehistoric) Indian campsites near fire pits
- 3) Areas with sparse vegetation and alkaline soils
- 4) Areas with high salinity soils
- 5) Areas adjacent to arroyos (where residual moisture may be available)
- 6) Packrat middens
- 7) Upper 30 centimeters of the soil horizon, especially in virgin undisturbed soils
- 8) Sandy, well-aerated soil with relatively high water-holding capacities

Sites within endemic areas less favorable for the occurrence of *C. immitis* include:

- 1) Cultivated fields
- 2) Heavily vegetated areas (e.g., grassy lawns)
- 3) Higher elevations (above 7,000 feet)
- 4) Areas where commercial fertilizers (e.g., ammonium sulfate) have been applied
- 5) Areas that are continually wet
- 6) Paved (asphalt or concrete) or oiled areas
- 7) Soils containing abundant microorganisms
- 8) Heavily urbanized areas where there is little undisturbed virgin soil.¹¹

⁹ Centers for Disease Control and Prevention (CDC). 2020. Regional Analysis of Coccidioidomycosis Incidence—California, 2000–2018. Website: https://www.cdc.gov/mmwr/volumes/69/wr/mm6948a4.htm?s_cid=mm6948a4_e. Accessed June 16, 2023.

¹⁰ California Department of Public Health (CDPH). 2021. Coccidioidomycosis in California Provisional Monthly Report January – April 2023 (as of April 30, 2023). Website: <https://www.cdph.ca.gov/Programs/CID/DCDC/CDPH%20Document%20Library/CocciinCAProvisionalMonthlyReport.pdf>. Accessed June 16, 2023.

¹¹ United States Geological Survey (USGS). 2000. Operational Guidelines (Version 1.0) for Geological Fieldwork in Areas Endemic for Coccidioidomycosis (Valley Fever), 2000, Open-File Report 2000-348. Website: <https://pubs.usgs.gov/of/2000/0348/pdf/of00-348.pdf>.

The Project is situated on a site previously disturbed that does not provide a suitable habitat for spores. Specifically, the Project site had been previously disturbed and has some vegetation cover in the form of shrubbery and existing landscaping. Therefore, implementation of the proposed Project would have a low probability of the site having *C. immitis* growth sites and exposure to the spores from disturbed soil.

Although conditions are not favorable, construction activities could generate fugitive dust that contains *C. immitis* spores. The Project will minimize the generation of fugitive dust during construction activities by complying with SJVAPCD's Regulation VIII. Therefore, this regulation, combined with the relatively low probability of the presence of *C. immitis* spores would reduce Valley fever impacts to less than significant.

During operations, dust emissions are anticipated to be relatively small because most of the Project area where operational activities would occur would be occupied by the proposed single-family homes, landscaping, pavement, and internal streets. This condition of the Project being built-up would lessen the possibility of the Project site providing habitat suitable for *C. immitis* spores and for generating fugitive dust that may contribute to Valley fever exposure. Impacts would be less than significant.

Naturally Occurring Asbestos

Review of the map of areas where naturally occurring asbestos in California are likely to occur found no such areas in the immediate Project area. Therefore, development of the Project is not anticipated to expose receptors to naturally occurring asbestos.¹² Impacts would be less than significant.

Operations—The Project's Potential to Locate Sensitive Receptor Near Existing Sources of TACs

As a residential development project, the Project would locate sensitive receptors (future residents) to a site where future Project residents could be subject to existing sources of TACs at the Project site. However, the California Supreme Court concluded in *California Building Industry Association (CBIA) v. Bay Area Air Quality Management District (BAAQMD)* that agencies subject to CEQA are not required to analyze the impact of existing environmental conditions on a Project's future users or residents. Therefore, this impact will not be further addressed in this document.

Accessed December, 2023.

¹² U.S. Geological Survey. 2011. Van Gosen, B.S., and Clinkenbeard, J.P. California Geological Survey Map Sheet 59. Reported Historic Asbestos Mines, Historic Asbestos Prospects, and Other Natural Occurrences of Asbestos in California. Open-File Report 2011-1188 Website: <https://pubs.usgs.gov/of/2011/1188/>. Accessed December, 2023.

Conclusion

In summary, the Project would not exceed SJVAPCD localized emission daily screening levels for any criteria pollutant. The Project is not a significant source of TAC emissions during construction or operations. The Project is not in an area with suitable habitat for Valley fever spores and is not in an area known to have naturally occurring asbestos. Therefore, the Project would not result in significant impacts to sensitive receptors and impacts are *less than significant*.

d) Result in other emissions (such as those leading to odors adversely affecting a substantial number of people?

Less than Significant Impact. Two situations create a potential for odor impact. The first occurs when a new odor source is located near an existing sensitive receptor. The second occurs when a new sensitive receptor locates near an existing source of odor. Odor impacts on residential areas and other sensitive receptors, such as hospitals, day-care centers, schools, etc. warrant the closest scrutiny, but consideration should also be given to other land uses where people may congregate, such as recreational facilities, worksites, and commercial areas.

Although the Project is less than one mile from the nearest sensitive receptor, the Project is not expected to be a significant source of odors. The screening levels for these land use types are shown in

Table 7.

Table 7
Screening Levels for Potential Odor Sources

Odor Generator	Screening Distance
Wastewater Treatment Facilities	2 miles
Sanitary Landfill	1 mile
Transfer Station	1 mile
Composting Facility	1 mile
Petroleum Refinery	2 miles
Asphalt Batch Plant	1 mile
Chemical Manufacturing	1 mile
Fiberglass Manufacturing	1 mile
Painting/Coating Operations (e.g., auto body shop)	1 mile
Food Processing Facility	1 mile
Feed Lot/Dairy	1 mile
Rendering Plant	1 mile
Source of Thresholds: San Joaquin Valley Air Pollution Control District (SJVAPCD). 2015. Guidance for Assessing and Mitigating Air Quality Impacts. February 19. Website: https://www.valleyair.org/transportation/GAMAQI-2015/FINAL-DRAFT-GAMAQI.PDF . Accessed September 2023.	

Construction

During construction, various diesel-powered vehicles and equipment in use on-site would create localized odors. These odors would be temporary and intermittent, which would decrease the likelihood of the odors concentrating in a single area or lingering for any notable period of time. As such, these odors would likely not be noticeable for extended periods of time beyond the Project's site boundaries. The potential for odor impacts from construction of the proposed Project would, therefore, be less than significant.

Operations

Project as a Potential Odor Generator

The development of the proposed Project would not substantially increase objectionable odors in the area. Minor sources of odors that would be associated with typical residential land uses, such as exhaust from mobile sources (including diesel-fueled vehicles), are known to have temporary and less concentrated odors. Considering the low intensity of potential odor emissions, the proposed Project's operational activities would not expose receptors to objectionable odor emissions. Therefore, the proposed Project would not be considered to be a generator of objectionable odors during operations. As such, impacts would be *less than significant*.

Project as a Receptor

The City's wastewater treatment plant is approximately ¼ mile from the proposed Project; however, with the *CBIA v. BAAQMD* ruling, analysis of odor impacts on receivers is not required for CEQA compliance unless the project would exacerbate the impact. As discussed above, the Project would not be considered a major source of odors during construction or operation. Therefore, no further analysis is needed. Considering this information, impacts would be *less than significant*.

Mitigation Measures: None are required.

IV. BIOLOGICAL RESOURCES

Would the project:

	Potentially Significant Impact	Less than Significant With Mitigation Incorporation	Less than Significant Impact	No Impact
a. Have a substantial adverse effect, either directly or through habitat modifications, on any species identified as a candidate, sensitive, or special status species in local or regional plans, policies, or regulations, or by the California Department of Fish and Game or U.S. Fish and Wildlife Service?	<input type="checkbox"/>	<input checked="" type="checkbox"/>	<input type="checkbox"/>	<input type="checkbox"/>
b. Have a substantial adverse effect on any riparian habitat or other sensitive natural community identified in local or regional plans, policies, regulations, or by the California Department of Fish and Game or U.S. Fish and Wildlife Service?	<input type="checkbox"/>	<input type="checkbox"/>	<input checked="" type="checkbox"/>	<input type="checkbox"/>
c. Have a substantial adverse effect on federally protected wetlands as defined by Section 404 of the Clean Water Act (including, but not limited to, marsh, vernal pool, coastal, etc.) through direct removal, filling, hydrological interruption, or other means?	<input type="checkbox"/>	<input type="checkbox"/>	<input checked="" type="checkbox"/>	<input type="checkbox"/>
d. Interfere substantially with the movement of any native resident or migratory fish or wildlife species or with established native resident or migratory wildlife corridors, or impede the use of native wildlife nursery sites?	<input type="checkbox"/>	<input checked="" type="checkbox"/>	<input type="checkbox"/>	<input type="checkbox"/>

- e. Conflict with any local policies or ordinances protecting biological resources, such as a tree preservation policy or ordinance?
- f. Conflict with the provisions of an adopted Habitat Conservation Plan, Natural Community Conservation Plan, or other approved local, regional, or state habitat conservation plan?

ENVIRONMENTAL SETTING

The proposed Project site is located in a portion of the central San Joaquin Valley that has, for decades, experienced intensive agricultural and urban disturbances. Current agricultural endeavors in the region include dairy, cattle, groves, and row crops.

Like most of California, the Central San Joaquin Valley experiences a Mediterranean climate. Warm dry summers are followed by cool moist winters. Summer temperatures usually exceed 90 degrees Fahrenheit, and the relative humidity is generally very low. Winter temperatures rarely raise much above 70 degrees Fahrenheit, with daytime highs often below 60 degrees Fahrenheit. Annual precipitation within the proposed Project area is about 10 inches, almost 85% of which falls between the months of October and March. Nearly all precipitation falls in the form of rain and storm-water readily infiltrates the soils of the surrounding the sites.

Native plant and animal species once abundant in the region have become locally extirpated or have experienced large reductions in their populations due to conversion of upland, riparian, and aquatic habitats to agricultural and urban uses. Remaining native habitats are particularly valuable to native wildlife species including special status species that still persist in the region.

A Biological Resource Evaluation (BRE) was performed on behalf of the Project by Colibri Ecological Consulting in December 2023 and is the basis of the impact analysis. The BRE report can be found in its entirety in Appendix B.

A search of the California Natural Diversity Database (CNDDDB) and a field reconnaissance survey of the Project site was conducted as part of the BRE. The Project site and a 50-foot buffer surrounding the Project site were walked and thoroughly inspected to evaluate and document the potential for the area to support state- or federally protected resources. All plants except those under cultivation or planted in residential areas and all vertebrate wildlife species observed within the survey area were identified

and documented. The survey area was evaluated for the presence of regulated habitats, including lakes, streams, and other waters using methods described in the *Wetlands Delineation Manual* and regional supplement and as defined by the CDFW (<https://www.wildlife.ca.gov/conservation/lisa>) or under the Porter-Cologne Water quality Control Act. An additional buffer of 0.5 miles around the Project site was inspected for potential nesting sites for special-status raptors. The 0.5-mile buffer was surveyed by driving public roads and identifying the presence of large trees or other potentially suitable substrates for nesting raptors as well as open areas that could provide foraging habitat.

One potentially regulated habitat, Horseman Ditch, was found in the Project area: an earthen agricultural drainage ditch along the eastern boundary of the Project. Horseman Ditch is listed in the National Wetlands Inventory as an intermittent riverine system with a classification of R4SBCx, which means riverine, intermittent, streambed, seasonally flooded, and excavated.¹³ During the BRE survey, Horseman Ditch had wet soil across its length within the Project site and contained standing water in the southernmost portion of the Project site. As a surface water in California, Horseman Ditch it is likely regulated by the SWRCB. As a waterway in California, it may also be regulated by the CDFW. And as it appears to be a tributary of the St. Johns River, of a water of the United States, it may fall under the regulatory jurisdiction of the USACE. It is not considered a wetland, riparian habitat, or sensitive natural habitat.

RESPONSES

- a) Have a substantial adverse effect, either directly or through habitat modifications, on any species identified as a candidate, sensitive, or special status species in local or regional plans, policies, or regulations, or by the California Department of Fish and Game or U.S. Fish and Wildlife Service?

Less Than Significant Impact with Mitigation. A CNDDDB search for records of special-status species from the Tulare 7.5- minute USGS topographic quadrangle and the eight surrounding quadrangles produced 200 records of 39 species (see Table 1 of Appendix B). Of those 39 species, seven were not considered further because they are not CEQA-recognized as special-status species by state or federal regulatory agencies or public interest groups or are considered extirpated in California. Of the remaining 32 species, seven are known from within 5 miles of the Project site. Of those seven species, four could occur on or near the Project site (Table 1). Those include burrowing owl (*Athene cunicularia*—

¹³ Colibri Ecological Consulting, Biological Resource Evaluation. December 2023. Appendix B.

SSSC), Swainson’s hawk (*Buteo swainsoni*—ST), pallid bat (*Antrozous pallidus*—SSSC), and Sanford’s arrowhead (*Sagittaria sanfordii*—1B.2). One species not identified in the nine-quad search, American badger (*Taxidea taxus*—SSSC) was determined to be present on the Project site based on sign observed during the 29 November 2023 reconnaissance survey. Potential impacts to these species are further discussed below.

Stanford’s Arrowhead

Stanford’s arrowhead is an aquatic emergent, rhizomatous perennial herb in the family Alismataceae with a California Rare Plant Rank (CRPR) of 1B.2. It is endemic to the Central Valley of California where it occupies ponds, ditches, sloughs, marshes, and slow-moving rivers below 984 feet elevation; it flowers May–October.

There are two CNDDDB occurrence records from 2001 known from within five miles of the Project site. This species was not detected during the reconnaissance survey, which occurred outside the flowering period. Horsman Ditch, along the east side of the Project site, could support this species. However, anthropogenic disturbance associated with agricultural operations limits habitat quality. Therefore, the potential for this species to occur on the Project site is low; however, Mitigation Measure BIO-1 is included to further reduce potential impacts to less than significant.¹⁴

Swainson’s Hawk

Swainson’s hawk is a state listed as threatened raptor in the family Accipitridae. It is a migratory breeding resident of Central California. It uses open areas including grassland, sparse shrubland, pasture, open woodland, and annual agricultural fields such as grain and alfalfa to forage on small mammals, birds, and reptiles. After breeding, it eats mainly insects, especially grasshoppers. Swainson’s hawks build small to medium-sized nests in medium to large trees near foraging habitat. The nesting season begins in March or April in Central California when this species returns to its breeding grounds from wintering areas in Mexico and Central and South America. Nest building commences within one to two weeks of arrival to the breeding area and lasts about one week. One to four eggs are laid and incubated for about 35 days. Young typically fledge in about 38–46 days and tend to leave the nest territory within 10 days of fledging. Swainson’s hawks depart for the non-breeding grounds between August and September.¹⁵

Seven CNDDDB occurrence records of Swainson’s hawk, from 1926–2017, were found in the nine-quad search; no CNDDDB occurrence records were found within five miles of the Project site. The fallow field

¹⁴ Colibri Ecological Consulting, Biological Resource Evaluation. December 2023. Appendix B.

¹⁵ Ibid.

on the Project site and surrounding lands provide foraging habitat for Swainson's hawk, and potential nest trees were observed within 0.5 miles of the Project site. Therefore, there is a moderate potential for Swainson's hawk to nest within 0.5 miles of the Project site.¹⁶ Mitigation Measures BIO-2 and BIO-3 are included to reduce potential impacts to less than significant.

Burrowing Owl

Burrowing owl is a member of the family Strigidae recognized as a species of special concern by the CDFW. Burrowing owl occurs primarily in grassland but can persist and even thrive in agricultural or other developed and disturbed areas. Burrowing owl depends on burrow systems excavated by other species such as California ground squirrel (*Otospermophilus beecheyi*) and American badger (*Taxidea taxus*). Burrowing owls use burrows for protection from predators, weather, as roosting sites, and dwellings to raise young. It commonly perches outside burrows on mounds of soil or nearby fence posts. Prey types include insects, especially grasshoppers and crickets, small mammals, frogs, toads, and lizards. The nesting season begins in March, and incubation lasts 28–30 days. Adults can live up to 8 years in the wild.¹⁷

There is one CNDDDB occurrence record of burrowing owl from within five miles of the Project site. An additional 12 CNDDDB occurrence records were found in the nine-quad search. The nearest CNDDDB occurrence record of burrowing owl is from an agricultural field 0.2 miles southwest of the Project site. Ground squirrel burrows that could support this species were scattered throughout the Project site, and the Project site provides foraging habitat. However, the habitat is routinely disturbed, and no sign of burrowing owl was detected during the 29 November 2023 reconnaissance survey. Therefore, the potential for this species to occur on the Project site is low; however, Mitigation Measure BIO-4 is included to reduce potential impacts to less than significant.¹⁸

American Badger

American badger is a medium-sized fossorial carnivore in the family Mustelidae, occurring throughout much of California. American badger resides primarily in open, early succession habitats such as arid and open shrubland, forest, and herbaceous habitat types with sparse vegetative cover and sandy soils. Friable soil is a key microhabitat requirement for this species, which digs burrows for shelter.

¹⁶ Colibri Ecological Consulting, Biological Resource Evaluation. December 2023. Appendix B.

¹⁷ Ibid.

¹⁸ Ibid.

badger is carnivorous and preys on fossorial rodents. American badger has a large home range and is not known to migrate. The American badger breeding season spans summer to early fall. Once common in California, American badger is now considered a Species of Special Concern, primarily due to human encroachment including industrialized agriculture and urban development. Additional threats to American badger include vehicle strikes, disease, and secondary poisoning via rodenticides.¹⁹

There were no CNDDDB occurrence records of American badger within the nine-quad search of the Project site. However, during the 29 November 2023 reconnaissance survey, one burrow large enough to support this species was observed in the south-central portion of the Project site. The side walls of the burrow entrance exhibited the distinctive long, sweeping claw marks of an American badger, as shown below.



No sign of occupation or recent use of the burrow, such as scat or the remains of prey items, were found in the immediate vicinity of the burrow, which probably indicates this burrow is no longer occupied by a badger. It is also possible that a badger never occupied this burrow but was attempting to dig out and depredate a ground squirrel in the burrow. Regardless, due to the presence American

¹⁹ Colibri Ecological Consulting, Biological Resource Evaluation. December 2023. Appendix B.

badger sign, this species is considered present on the Project site and Mitigation Measure BIO-5 is included to reduce potential impacts to less than significant.

Pallid Bat

Pallid bat is a member of the family Vespertilionidae and is recognized as a Species of Special Concern by the CDFW. It is widespread in the western United States from southern British Columbia, Canada to northern Baja California, Mexico. In California, pallid bat is locally common year-round at low elevations, where it occupies dry, open areas in grassland, shrubland, woodland, and forest. Pallid bat is nocturnal and roosts during the day in caves, crevices in rocky outcrops, mines, and occasionally tree hollows and buildings; night roosts tend to be in more open areas including porches. It forages almost exclusively on the ground, where it preys on insects, arachnids, beetles, moths, and scorpions; few prey items are taken aerially. Pallid bat hibernates during winter, usually near a day roost that it occupies in summer.²⁰

There is one CNDDDB occurrence record of pallid bat from within five miles of the Project site (CDFW 2023). Accessible roosting habitat was observed in an unoccupied, dilapidated residence near the western boundary of the Project site, and the surrounding agricultural lands may provide foraging habitat. This species has a moderate potential to occur on or near the Project site.

Conclusion

Construction activities such as excavating, trenching, or using other heavy equipment that disturbs or harms a special-status species or substantially modifies its habitat could constitute a significant impact. Mitigation Measures BIO-1 to BIO-6 are required to reduce the potential impacts to *less than significant* levels.

Mitigation Measures:

BIO-1. Protect Sanford's arrowhead.

1. A qualified biologist shall conduct a pre-construction survey for Sanford's arrowhead at Horseman Ditch. The survey shall be timed to coincide with the May–October blooming period of the species.
2. If Sanford's arrowhead is detected, the qualified biologist shall establish an exclusion zone of 50 feet between any population and the area of direct or indirect impacts. If a 50-foot exclusion zone

²⁰ Colibri Ecological Consulting, Biological Resource Evaluation. December 2023. Appendix B.

cannot be established, a site-specific plan to minimize the potential for Project activities to affect individual plants shall be developed by the qualified biologist and implemented in consultation with the CDFW. Such a plan could involve conducting work after plant senescence and salvaging and relocating affected plants and associated topsoil.

BIO-2. Protect nesting Swainson's hawks.

1. To the extent practicable, construction shall be scheduled to avoid the Swainson's hawk nesting season, which extends from March through August.
2. If it is not possible to schedule construction between September and February, a qualified biologist shall conduct surveys for Swainson's hawk in accordance with the Swainson's Hawk Technical Advisory Committee's Recommended Timing and Methodology for Swainson's Hawk Nesting Surveys in California's Central Valley (SWTAC 2000, Appendix E). These methods require six surveys, three in each of the two survey periods, prior to project initiation. Surveys shall be conducted within a minimum 0.5-mile radius around the Project site.
3. If an active Swainson's hawk nest is found within 0.5 miles of the Project site, and the qualified biologist determines that Project activities would disrupt the nesting birds, a construction-free buffer or limited operating period shall be implemented in consultation with the CDFW.

BIO-3. Compensate for loss of Swainson's hawk foraging habitat.

Compensate for loss of Swainson's hawk foraging habitat (i.e., agricultural lands on the Project site). In accordance with the CDFW Staff Report Regarding Mitigation for Impacts to Swainson's Hawks (*Buteo swainsoni*) in the Central Valley of California (CDFG 1994, Appendix F of Appendix B). The CDFW requires that projects adversely affecting Swainson's hawk foraging habitat provide Habitat Management (HM) lands to the department. Projects within one mile of an active nest shall provide one acre of HM lands for each acre of development authorized (1:1 ratio). Projects within five miles of an active nest but greater than one mile from the nest shall provide 0.75 acres of HM lands for each acre of urban development authorized (0.75:1 ratio). And projects within 10 miles of an active nest but greater than five miles from an active nest shall provide 0.5 acres of HM lands for each acre of urban development authorized (0.5:1 ratio). No compensation is required if an active nest is not found within 10 miles of the Project site.

BIO-4. Protect burrowing owl.

1. Conduct focused burrowing owl surveys to assess the presence/absence of burrowing owl in accordance with the Staff Report on Burrowing Owl Mitigation (CDFG 2012) and Burrowing Owl Survey Protocol and Mitigation Guidelines (CBOC 1997). These involve conducting four pre-construction survey visits.

2. If a burrowing owl or sign of burrowing owl use (e.g., feathers, guano, pellets) is detected on or within 500 feet of the Project site, and the qualified biologist determines that Project activities would disrupt the owl(s), a construction-free buffer, limited operating period, or passive relocation shall be implemented in consultation with the CDFW.

BIO-5. Protect American badger.

Within 30 days prior to the start of construction or ground disturbing activities, a qualified biologist shall survey the Project site for American badger. If American badger is detected, the biologist shall passively relocate any individual out of the work area prior to construction if feasible. Potentially active and active dens that would be directly impacted by construction activities will be monitored for at least three consecutive nights using a wildlife-monitoring camera or tacking media at the entrance. If no photos or tracks of badgers are captured after three nights, the den will be excavated and backfilled by hand. In the event that passive relocation fails, the qualified biologist will consult with CDFW to explore other relocation options, which may include trapping.

BIO-6. Protect pallid bat.

A pre-construction clearance survey shall be conducted by a qualified biologist to ensure that no roosting pallid bats will be disturbed during the implementation of the Project. A pre-construction clearance survey shall be conducted no more than 14 days prior to the initiation of construction activities. During this survey, the qualified biologist shall inspect all potential roosting habitat in and immediately adjacent to the impact areas. If an active roost is found close enough to the construction area to be disturbed by these activities, the qualified biologist shall determine the extent of a construction-free buffer to be established around the roost. If work cannot proceed without disturbing the roosting bats, work may need to be halted or redirected to other areas until the roost is no longer in use.

- b) Have a substantial adverse effect on any riparian habitat or other sensitive natural community identified in local or regional plans, policies, regulations, or by the California Department of Fish and Game or U.S. Fish and Wildlife Service?

- c) Have a substantial adverse effect on federally protected wetlands as defined by Section 404 of the Clean Water Act (including, but not limited to, marsh, vernal pool, coastal, etc.) through direct removal, filling, hydrological interruption, or other means?

Less Than Significant Impact. According to the BRE, the proposed Project will not have a substantial adverse effect on any riparian habitat or other sensitive natural community identified in local or regional plans, policies, regulations, or by the CDFW or USFWS as no riparian habitat or other sensitive natural community is present in the survey area. The proposed Project will not have a substantial adverse effect on state or federally protected wetlands (including, but not limited to marsh, vernal pool, coastal, etc.) through direct removal, filling, hydrological interruption, or other means as no impacts to wetlands will occur. As such, there will be *less than significant impacts*.

Mitigation Measures: None are required.

- d) Interfere substantially with the movement of any native resident or migratory fish or wildlife species or with established native resident or migratory wildlife corridors, or impede the use of native wildlife nursery sites?

Less than Significant Impact with Mitigation. The Project has the potential to impede the use of nursery sites for native birds protected under the Migratory Bird Treaty Act (MBTA) and California Fish and Game Code (CFG). Migratory birds are expected to nest on and near the Project site. Construction disturbance during the breeding season could result in the incidental loss of fertile eggs or nestlings or otherwise lead to nest abandonment. Disturbance that causes nest abandonment or loss of reproductive effort can be considered take under the MBTA and CFG. Loss of fertile eggs or nesting birds, or any activities resulting in nest abandonment, could constitute a significant effect if the species is particularly rare in the region. Construction activities such as excavating, trenching, and grading that disturb a nesting bird in the Project site or immediately adjacent to the construction zone could constitute a significant effect. Mitigation measure BIO-7 (below) will be included in the conditions of approval to reduce the potential effect to a *less than significant* level.

Mitigation Measures:

BIO-7. Protect nesting birds.

1. To the extent practicable, construction shall be scheduled to avoid the nesting season, which extends from February through August.

2. If it is not possible to schedule construction between September and January, pre-construction surveys for nesting birds shall be conducted by a qualified biologist to ensure that no active nests will be disturbed during the implementation of the Project. A pre-construction survey shall be conducted no more than 14 days prior to the initiation of construction activities. During this survey, the qualified biologist shall inspect all potential nest substrates in and immediately adjacent to the impact areas. If an active nest is found close enough to the construction area to be disturbed by these activities, the qualified biologist shall determine the extent of a construction-free buffer to be established around the nest. If work cannot proceed without disturbing the nesting birds, work may need to be halted or redirected to other areas until nesting and fledging are completed or the nest has otherwise failed for non-construction related reasons.

- e) Conflict with any local policies or ordinances protecting biological resources, such as a tree preservation policy or ordinance?
- f) Conflict with the provisions of an adopted Habitat Conservation Plan, Natural Community Conservation Plan, or other approved local, regional, or state habitat conservation plan?

No Impact. According to the BRE, the proposed Project will not conflict with any local policies or ordinances protecting biological resources, such as a tree preservation policy or ordinance as no trees or biologically sensitive areas will be impacted. The development will also not conflict with the provisions of an adopted Habitat Conservation Plan, Natural Communities Conservation Plan, or other approved local, regional, or state habitat conservation plan as no such plan has been adopted. As such, there is *no impact*.

Mitigation Measures: None are required.

V. CULTURAL RESOURCES

Would the project:

	Potentially Significant Impact	Less than Significant With Mitigation Incorporation	Less than Significant Impact	No Impact
a. Cause a substantial adverse change in the significance of a historical resource as defined in §15064.5?	<input type="checkbox"/>	<input checked="" type="checkbox"/>	<input type="checkbox"/>	<input type="checkbox"/>
b. Cause a substantial adverse change in the significance of an archaeological resource pursuant to §15064.5?	<input type="checkbox"/>	<input checked="" type="checkbox"/>	<input type="checkbox"/>	<input type="checkbox"/>
c. Disturb any human remains, including those interred outside of formal cemeteries?	<input type="checkbox"/>	<input checked="" type="checkbox"/>	<input type="checkbox"/>	<input type="checkbox"/>

ENVIRONMENTAL SETTING

Archaeological resources are places where human activity has measurably altered the earth or left deposits of physical remains. Archaeological resources may be either prehistoric (before the introduction of writing in a particular area) or historic (after the introduction of writing). The majority of such places in this region are associated with either Native American or Euroamerican occupation of the area. The most frequently encountered prehistoric and early historic Native American archaeological sites are village settlements with residential areas and sometimes cemeteries; temporary camps where food and raw materials were collected; smaller, briefly occupied sites where tools were manufactured or repaired; and special-use areas like caves, rock shelters, and sites of rock art. Historic archaeological sites may include foundations or features such as privies, corrals, and trash dumps.

RESPONSES

- a) Cause a substantial adverse change in the significance of a historical resource as defined in §15064.5?
- b) Cause a substantial adverse change in the significance of an archaeological resource pursuant to §15064.5?
- c) Disturb any human remains, including those interred outside of formal cemeteries?

Less Than Significant Impact With Mitigation. A record search of the Project area and the environs within one half-mile was conducted at the Southern San Joaquin Archaeological Information Center. Information Center staff conducted the record search, RS# 23-482, on December 4, 2023 (see Appendix C). The record search revealed that there have been no previous cultural resource studies completed within the project area. There has been one cultural resource study completed within the half-mile radius: TU-00165.

There are no recorded resources within the Project area. There are 11 recorded resources within the half-mile radius: P-54-004907, 004945, 005017, 005018, 005019, 005020, 005021, 005022, 005023, 005024, & 005025. These resources consist of historic era canals, single family properties, multi-family properties, & 1-3 story buildings.

There are no recorded cultural resources within the project area or radius that are listed in the National Register of Historic Places, the California Register of Historical Resources, the California Points of Historical Interest, California Inventory of Historic Resources, for the California State Historic Landmarks.

Although no significant cultural or archaeological resources, paleontological resources or human remains have been identified in the project area, the possibility exists that such resources or remains may be discovered during Project site preparation, excavation and/or grading activities. Mitigation Measures CUL – 1 and CUL – 2 will be implemented to ensure that Project will result in *less than significant impacts with mitigation*.

Mitigation Measures:

CUL – 1

Should evidence of prehistoric archeological resources be discovered during construction, the contractor shall halt all work within 25 feet of the find and the resource shall be evaluated by a qualified archaeologist. If evidence of any archaeological, cultural, and/or historical deposits is found, hand excavation and/or mechanical excavation shall proceed to evaluate the deposits for determination of significance as defined by the CEQA guidelines. The archaeologist shall submit reports, to the satisfaction of the City of Dinuba, describing the testing program and subsequent results. These reports shall identify any program mitigation that the project proponent shall complete in order to mitigate archaeological impacts (including resource recovery and/or avoidance testing and analysis, removal, reburial, and curation of archaeological resources).

CUL – 2

In order to ensure that the proposed project does not impact buried human remains during construction, the project proponent shall be responsible for on-going monitoring of project construction. Prior to the issuance of any grading permit, the project proponent shall provide the City of Dinuba with documentation identifying construction personnel that will be responsible for on-site monitoring. If buried human remains are encountered during construction, further excavation or disturbance of the site or any nearby area reasonably suspected to overlie adjacent remains shall be halted until the Tulare County coroner is contacted and the coroner has made the determinations and notifications required pursuant to Health and Safety Code Section 7050.5. If the coroner determines that Health and Safety Code Section 7050.5(c) require that he give notice to the Native American Heritage Commission, then such notice shall be given within 24 hours, as required by Health and Safety Code Section 7050.5(c). In that event, the NAHC will conduct the notifications required by Public Resources Code Section 5097.98. Until the consultations described below have been completed, the landowner shall further ensure that the immediate vicinity, according to generally accepted cultural or archaeological standards or practices where Native American human remains are located, is not disturbed by further development activity until the landowner has discussed and conferred with the Most Likely Descendants on all reasonable options regarding the descendants' preferences and treatments, as prescribed by Public Resources Code Section 5097.98(b). The NAHC will mediate any disputes regarding treatment of remains in accordance with Public Resources Code Section 5097.94(k). The landowner shall be entitled to exercise rights established by Public Resources Code Section 5097.98(e) if any of the circumstances established by that provision become applicable.

VI. ENERGY

Would the project:

	Potentially Significant Impact	Less than Significant With Mitigation Incorporation	Less than Significant Impact	No Impact
--	--------------------------------	---	------------------------------	-----------

- a. Result in potentially significant environmental impact due to wasteful, inefficient, or unnecessary consumption of energy resources, during project construction or operation?
- b. Conflict with or obstruct a state or local plan for renewable energy or energy efficiency?

The following information was provided by an Air Quality, Health Risk Analysis, Greenhouse Gas, and Energy Technical Memorandum that was performed on behalf of the proposed project by Johnson, Johnson & Miller Air Quality Consulting Services, report date January 1, 2024. The report can be read in its entirety in Appendix A.

The energy requirements for the proposed Project were determined using the construction and operational estimates generated from the Air Quality Analysis (refer to Appendix A for related CalEEMod output files). The calculation worksheets for fuel consumption rates for off-road construction equipment and on-road vehicles are provided in Appendix A.

RESPONSES

a) Result in potentially significant environmental impact due to wasteful, inefficient, or unnecessary consumption of energy resources, during project construction or operation?

Less Than Significant Impact.

This impact addresses energy consumption from the short-term construction and long-term operations, discussed separately below.

Short-Term Energy Demand - Construction

Off-Road Equipment

Error! Reference source not found. provides estimates of the Project’s construction fuel consumption from off-road construction equipment for the entire Project, categorized by construction activity.²¹

Table 8
Construction Off-Road Fuel Consumption

Project Component	Construction Activity	Fuel Consumption (gallons)
Dinuba Empire Estates (On-site, Off-road Equipment Use)	Demolition	1,317
	Site Preparation	912
	Grading	4,516
	Paving	507
	Building Construction	14,610
	Architectural Coating	59
Construction Total		21,921
Source: Energy Consumption Calculations (Appendix A)		

As shown in **Error! Reference source not found.**, use of off-road equipment associated with construction of the proposed Project is estimated to consume approximately 21,921 gallons of diesel fuel over the entire construction duration. There are no unusual Project characteristics that would necessitate the use of construction equipment that would be less energy efficient than at comparable construction sites in the City of Dinuba, the larger Tulare County region, or other parts of California. Therefore, it is expected that construction fuel consumption associated with the proposed Project would not be any more inefficient, wasteful, or unnecessary than at other construction sites in the region.

On-Road Vehicles

On-road vehicles for construction workers, vendors, and haulers would require fuel for travel to and from the site during construction.

Table 6 provides an estimate of the total on-road vehicle fuel usage during construction. There are no unusual Project characteristics that would necessitate the use of construction equipment that would be less energy efficient than at comparable construction sites in other parts of Dinuba or the Tulare County region. Therefore, it is expected that construction fuel consumption associated with the

²¹ Dinuba Empire Estates – County of Tulare Project in Dinuba. Air Quality, Health Risk Analysis, Greenhouse Gas, and Energy Technical Memorandum. Johnson Johnson and Miller Air Quality Consulting Services. Prepared on January 1, 2024. Appendix A.

proposed Project would not be any more inefficient, wasteful, or unnecessary than at other construction sites in the region.

Table 6
Construction On-Road Fuel Consumption

	Project Component	Annual Fuel Consumption (gallons)
Dinuba Empire Estates (On-road Fuel Consumption)	Demolition	381
	Site Preparation	82
	Grading	1,570
	Paving	149
	Building Construction	5,176
	Architectural Coating	92
Total Construction On-Road Fuel Consumption		7,450
Source: Energy Consumption Calculations (Appendix A)		

Other Energy Consumption Anticipated During Project Construction

Other equipment could include construction lighting, field services (office trailers), and electrically driven equipment such as pumps and other tools. As construction activities would occur primarily during daylight hours, it is anticipated that the use of construction lighting would be minimal. Singlewide mobile office trailers, which are commonly used in construction staging areas, generally range in size from 160 square feet to 720 square feet. A typical 720-square-foot office trailer would consume approximately 29,553 kWh during the approximate 1.75-year construction phase (Appendix A).

Long-Term Operations

Building Energy Demand

As shown in Table 7 and Table 8, the proposed Project is estimated to demand 700,994 kilowatt-hours (KWhr) of electricity and 2,918,424 1,000-British Thermal Units (kBtu) of natural gas, respectively, on an annual basis.

Table 7

Long-Term Electricity Usage

Land Use	Total Electricity Demand (KWhr/year)
Single-family Housing	700,994
Other Asphalt Surfaces	0
Other Non-Asphalt Surfaces	0
Total Project Consumption	700,994
Source: Energy Consumption Calculations (Appendix A)	

Table 8
Long-Term Natural Gas Usage

Land Use	Total Natural Gas Demand (kBtu/year)
Single-family Housing	2,918,424
Other Asphalt Surfaces	0
Other Non-Asphalt Surfaces	0
Total Project Consumption	2,918,424
Source: Energy Consumption Calculations (Appendix A)	

Buildings and infrastructure constructed pursuant to the proposed Project would comply with the versions of CCR Titles 20 and 24, including California Green Building Standards (CALGreen), that are applicable at the time that building permits are issued. The proposed Project is estimated to demand 700,994 KWhr of electricity per year and 2,918,424 kBtu of natural gas per year. As the Project site is currently undeveloped with the exception of an existing residence located at the southwest portion of the Project site, this would represent an increase in demand for electricity and natural gas.

It would be expected that building energy consumption associated with the proposed Project would not be any more inefficient, wasteful, or unnecessary than for any other similar new single-family homes in the City of Dinuba or the larger Tulare County region. Current state regulatory requirements for new building construction contained in the 2022 CALGreen and Title 24 standards apply to both residential and non-residential buildings and would increase energy efficiency and reduce energy demand in comparison to most existing development, and therefore would reduce actual environmental effects associated with energy use from the proposed Project. Additionally, the CALGreen and Title 24 standards have increased efficiency standards through each update. The most recent 2022 standards became effective January 1, 2023 and will be updated in the next cycle that will become effective at the start of 2026. Therefore, while the proposed Project would result in increased electricity and natural gas demand, electricity and natural gas would be consumed more efficiently

than most existing development in Tulare County due to compliance with the latest building standards.

Based on the above information, the proposed Project would not result in the inefficient or wasteful consumption of electricity or natural gas, and impacts would be less than significant.

Transportation Energy Demand

Table 9 provides an estimate of the daily and annual fuel consumed by vehicles traveling to and from the proposed Project. These estimates were derived using the same assumptions used in the operational air quality analysis for the proposed Project.

Table 9
Long-Term Operational Vehicle Fuel Consumption

Vehicle Type	Percent of Vehicle Trips	Annual VMT	Average Fuel Economy (miles/gallon)	Total Daily Fuel Consumption (gallons)	Total Annual Fuel Consumption (gallons)
Passenger Cars (LDA)	52.44	1,019,105	30.75	90.8	33,141
Light Trucks (Pickups) and Medium Vehicles	43.60	847,311	22.61	102.7	37,472
Light-Heavy to Medium-Heavy Diesel Trucks	0.93	18,073	11.58	4.3	1,561
Heavy-heavy Trucks	2.12	41,200	6.05	18.6	6,805
Motorcycles	0.25	4,858	42.00	0.3	116
Other	0.66	12,826	7.29	4.8	1,759
Total	100	1,943,373	—	221.5	80,854

Notes:
 VMT = vehicle miles traveled
 Percent of Vehicle Trips and VMT provided by CalEEMod.
 "Other" consists of buses and motor homes.
 Source: Energy Consumption Calculations (Appendix A).

As shown above, annual vehicular fuel consumption is estimated to be 80,854 gallons of gasoline and diesel fuel combined. Using rates calculated for the earliest project operational year, daily consumption is estimated at approximately 222 gallons of fuel (see Appendix A).

The daily vehicular fuel consumption is estimated to be 222 gallons of combined gasoline and diesel fuel. Annual consumption is estimated at 80,854 gallons. In addition, the proposed Project would

constitute development within an established community and would not be opening a new geographical area for development.²² As such, the proposed Project would not result in unusually long trip lengths for future residents, visitors, or deliveries to the proposed residential development. The property is located near residential land uses, including adjacent rural single-family homes to the north, south, southwest, west and northwest of the Project site. The proposed Project would be well-positioned to accommodate an existing community and provide housing for planned growth. Vehicles accessing the site would be typical of vehicles accessing similar residential development uses in the City of Dinuba, Tulare County, and surrounding areas. For these reasons, vehicular fuel consumption associated with the proposed Project would not be any more inefficient, wasteful, or unnecessary than for any other similar land use activities in the region, and impacts would be *less than significant*.

Mitigation Measures: None are required.

b) Conflict with or obstruct a state or local plan for renewable energy or energy efficiency?

Less Than Significant Impact. The Project proposes the construction of new residential development that would be built in accordance with all applicable rules and regulations. Compliance with established and applicable regulations would ensure that the Project would not conflict with or obstruct any state or local plan for renewable energy or energy efficiency. Moreover, compliance with Title 24 standards would ensure that the proposed Project would not conflict with any energy conservation policies related to the proposed Project's building envelope, mechanical systems, and indoor and outdoor lighting. Notably, the applicable Title 24 standards require the project to include on-site renewable energy to serve the future Project residents. In addition, the proposed Project would constitute development within an established community. Specifically, the Project site is adjacent to built-up areas of the City of Dinuba and is accessible by existing paved roads. As such, the Project would not be opening a new geographical area for development such that it would not result in unusually long trip lengths for future Project residents or visitors. In addition, the proposed residential development is designed for increased walkability, facilitated by the proposed pedestrian connectivity throughout the Project site.

For the above reasons, the proposed Project would not conflict with or obstruct a state or local plan for renewable energy or energy efficiency, and impacts would be *less than significant*.

Mitigation Measures: None are required.

²² The Project site is located west of the City of Dinuba and is located directly adjacent to rural residences, a park, and catty-corner to a distribution center.

VII. GEOLOGY AND SOILS

Would the project:

	Potentially Significant Impact	Less than Significant With Mitigation Incorporation	Less than Significant Impact	No Impact
a. Expose people or structures to potential substantial adverse effects, including the risk of loss, injury, or death involving:				
i. Rupture of a known earthquake fault, as delineated on the most recent Alquist-Priolo Earthquake Fault Zoning Map issued by the State Geologist for the area or based on other substantial evidence of a known fault? Refer to Division of Mines and Geology Special Publication 42.	<input type="checkbox"/>	<input type="checkbox"/>	<input checked="" type="checkbox"/>	<input type="checkbox"/>
ii. Strong seismic ground shaking?	<input type="checkbox"/>	<input type="checkbox"/>	<input checked="" type="checkbox"/>	<input type="checkbox"/>
iii. Seismic-related ground failure, including liquefaction?	<input type="checkbox"/>	<input type="checkbox"/>	<input checked="" type="checkbox"/>	<input type="checkbox"/>
iv. Landslides?	<input type="checkbox"/>	<input type="checkbox"/>	<input checked="" type="checkbox"/>	<input type="checkbox"/>
b. Result in substantial soil erosion or the loss of topsoil?	<input type="checkbox"/>	<input type="checkbox"/>	<input checked="" type="checkbox"/>	<input type="checkbox"/>
c. Be located on a geologic unit or soil that is unstable, or that would become unstable as a result of the project, and potentially result in on- or off-site landslide, lateral spreading, subsidence, liquefaction or collapse?	<input type="checkbox"/>	<input type="checkbox"/>	<input type="checkbox"/>	<input checked="" type="checkbox"/>
d. Be located on expansive soil, as defined in Table 18-1-B of the most recently adopted Uniform Building Code	<input type="checkbox"/>	<input type="checkbox"/>	<input checked="" type="checkbox"/>	<input type="checkbox"/>

creating substantial risks to life or property?

- e. Have soils incapable of adequately supporting the use of septic tanks or alternative waste water disposal systems where sewers are not available for the disposal of waste water?
- f. Directly or indirectly destroy a unique paleontological resource or site or unique geologic feature?

ENVIRONMENTAL SETTING

Dinuba is located near the eastern edge of the Central Valley, which is a nearly flat northwest-southeast trending basin approximately 450 miles long and approximately 75 miles wide. The City of Dinuba is located on soils characterized by a thick section of sedimentary rock overlying a granitic basement layer. The hazards due to ground-shaking are considered low due to the relative distance of the City from seismic faults. The nearest faults are the Sierra Nevada Fault Zone (approximately 60 miles east), the San Joaquin Fault (approximately 75 miles northwest), and the San Andreas Fault (approximately 75 miles to the southwest). The City of Dinuba is located in a Seismic Zone II, as defined by the California Uniform Building Code.

RESPONSES

- a-i) Expose people or structures to potential substantial adverse effects, including the risk of loss, injury, or death involving rupture of a known earthquake fault, as delineated on the most recent Alquist-Priolo Earthquake Fault Zoning Map issued by the State Geologist for the area or based on other substantial evidence of a known fault? Refer to Division of Mines and Geology Special Publication 42.
- a-ii) Expose people or structures to potential substantial adverse effects, including the risk of loss, injury, or death involving strong seismic ground shaking?
- a-iii) Expose people or structures to potential substantial adverse effects, including the risk of loss, injury, or death involving seismic-related ground failure, including liquefaction?

a-iv) Expose people or structures to potential substantial adverse effects, including the risk of loss, injury, or death involving landslides?

Less Than Significant Impact. The proposed Project site is located on an approximately 18.6-acre site, west of Dinuba, outside the City limits but within the Sphere of Influence, northwest of Road 72 and West Sierra Way/Avenue 412. The proposed site is not located in an earthquake fault zone as delineated by the 1972 Alquist-Priolo Earthquake Fault Zoning Map Act.²³ The nearest known potentially active fault is the Sierra Nevada Fault Zone, located approximately 62 miles east of the site. No active faults have been mapped within the Project boundaries, so there is no potential for fault rupture. It is anticipated that the proposed Project site would be subject to some ground acceleration and ground shaking associated with seismic activity during its design life. The proposed Project site would be engineered and constructed in strict accordance with the earthquake resistant design requirements contained in the latest edition of the California Building Code (CBC) for Seismic Zone II, as well as Title 24 of the California Administrative Code, and therefore would avoid potential seismically induced hazards on planned structures.

The proposed Project site has a generally flat topography, which would preclude the likeliness of a landslide. The impact of seismic or landslide hazards on the Project would be *less than significant*.

Mitigation Measures: None are required.

b) Result in substantial soil erosion or the loss of topsoil?

Less Than Significant Impact. The Project Applicant intends to develop 75 single-family residential units on an approximately 18.6-acre site. The site is currently outside the western City limits of Dinuba, but within the Sphere of Influence. The development will also include access roads, parking, lighting and other associated improvements, including demolishing structures and undergrounding a canal. There is an existing home occupying a portion of the Project site, which will be demolished as part of the Project. An earthen agricultural drainage ditch (Horseman Ditch) spans the eastern boundary of the Project site, which will be piped and underground as part of the proposed development.

Construction activities associated with the Project involves ground preparation work for the new housing development and associated improvements. These activities could expose barren soils to sources of wind or water, resulting in the potential for erosion and sedimentation on and off the Project

²³ Earthquake Hazard Zones, California Department of Conservation. <https://maps.conservation.ca.gov/cgs/EOZApp/app/>. Accessed January 2024.

site. During construction, nuisance flow caused by minor rain could flow off-site. The City and/or contractor would be required to employ appropriate sediment and erosion control BMPs as part of a Stormwater Pollution Prevention Plan (SWPPP) that would be required in the California National Pollution Discharge Elimination System (NPDES). As such, any impacts would be considered *less than significant*.

Mitigation Measures: None are required.

- c) Be located on a geologic unit or soil that is unstable, or that would become unstable as a result of the project, and potentially result in on- or off-site landslide, lateral spreading, subsidence, liquefaction or collapse?
- d) Be located on expansive soil, as defined in Table 18-1-B of the most recently adopted Uniform Building Code creating substantial risks to life or property?

Less Than Significant Impact. See Section VI a. above. The site is not at significant risk from ground shaking, liquefaction, or landslide and is otherwise considered geologically stable. The City of Dinuba sits on top of a mix of different loam classifications; with the predominant soils in the proposed Project area Tujunga Loamy Sand and Flamen Loamy soil.²⁴ These soil types are characterized as moderately well drained to somewhat excessively drained, with negligible to low runoff. These soils also have low shrink/swell potential, which is generally not conducive to liquefaction. Additionally, liquefaction typically occurs when there is shallow groundwater, low-density non-plastic soils, and high-intensity ground motion.

The City of Dinuba is on relatively flat terrain which precludes the occurrence of landslides. Subsidence is typically related to over-extraction of groundwater from certain types of geologic formations where the water is partly responsible for supporting the ground surface. The City of Dinuba is not recognized by the U.S. Geological Service as being in an area of subsidence.²⁵ Additionally, ongoing potential impacts of groundwater depletion and subsidence are constantly being monitored by USGS through a system of extensometers positioned throughout the San Joaquin valley. Continuous measurements and aquifer-system response analysis enables appropriate governing of parameters set to mitigate subsidence impacts in the region. Impacts are considered *less than significant*.

²⁴ U.S. Department of Agriculture. Natural Resource Conservation Service. Web Soil Survey. <https://websoilsurvey.sc.egov.usda.gov/app/WebSoilSurvey.aspx>. Accessed January 2024.

²⁵ U.S. Geological Service. Areas of Land Subsidence in California. https://ca.water.usgs.gov/land_subsidence/california-subsidence-areas.html. Accessed January 2024.

Mitigation Measures: None are required.

e) Have soils incapable of adequately supporting the use of septic tanks or alternative waste water disposal systems where sewers are not available for the disposal of waste water?

No Impact. The proposed Project does not include the construction, replacement, or disturbance of septic tanks or alternative wastewater disposal systems. The Project will be required to tie into the existing City sewer system (See Utilities section for more details). Therefore, there is *no impact*.

Mitigation Measures: None are required.

f) Directly or indirectly destroy a unique paleontological resource or site or unique geologic feature?

Less Than Significant Impact. As identified in the cultural studies performed for the Project site (see Appendix C), there are no known paleontological resources on or near the site. Mitigation measures have been added that will protect unknown (buried) resources during construction, including paleontological resources. There are no unique geological features on site or in the area. Therefore, there is a *less than significant impact*.

Mitigation Measures: None are required.

VIII. GREENHOUSE GAS EMISSIONS

Would the project:

	Potentially Significant Impact	Less than Significant With Mitigation Incorporation	Less than Significant Impact	No Impact
a. Generate greenhouse gas emissions, either directly or indirectly, that may have a significant impact on the environment?	<input type="checkbox"/>	<input type="checkbox"/>	<input checked="" type="checkbox"/>	<input type="checkbox"/>
b. Conflict with an applicable plan, policy or regulation adopted for the purpose of reducing the emissions of greenhouse gases?	<input type="checkbox"/>	<input type="checkbox"/>	<input checked="" type="checkbox"/>	<input type="checkbox"/>

The following information was provided by an Air Quality, Health Risk Analysis, Greenhouse Gas, and Energy Technical Memorandum that was performed on behalf of the proposed project by Johnson, Johnson & Miller Air Quality Consulting Services, report date January 1, 2024. The report can be read in its entirety in Appendix A.

RESPONSES

a) Generate greenhouse gas emissions, either directly or indirectly, that may have a significant impact on the environment?

Less than Significant Impact. The City of Dinuba has not adopted a GHG reduction plan. In addition, the City has not completed the GHG inventory, benchmarking, or goal-setting process required to identify a reduction target and take advantage of the streamlining provisions contained in the CEQA Guidelines. The County of Tulare has adopted a Climate Action Plan; however, the County of Tulare’s Climate Action Plan is only applicable to unincorporated areas of Tulare County. Because the City of Dinuba would serve as the lead agency for approval of the project, the County of Tulare’s Climate Action Plan is not applicable to the Project. The SJVAPCD has adopted a Climate Action Plan, but it does not contain measures that are applicable to the Project. Therefore, the SJVAPCD Climate Action Plan cannot be applied to the Project. Since no other local or regional Climate Action Plan is in place, the Project is assessed for its consistency with CARB’s adopted Scoping Plans.

Consistency with CARB’s Adopted Scoping Plans

Consistency with AB 32 and CARB’s 2008 Scoping Plan

The State’s regulatory program implementing the 2008 Scoping Plan is now fully mature. All regulations envisioned in the Scoping Plan have been adopted, and the effectiveness of those regulations has been estimated by the agencies during the adoption process and then tracked to verify their effectiveness after implementation. The combined effect of this successful effort is that the State now projects that it will meet the 2020 target and achieve continued progress toward meeting post-2020 targets. Former Governor Brown, in the introduction to Executive Order B-30-15, stated “California is on track to meet or exceed the current target of reducing greenhouse gas emissions to 1990 levels by 2020, as established in the California Global Warming Solutions Act of 2006 (AB 32).”

Consistency with SB 32 and CARB’s 2017 Scoping Plan

The 2017 Climate Change Scoping Plan Update (2017 Scoping Plan) includes the strategy that the State intends to pursue to achieve the 2030 targets of Executive Order S-3-05 and SB 32. **Error! Reference source not found.** provides an analysis of the Project’s consistency with the 2017 Scoping Plan Update measures.

Table 10
Consistency with SB 32 Scoping Plan

Scoping Plan Measure	Project Consistency
SB 350 50% Renewable Mandate. Utilities subject to the legislation will be required to increase their renewable energy mix from 33% in 2020 to 50% in 2030. (The requirement is now 60% in 2030 per SB 100.)	Consistent: Project residents will purchase electricity from a PG&E, which is subject to the SB 350 Renewable Mandate and SB 100 Renewable Mandate. SB 100 revised the Renewable Portfolio Standard goals to achieve the 50 percent renewable resources target by December 31, 2026, and to achieve a 60 percent target by December 31, 2030. The specific provider for the City of Dinuba and the proposed project is Pacific Gas and Electric (PG&E). In February 2018, PG&E announced that it had reached California’s 2020 renewable energy goal 3 years ahead of schedule and delivers nearly 80 percent of its electricity from GHG-free resources. ¹
SB 350 Double Building Energy Efficiency by 2030. This is equivalent to a 20 percent reduction from 2014 building energy usage compared to current projected 2030 levels.	Not Applicable. This measure applies to existing buildings. New structures are required to comply with Title 24 Energy Efficiency Standards that are expected to increase in stringency over time. New buildings (new single-family homes) constructed as part of the proposed project would comply with the applicable Title 24 Energy Efficiency Standards in effect at the time building

Scoping Plan Measure	Project Consistency
	permits are received. The current Title 24 regulations are the 2022 Title 24 standards, which become effective January 1, 2023. The next update would become effective January 1, 2026.
Low Carbon Fuel Standard. This measure requires fuel providers to meet an 18 percent reduction in carbon content by 2030.	Consistent. This is a Statewide measure that cannot be implemented by a project applicant or lead agency. However, vehicles accessing the project site would be subject to the standards. Vehicles accessing the project site will use fuel containing lower carbon content as the fuel standard is implemented.
Mobile Source Strategy (Cleaner Technology and Fuels Scenario). Vehicle manufacturers will be required to meet existing regulations mandated by the LEV III and Heavy-Duty Vehicle programs. The strategy includes a goal of having 4.2 million ZEVs on the road by 2030 and increasing numbers of ZEV trucks and buses.	Consistent. The project consists of 75 single-family homes on approximately 18.59 gross acres. The project is residential in nature and would not engage in vehicle manufacturing; however, vehicles would access the project site during project operations. Future project residents and visitors can be expected to purchase increasing numbers of more fuel efficient and zero emission cars and trucks each year. The CALGreen Code requires electrical service in new development to be EV charger-ready. In addition, home deliveries will be made by increasing numbers of ZEV delivery trucks as the statewide fleet is expected to get cleaner over time.
Sustainable Freight Action Plan. The plan's target is to improve freight system efficiency 25 percent by increasing the value of goods and services produced from the freight sector, relative to the amount of carbon that it produces by 2030. This would be achieved by deploying over 100,000 freight vehicles and equipment capable of zero emission operation and maximize near-zero emission freight vehicles and equipment powered by renewable energy by 2030.	Not Applicable. The measure applies to owners and operators of trucks and freight operations. The project is residential in nature and would not be considered an industrial land use or a large freight operator. However, home deliveries are expected to be made by increasing numbers of ZEV delivery trucks as technology continues to improve accessibility to ZEV vehicles and as regulations are phased in over time.
Short-Lived Climate Pollutant (SLCP) Reduction Strategy. The strategy requires the reduction of SLCPs by 40 percent from 2013 levels by 2030 and the reduction of black carbon by 50 percent from 2013 levels by 2030.	Consistent. The project is not expected to include fireplaces. However, any hearths that would be installed will only include natural gas hearths that produce very little black carbon compared with wood burning fireplaces and heaters in line with the SJVAPCD's Guidance for Assessing and Mitigating Air Quality Impacts mitigation measures. ²
SB 375 Sustainable Communities Strategies. Requires Regional	Not Applicable. The project does not consist of a proposed regional transportation plan;

Scoping Plan Measure	Project Consistency
Transportation Plans to include a sustainable communities strategy for reduction of per capita vehicle miles traveled.	therefore, this measure is not applicable to the proposed project.
Post-2020 Cap-and-Trade Program. The Post 2020 Cap-and-Trade Program continues the existing program for another 10 years. The Cap-and-Trade Program applies to large industrial sources such as power plants, refineries, and cement manufacturers.	Consistent. The post-2020 Cap-and-Trade Program indirectly affects people who use the products and services produced by the regulated industrial sources when increased cost of products or services (such as electricity and fuel) are transferred to the consumers. The Cap-and-Trade Program covers the GHG emissions associated with electricity consumed in California, whether generated in-state or imported. Accordingly, GHG emissions associated with CEQA projects' electricity usage are covered by the Cap-and-Trade Program. The Cap-and-Trade Program also covers fuel suppliers (natural gas and propane fuel providers and transportation fuel providers) to address emissions from such fuels and from combustion of other fossil fuels not directly covered at large sources in the program's first compliance period.
Natural and Working Lands Action Plan. CARB is working in coordination with several other agencies at the federal, state, and local levels, stakeholders, and with the public, to develop measures as outlined in the Scoping Plan Update and the governor's Executive Order B-30-15 to reduce GHG emissions and to cultivate net carbon sequestration potential for California's natural and working land.	Not Applicable. The project is a residential development and will not be considered natural or working lands.
<p>Source: California Air Resources Board (CARB). 2017. The 2017 Climate Change Scoping Plan Update. January 20. Website: https://www.arb.ca.gov/cc/scopingplan/2030sp_pp_final.pdf. Accessed September 2023.</p> <p>¹ Pacific Gas and Electric (PG&E). 2018. PG&E Clean Energy Deliveries Already Meet Future Goals. Website: www.pge.com/en/about/newsroom/newsdetails/index.page?title=20180220_pge_clean_energy_deliveries_already_meet_future_goals. Accessed December 2023.</p> <p>² San Joaquin Valley Air Pollution Control District (SJVAPCD). 2015. Guidance for Assessing and Mitigating Air Quality Impacts. Website: https://www.valleyair.org/transportation/GAMAQI-2015/FINAL-DRAFT-GAMA. Accessed September 2023.</p>	

As described in **Error! Reference source not found.**, the proposed Project would be consistent with applicable 2017 Scoping Plan Update measures and would not obstruct the implementation of others that are not applicable. The State's regulatory program is able to target both new and existing development because the two most important strategies, motor vehicle fuel efficiency and emissions from electricity generation, obtain reductions equally from existing sources and new sources. This is

because all vehicle operators use cleaner low carbon fuels and buy vehicles subject to the fuel efficiency regulations and all building owners or operators purchase cleaner energy from the grid that is produced by increasing percentages of renewable fuels. This includes regulations on mobile sources such as the Pavley standards that apply to all vehicles purchased in California, the LCFS (Low Carbon Fuel Standard) that applies to all fuel sold in California, and the Renewable Portfolio Standard and Renewable Energy Standard under SB 100 that apply to utilities providing electricity to all California end users.

Moreover, the Scoping Plan strategy will achieve more than average reductions from energy and mobile source sectors that are the primary sources related to development projects and lower than average reductions from other sources such as agriculture. The proposed residential development Project's operational GHG emissions would principally be generated from electricity consumption and vehicle use, which are directly under the purview of the Scoping Plan strategy and have experienced reductions above the State average reduction. Considering the information summarized above, the proposed Project would be consistent with the State's AB 32 and SB 32 GHG reduction goals.

Consistency Regarding GHG Reduction Goals for 2050 under Executive Order S-3-05 and GHG Reduction Goals for 2045 under CARB's 2022 Scoping Plan

Regarding goals for 2050 under Executive Order S-3-05, at this time it is not possible to quantify the emissions savings from future regulatory measures, as they have not yet been developed; nevertheless, it can be anticipated that operation of the proposed Project would comply with whatever measures are enacted that State lawmakers decide would lead to an 80 percent reduction below 1990 levels by 2050. In its 2008 Scoping Plan, CARB acknowledged that the "measures needed to meet the 2050 are too far in the future to define in detail." In the First Scoping Plan Update; however, CARB generally described the type of activities required to achieve the 2050 target: "energy demand reduction through efficiency and activity changes; large scale electrification of on-road vehicles, buildings, and industrial machinery; decarbonizing electricity and fuel supplies; and rapid market penetration of efficiency and clean energy technologies that requires significant efforts to deploy and scale markets for the cleanest technologies immediately."

CARB recognized that AB 32 established an emissions reduction trajectory that will allow California to achieve the more stringent 2050 target: "These [greenhouse gas emission reduction] measures also put the State on a path to meet the long-term 2050 goal of reducing California's GHG emissions to 80 percent below 1990 levels. This trajectory is consistent with the reductions that are needed globally to stabilize the climate." In addition, CARB's First Update "lays the foundation for establishing a broad framework for continued emission reductions beyond 2020, on the path to 80 percent below 1990 levels

by 2050,” and many of the emission reduction strategies recommended by CARB would serve to reduce the proposed Project’s post-2020 emissions level to the extent applicable by law:

- **Energy Sector:** Continued improvements in California’s appliance and building energy efficiency programs and initiatives, such as the State’s zero net energy building goals, would serve to reduce the proposed Project’s emissions level. Additionally, further additions to California’s renewable resource portfolio would favorably influence the Project’s emissions level.
- **Transportation Sector:** Anticipated deployment of improved vehicle efficiency, zero emission technologies, lower carbon fuels, and improvement of existing transportation systems all will serve to reduce the Project’s emissions level.
- **Water Sector:** The Project’s emissions level will be reduced as a result of further desired enhancements to water conservation technologies.
- **Waste Management Sector:** Plans to further improve recycling, reuse and reduction of solid waste will beneficially reduce the Project’s emissions level.

For the reasons described above, the Project’s post-2020 emissions trajectory is expected to follow a declining trend, consistent with the 2030 and 2050 targets. The trajectory required to achieve the post-2020 targets is shown in Figure 4.

Figure 4: California’s Path to Achieving the 2050 Target²⁶

²⁶ Johnson, Johnson & Miller Air Quality Consulting Services. Air Quality, Health Risk Analysis, Greenhouse Gas, and Energy Technical Memorandum. January 1, 2024. Appendix A.

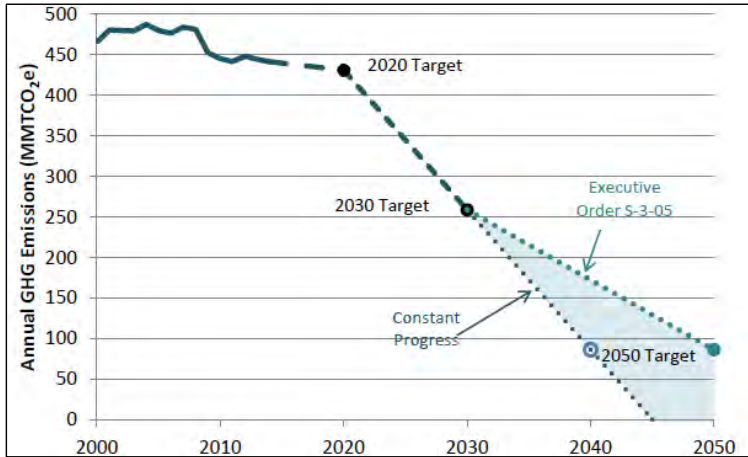

In his January 2015 inaugural address, former Governor Brown expressed a commitment to achieve “three ambitious goals” that he would like to see accomplished by 2030 to reduce the State’s GHG emissions:

- Increasing the State’s Renewable Portfolio Standard from 33 percent in 2020 to 50 percent in 2030;
- Cutting the petroleum use in cars and trucks in half; and
- Doubling the efficiency of existing buildings and making heating fuels cleaner.

These expressions of executive branch policy may be manifested in adopted legislative or regulatory action through the state agencies and departments responsible for achieving the State’s environmental policy objectives, particularly those relating to global climate change. Studies show that the State’s existing and proposed regulatory framework will allow the State to reduce its GHG emissions level to 40 percent below 1990 levels by 2030, and to 80 percent below 1990 levels by 2050. Even though these studies did not provide an exact regulatory and technological roadmap to achieve the 2030 and 2050 goals, they demonstrated that various combinations of policies could allow the statewide emissions level to remain very low through 2050, suggesting that the combination of new technologies and other regulations not analyzed in the studies could allow the State to meet the 2050 target.

Given the proportional contribution of mobile source-related GHG emissions to the State’s inventory, recent studies also show that relatively new trends—such as the increasing importance of web-based shopping, the emergence of different driving patterns, and the increasing effect of web-based

applications on transportation choices—are beginning to substantially influence transportation choices and the energy used by transportation modes. These factors have changed the direction of transportation trends in recent years and will require the creation of new models to effectively analyze future transportation patterns and the corresponding effect on GHG emissions. For the reasons described above, the proposed Project’s future emissions trajectory is expected to follow a declining trend, consistent with the 2030, 2045, and 2050 targets.

The 2017 Scoping Plan provides an intermediate target that is intended to achieve reasonable progress toward the 2050 target. In addition, the 2022 Scoping Plan outlines objectives, regulations, planning efforts, and investments in clean technologies and infrastructure that outlines how the State can achieve carbon-neutrality by 2045. The 2022 Scoping Plan strategies that are applicable to the Project include reducing fossil fuel use, energy demand, and vehicle miles traveled; maximizing recycling and diversion from landfills; and increasing water conservation. The Dinuba Empire Estates Project would be consistent with these goals through project design, which include complying with the latest requirements of the CALGreen Code and Building Energy Efficiency Standards. For instance, the latest building codes require all new single-family homes to be equipped with solar to provide on-site renewable energy. In addition, the Project would receive electricity from PG&E, which is required to reduce GHG emissions by increasing procurement from eligible renewable energy by set target years.

Furthermore, the Project would be consistent with goals to reduce VMT by constructing new homes near existing residential, commercial, and public uses. The Project would also to encourage alternative modes of transportation by providing infrastructure for future EV chargers (consistent with the applicable Building Code) and would provide pedestrian connectivity within the project site and to adjacent land uses. The Project would further align with goals in the 2022 Scoping Plan by incorporating a number of sustainable design features, including, but not limited, to installation of energy-efficient light fixtures, high-efficiency plumbing fixtures, EV parking spaces, and rooftop PV systems and solar panels (consistent with the requirements of Title 24).

Accordingly, taking into account the proposed Project’s design features and the progress being made by the State towards reducing emissions in key sectors such as transportation, industry, and electricity, the proposed Project would be consistent with State GHG Plans and would further the State’s goals of reducing GHG emissions 40 percent below 1990 levels by 2030, carbon neutral by 2045, and 80 percent below 1990 levels by 2050, and does not obstruct their attainment.

Conclusion

As described above, the proposed Project would be consistent with State GHG Plans (including CARB’s adopted 2017 and 2022 Scoping Plans) and would not obstruct the State’s ability to meet its

goals of reducing GHG emissions 40 percent below 1990 levels by 2030, carbon neutral by 2045, and 80 percent below 1990 levels by 2050. Therefore, the Project’s generation of GHG emissions would have a *less than significant* impact on the environment.

Mitigation Measures: None are required.

b) Conflict with an applicable plan, policy or regulation adopted for the purpose of reducing the emissions of greenhouse gases?

Less Than Significant Impact. As demonstrated in the analysis contained under Impact GHG-A above, the Project would not conflict with any applicable plan, policy, or regulation of an agency adopted to reduce the emissions of greenhouse gases. This impact would be *less than significant*.

Mitigation Measures: None are required.

IX. HAZARDS AND HAZARDOUS MATERIALS

Would the project:

	Potentially Significant Impact	Less than Significant With Mitigation Incorporation	Less than Significant Impact	No Impact
a. Create a significant hazard to the public or the environment through the routine transport, use, or disposal of hazardous materials?	<input type="checkbox"/>	<input type="checkbox"/>	<input checked="" type="checkbox"/>	<input type="checkbox"/>
b. Create a significant hazard to the public or the environment through reasonably foreseeable upset and accident conditions involving the release of hazardous materials into the environment?	<input type="checkbox"/>	<input type="checkbox"/>	<input checked="" type="checkbox"/>	<input type="checkbox"/>
c. Emit hazardous emissions or handle hazardous or acutely hazardous materials, substances, or waste within one-quarter mile of an existing or proposed school?	<input type="checkbox"/>	<input type="checkbox"/>	<input checked="" type="checkbox"/>	<input type="checkbox"/>
d. Be located on a site which is included on a list of hazardous materials sites compiled	<input type="checkbox"/>	<input type="checkbox"/>	<input type="checkbox"/>	<input checked="" type="checkbox"/>

pursuant to Government Code Section 65962.5 and, as a result, would it create a significant hazard to the public or the environment?

- e. For a project located within an airport land use plan or, where such a plan has not been adopted, within two miles of a public airport or public use airport, would the project result in a safety hazard for people residing or working in the project area?
- f. Impair implementation of or physically interfere with an adopted emergency response plan or emergency evacuation plan?
- g. Expose people or structures either directly or indirectly to a significant risk of loss, injury or death involving wildland fires?

ENVIRONMENTAL SETTING

The proposed Project site is located in the western portion of the City of Dinuba. The site currently supports a recently disced agricultural field, an agricultural ditch, and two rural residential structures and associated outbuildings.

RESPONSES

- a) Create a significant hazard to the public or the environment through the routine transport, use, or disposal of hazardous materials?
- b) Create a significant hazard to the public or the environment through reasonably foreseeable upset and accident conditions involving the release of hazardous materials into the environment?

Less Than Significant Impact. The Project Applicant intends to develop 75 single-family residential units on an approximately 18.6-acre site. The site is currently outside the western City limits of Dinuba,

but within the City’s adopted Sphere of Influence. The development will also include access roads, parking, lighting and other associated improvements. There is an existing home occupying a portion of the Project site, which will be demolished as part of the Project. An earthen agricultural drainage ditch (Horseman Ditch) spans the eastern boundary of the Project site, which will be piped and underground as part of the proposed development.

The Project site is bordered to the north by an orchard and rural residence, to the south by a paved road (W Sierra Way), an orchard, and an abandoned vineyard. to the east by a paved road (Road 72) and a community park; and to the west by a paved road (Road 70), a rural residence, and an orchard. A commercial distribution facility bordered the Project site to the northeast.

Proposed Project construction activities may involve the use and transport of hazardous materials. These materials may include fuels, oils, mechanical fluids, and other chemicals used during construction. Transportation, storage, use, and disposal of hazardous materials during construction activities would be required to comply with applicable federal, state, and local statutes and regulations. Compliance would ensure that human health and the environment are not exposed to hazardous materials. In addition, the Project would be required to comply with the National Pollutant Discharge Elimination System (NPDES) permit program through the submission and implementation of a Stormwater Pollution Prevention Plan during construction activities to prevent contaminated runoff from leaving the Project site. Therefore, no significant impacts would occur during construction activities.

The operational phase of the proposed Project would occur after construction is completed and residents move in to occupy the residential structures. The proposed Project will include land uses that are considered compatible with the surrounding uses. None of these land uses routinely transport, use, or dispose of hazardous materials, or present a reasonably foreseeable release of hazardous materials, with the exception of common residential grade hazardous materials such as household and commercial cleaners, paint, etc. The proposed Project would not create a significant hazard through the routine transport, use, or disposal of hazardous materials, nor would a significant hazard to the public or to the environment through the reasonably foreseeable upset and accidental conditions involving the likely release of hazardous materials into the environment occur. Therefore, the proposed Project will not create a significant hazard to the public or the environment and any impacts would be *less than significant*.

Mitigation Measures: None are required.

- c) Emit hazardous emissions or handle hazardous or acutely hazardous materials, substances, or waste within one-quarter mile of an existing or proposed school?

Less Than Significant Impact. There are no schools located within the 0.25-mile radius of the proposed Project site. The closest school is Wilson Elementary School, located approximately 1.25 miles to the southeast. As the proposed Project includes the development of single-family residences, it is not reasonably foreseeable that the proposed Project will cause a significant impact by emitting hazardous waste or bringing hazardous materials within one-quarter mile of an existing or proposed school. Residential land uses do not generate, store, or dispose of significant quantities of hazardous materials. Community commercial activities also do not normally involve dangerous activities that could expose persons onsite or in the surrounding areas to large quantities of hazardous materials. See also Responses *a.* and *b.* above regarding hazardous material handling. There would be a *less than significant impact*.

Mitigation Measures: None are required.

- d) Be located on a site which is included on a list of hazardous materials sites compiled pursuant to Government Code Section 65962.5 and, as a result, would it create a significant hazard to the public or the environment?

No Impact. A database search was conducted to identify recorded hazardous materials incidents in the Project area. The search included cleanup sites under Federal Superfund (National Priorities List), State Response, and other federal, state, and local agency lists. The proposed Project site is not located on a list of hazardous materials sites compiled pursuant to Government Code Section 65962.5 (Geotracker²⁷ and Envirostor²⁸ databases). There is *no impact*.

Mitigation Measures: None are required.

- e) For a project located within an airport land use plan or, where such a plan has not been adopted, within two miles of a public airport or public use airport, would the project result in a safety hazard for people residing or working in the project area?

²⁷ Geotracker Database, California State Water Resources Control Board.
<https://geotracker.waterboards.ca.gov/map/?CMD=runreport&myaddress=dinuba>. Accessed February 2024.

²⁸ EnviroStor Database, California Department of Toxic Control Substances.
<https://www.envirostor.dtsc.ca.gov/public/map/?myaddress=dinuba>. Accessed February 2024.

Less Than Significant Impact. There are no private or public airstrips in the Project vicinity. The Sequoia Field Airport is located approximately 8.5 miles to the southeast of the proposed Project site. Thus, any impacts are *less than significant*.

Mitigation Measures: None are required.

f) Impair implementation of or physically interfere with an adopted emergency response plan or emergency evacuation plan?

Less than Significant Impact. The Project has been designed for adequate emergency access and has been reviewed by the City. The internal roadways will be designed with sufficient clearances for emergency vehicles to access the entire site. Therefore, the Project will not impair or physically interfere with an adopted emergency response plan or emergency evacuation plan. Any impacts are *less than significant*.

Mitigation Measures: None are required.

g) Expose people or structures to a significant risk of loss, injury or death involving wildland fires, including where wildlands are adjacent to urbanized areas or where residences are intermixed with wildlands?

No Impact. There are no wildlands on or near the Project site. There is *no impact*.

Mitigation Measures: None are required.

X. HYDROLOGY AND WATER QUALITY

Would the project:

	Potentially Significant Impact	Less than Significant With Mitigation Incorporation	Less than Significant Impact	No Impact
a. Violate any water quality standards or waste discharge requirements or otherwise substantially degrade surface or ground water quality?	<input type="checkbox"/>	<input type="checkbox"/>	<input checked="" type="checkbox"/>	<input type="checkbox"/>
b. Substantially decrease groundwater supplies or interfere substantially with groundwater recharge such that the project may impede sustainable groundwater management of the basin?	<input type="checkbox"/>	<input type="checkbox"/>	<input checked="" type="checkbox"/>	<input type="checkbox"/>
c. Substantially alter the existing drainage pattern of the site or area, including through the alteration of the course of a stream or river or through the addition of impervious surfaces, in a manner which would:	<input type="checkbox"/>	<input type="checkbox"/>	<input checked="" type="checkbox"/>	<input type="checkbox"/>
i. Result in substantial erosion or siltation on- or off- site;	<input type="checkbox"/>	<input type="checkbox"/>	<input checked="" type="checkbox"/>	<input type="checkbox"/>
ii. substantially increase the rate or amount of surface runoff in a manner which would result in flooding on- or offsite;	<input type="checkbox"/>	<input type="checkbox"/>	<input checked="" type="checkbox"/>	<input type="checkbox"/>
iii. create or contribute runoff water which would exceed the capacity of existing or planned stormwater drainage systems or provide substantial additional sources of polluted runoff; or	<input type="checkbox"/>	<input type="checkbox"/>	<input checked="" type="checkbox"/>	<input type="checkbox"/>
iv. impede or redirect flood flows?	<input type="checkbox"/>	<input type="checkbox"/>	<input checked="" type="checkbox"/>	<input type="checkbox"/>

X. HYDROLOGY AND WATER QUALITY

Would the project:

	Potentially Significant Impact	Less than Significant With Mitigation Incorporation	Less than Significant Impact	No Impact
d. In flood hazard, tsunami, or seiche zones, risk release of pollutants due to project inundation?	<input type="checkbox"/>	<input type="checkbox"/>	<input checked="" type="checkbox"/>	<input type="checkbox"/>
e. Conflict with or obstruct implementation of a water quality control plan or sustainable groundwater management plan?	<input type="checkbox"/>	<input type="checkbox"/>	<input type="checkbox"/>	<input checked="" type="checkbox"/>

ENVIRONMENTAL SETTING

The City of Dinuba is located in the Tulare Lake hydrologic region, specifically within the Kings Sub-basin of the San Joaquin Valley groundwater basin.²⁹ The Kings Subbasin encompasses approximately 1,530 square miles within Fresno, Tulare and Kings counties. The Kings Subbasin is designated as a critically over-drafted high priority basin by the Department of Water Resources. The existence of overdraft in the Kings Subbasin is documented by historical decline in ground water levels and is confirmed by the historical water budgets presented by the Kings River East Groundwater Sustainability Agency and the Alta Irrigation District.³⁰ Dinuba has a groundwater depth of approximately 50 feet below the surface.

RESPONSES

- a) Violate any water quality standards or waste discharge requirements or otherwise substantially degrade surface or ground water quality?

²⁹ City of Dinuba, General Plan Update Draft Environmental Impact Report, December 2006. Page 3 – 74.

³⁰ City of Dinuba 2020 Urban Water Management Plan. December 2021. chrome-extension://efaidnbmnnnibpcajpcglclefindmkaj/https://www.dinuba.org/images/docs/forms/Urban-Water-Management-Plan.pdf. Accessed March 2024.

Less Than Significant Impact. The proposed Project site is currently vacant, with an existing residential dwelling in the southwestern portion, which will be removed as part of the Project.

Grading, excavation and loading activities associated with construction activities could temporarily increase runoff, erosion, and sedimentation. Construction activities also could result in soil compaction and wind erosion effects that could adversely affect soils and reduce the revegetation potential at construction sites and staging areas.

Three general sources of potential short-term construction-related stormwater pollution associated with the proposed project are: 1) the handling, storage, and disposal of construction materials containing pollutants; 2) the maintenance and operation of construction equipment; and 3) earth moving activities which, when not controlled, may generate soil erosion and transportation, via storm runoff or mechanical equipment. Generally, routine safety precautions for handling and storing construction materials may effectively mitigate the potential pollution of stormwater by these materials. These same types of common sense, “good housekeeping” procedures can be extended to non-hazardous stormwater pollutants such as sawdust and other solid wastes.

Poorly maintained vehicles and heavy equipment leaking fuel, oil, antifreeze, or other fluids on the construction site are also common sources of stormwater pollution and soil contamination. In addition, grading activities can greatly increase erosion processes. Two general strategies are recommended to prevent construction silt from entering local storm drains. First, erosion control procedures should be implemented for those areas that must be exposed. Secondly, the area should be secured to control offsite migration of pollutants. These Best Management Practices (BMPs) would be required in the Stormwater Pollution Prevention Plan (SWPPP) to be prepared prior to commencement of Project construction. When properly designed and implemented, these “good-housekeeping” practices are expected to reduce short-term construction-related impacts to less than significant.

In accordance with the National Pollution Discharge Elimination System (NPDES) Stormwater Program, the Project will be required to comply with existing regulatory requirements to prepare a SWPPP designed to control erosion and the loss of topsoil to the extent practicable using BMPs that the Regional Water Quality Control Board (RWQCB) has deemed effective in controlling erosion, sedimentation, runoff during construction activities. The specific controls are subject to the review and approval by the RWQCB and are an existing regulatory requirement.

The City of Dinuba will provide water to the Project site and the Project will be required to tie into the City’s existing water service infrastructure upon approval of Annexation. The Project will comply with all City ordinances and standards to assure proper grading and drainage. Compliance with all local, state, and federal regulations will prevent violation of water quality standards or waste discharge

requirements. The Project will be required to prepare a grading and drainage plan for review and approval by the City Engineer, prior to issuance of building permits. Therefore, any impacts will be *less than significant*.

Mitigation Measures: None are required.

- b) Substantially decrease groundwater supplies or interfere substantially with groundwater recharge such that the project may impede sustainable groundwater management of the basin?

Less Than Significant Impact. Site development will result in an increased demand for water. The City of Dinuba relies on groundwater as its sole water supply source. The City currently operates eight drinking water wells that are located throughout the PWS service area. In addition to the groundwater wells, the City maintains two elevated storage tanks with a capacity of 1.25 million gallons and the 2.0 MG Northeast Water Reservoir, a ground level tank and booster pump station.³¹

The City of Dinuba is part of the Kings River East Groundwater Sustainability Agency (KREGSA) which prepared a Groundwater Sustainability Plan (GSP) of which the City of Dinuba is a participant. The City adopted its latest Urban Water Management Plan (UWMP) in December 2021. The UWMP states that with implementation of the projects and management actions identified in the KREGSA GSP, the City's groundwater supplies are anticipated to be sustainable and available to meet the projected demands of its Public Water System service area.³²

The site has been planned for residential development in the General Plan and as such, has been accounted for in the City's infrastructure planning documents. Project demands for groundwater resources would not substantially deplete groundwater supplies and/or otherwise interfere with groundwater recharge efforts being implemented by the City of Dinuba. Future demand can be met with continued groundwater pumping and conservation measures. Additionally, compliance with existing State regulations will ensure that impacts to groundwater supply will be *less than significant*.

Mitigation Measures: None are required.

³¹ City of Dinuba 2020 Urban Water Management Plan, December 2021. Pg 6-1.

³² Ibid.

- c) Substantially alter the existing drainage pattern of the site or area, including through the alteration of the course of a stream or river or through the addition of impervious surfaces, in a manner which would:
- i. result in substantial erosion or siltation on- or offsite;
 - ii. substantially increase the rate or amount of surface runoff in a manner which would result in flooding on- or offsite;
 - iii. create or contribute runoff water which would exceed the capacity of existing or planned stormwater drainage systems or provide substantial additional sources of polluted runoff; or
 - iv. impede or redirect flood flows?

Less Than Significant Impact. The Project site is bordered to the north by an orchard and rural residence; to the south by a paved road (W Sierra Way), an orchard, and an abandoned vineyard; to the east by a paved road (Road 72) and a community park; and to the west by a paved road (Road 70), a rural residence, and an orchard. A commercial distribution facility bordered the Project site to the northeast. The existing irrigation canal, Horseman Ditch, on the eastern portion of the Project site will be piped and undergrounded.

The proposed Project will change drainage patterns of the site through the installation of impervious surfaces and structures (houses, driveways, streets, etc.) and will be required by the City to be graded to facilitate proper stormwater drainage into the stormwater basin included with the Project. Storm water during construction will be managed as part of the Storm Water Pollution Prevention Plan (SWPPP). A copy of the SWPPP will be retained on-site during construction.

The proposed Project site is located within Flood Zone "X" which is defined as "Area of Minimal Flood Hazard" as indicated by FEMA flood hazard map 06107C0320E, effective 6/15/2009. The proposed development will be built in accordance with the current City ordinances and California Building Code regarding construction in flood zones. The Project will be designed for adequate storm drainage. Accordingly, the chance of flooding (and therefore the release of pollutants due to flooding) at the site is remote. Impacts are *less than significant*.

Mitigation Measures: None are required.

- d) In flood hazard, tsunami or seiche zones, risk release of pollutants due to project inundation?

Less Than Significant Impact. As discussed in Impact X(c), the proposed Project site is located within a Special Flood Hazard Area, Flood Zone “X”. The Project includes development of adequate storm drainage. The proposed development will be required to prepare and submit a water quality control plan to be implemented during construction, as required by the National Pollutant Discharge Elimination System. This plan will be reviewed and approved by the City Engineer prior to the start of construction.

There are no inland water bodies that could be potentially susceptible to a seiche in the Project vicinity. This precludes the possibility of a seiche inundating the Project site. The Project site is more than 100 miles from the Pacific Ocean, a condition that precludes the possibility of inundation by tsunami. There are no steep slopes that would be susceptible to a mudflow in the Project vicinity, nor are there any volcanically active features that could produce a mudflow in the City of Dinuba. This precludes the possibility of a mudflow inundating the Project site. Any impacts are *less than significant*.

Mitigation Measures: None are required.

e) Conflict with or obstruct implementation of a water quality control plan or sustainable groundwater management plan?

No Impact. The Project will not conflict with any water quality control plans or sustainable groundwater management plan. However, as mentioned in Section c., all new development within the City of Dinuba Planning Area must conform to standards and plans contained in the Dinuba Stormwater Drainage Master Plan. By conforming to all standards and policies as outlined, there will be *no impacts* associated with the Project.

Mitigation Measures: None are required.

XI. LAND USE AND PLANNING

Would the project:

	Potentially Significant Impact	Less than Significant With Mitigation Incorporation	Less than Significant Impact	No Impact
a. Physically divide an established community?	<input type="checkbox"/>	<input type="checkbox"/>	<input checked="" type="checkbox"/>	<input type="checkbox"/>
b. Cause a significant environmental impact due to a conflict with any land use plan, policy, or regulation adopted for the purpose of avoiding or mitigating an environmental effect?	<input type="checkbox"/>	<input type="checkbox"/>	<input checked="" type="checkbox"/>	<input type="checkbox"/>

ENVIRONMENTAL SETTING

The proposed Project site is just outside the western City limit of Dinuba, within the City’s adopted Sphere of Influence. The City of Dinuba lies in the Central San Joaquin Valley region, in the northwestern portion of Tulare County. The City is approximately eight miles northeast of State Route (SR) 99 and 5.5 miles west of SR 63.

RESPONSES

a) Physically divide an established community?

b) Conflict with any applicable land use plan, policy, or regulation of an agency with jurisdiction over the project (including, but not limited to the General Plan, specific plan, local coastal program, or zoning ordinance) adopted for the purpose of avoiding or mitigating an environmental effect?

Less Than Significant Impact. The proposed Project includes development of 75 single-family residential units on an approximately 18.6-acre site. There is an existing home occupying a portion of the Project site, which will be demolished as part of the Project. The site is currently outside the western City limits of Dinuba, but within the Sphere of Influence. Entitlements needed to accommodate the proposed Project include Annexation, Zone Change, and a Tentative Subdivision Map.

The Project site is bordered to the north by an orchard and rural residence; to the south by a paved road (W Sierra Way), an orchard, and an abandoned vineyard; to the east by a paved road (Road 72)

and a community park; and to the west by a paved road (Road 70), a rural residence, and an orchard. A commercial distribution facility bordered the Project site to the northeast.

The Project would provide housing opportunities to the residents of Dinuba and improve access to existing surrounding areas. The proposed development has no characteristics that would physically divide the City of Dinuba. Any impacts will be *less than significant impact*.

Mitigation Measures: None are required.

XII. MINERAL RESOURCES

Would the project:

	Potentially Significant Impact	Less than Significant With Mitigation Incorporation	Less than Significant Impact	No Impact
a. Result in the loss of availability of a known mineral resource that would be of value to the region and the residents of the state?	<input type="checkbox"/>	<input type="checkbox"/>	<input type="checkbox"/>	<input checked="" type="checkbox"/>
b. Result in the loss of availability of a locally important mineral resource recovery site delineated on a local general plan, specific plan or other land use plan?	<input type="checkbox"/>	<input type="checkbox"/>	<input type="checkbox"/>	<input checked="" type="checkbox"/>

ENVIRONMENTAL SETTING

Tulare County commercially extracts important minerals such as sand, gravel, crushed rock and natural gas.³³ Other minerals have been mined in the county to a smaller extent, including tungsten, chromite, copper, gold, lead, manganese, silver, zinc, barite, feldspar, limestone and silica. Aggregate resources are considered the County's most valuable extractive mineral.

RESPONSES

- a) Result in the loss of availability of a known mineral resource that would be of value to the region and the residents of the state?
- b) Result in the loss of availability of a locally important mineral resource recovery site delineated on a local general plan, specific plan or other land use plan?

No Impact. There are no known mineral resources in the proposed Project area and the site is not included in a State classified mineral resource zones. No mineral resource locations are within the vicinity of the City of Dinuba.³⁴ Therefore, there is *no impact*.

Mitigation Measures: None are required.

³³ Tulare County General Plan Background Report, February 2010. Page 10-17.

³⁴ City of Dinuba General Plan Update Background Report, October 2006. Page 9-12.

XIII. NOISE

Would the project:

	Potentially Significant Impact	Less than Significant With Mitigation Incorporation	Less than Significant Impact	No Impact
a. Generation of a substantial temporary or permanent increase in ambient noise levels in the vicinity of the project in excess of standards established in the local general plan or noise ordinance, or applicable standards of other agencies?	<input type="checkbox"/>	<input type="checkbox"/>	<input checked="" type="checkbox"/>	<input type="checkbox"/>
b. Generation of excessive groundborne vibration or groundborne noise levels?	<input type="checkbox"/>	<input type="checkbox"/>	<input checked="" type="checkbox"/>	<input type="checkbox"/>
c. For a project located within the vicinity of a private airstrip or an airport land use plan or, where such a plan has not been adopted, within two miles of a public airport or public use airport, would the project expose people residing or working in the project area to excessive noise levels?	<input type="checkbox"/>	<input type="checkbox"/>	<input type="checkbox"/>	<input checked="" type="checkbox"/>

ENVIRONMENTAL SETTING

Noise is often described as unwanted sound. Although sound can be easily measured, the perception of noise and the physical response to sound complicate the analysis of its impact on people. The City of Dinuba is impacted by a multitude of noise sources. Principal noise sources include traffic on roadways, agricultural noise and industrial noise. Mobile sources of noise, especially cars and trucks, are the most common and significant sources of noise in most communities, and they are predominant sources of noise in the City. The Project site is located in an area with a mix of uses. The predominant noise sources in the Project area include traffic on local roadways, rural residential noise (lawn movers, audio equipment, voices, etc.), commercial activity noise, and potential noise from the nearby agricultural land uses.

RESPONSES

- a) Generation of a substantial temporary or permanent increase in ambient noise levels in the vicinity of the project in excess of standards established in the local general plan or noise ordinance, or applicable standards of other agencies?
- b) Generation of excessive groundborne vibration or groundborne noise levels?

Less Than Significant Impact.

Short-term (Construction) Noise Impacts

Proposed Project construction related activities will involve temporary noise sources. Typical construction related equipment include graders, trenchers, small tractors and excavators. During the proposed Project construction, noise from construction related activities will contribute to the noise environment in the immediate vicinity. Table 14 indicates the anticipated noise levels of the typical construction-related equipment (i.e., graders, trenchers, tractors) based on a distance of 50-feet between the equipment and the sensitive noise receptor.³⁵

Table 14
Typical Construction Noise Levels

Equipment	Typical Noise Level (dBA) 50 ft from Source
Air Compressor	80
Backhoe	80
Compactor	82
Concrete Mixer	85
Dozer	85
Generator	82
Grader	85
Jack Hammer	88
Loader	85
Paver	85
Truck	84

³⁵ The Noise and Vibration Impact Assessment Manual, Federal Transit Administration, U.S. Department of Transportation. September 2018. https://www.transit.dot.gov/sites/fta.dot.gov/files/docs/research-innovation/118131/transit-noise-and-vibration-impact-assessment-manual-fta-report-no-0123_0.pdf, Table 7-1. Accessed February 2024.

The distinction between short-term construction noise impacts and long-term operational noise impacts is a typical one in both CEQA documents and local noise ordinances, which generally recognize the reality that short-term noise from construction is inevitable and cannot be mitigated beyond a certain level. Thus, local agencies frequently tolerate short-term noise at levels that they would not accept for permanent noise sources. A more severe approach would be impractical and might preclude the kind of construction activities that are to be expected from time to time in urban environments. Most residents of urban areas recognize this reality and expect to hear construction activities on occasion.

Long-term (Operational) Noise Impacts

The primary source of on-going noise from the Project will be from vehicles traveling on internal access roads and from traffic traveling along W Sierra Way and Road 72. The Project will result in an increase in traffic on some roadways in the Project area. However, the relatively low number of new trips associated with the Project is not likely to increase the ambient noise levels by a significant amount. The area is active with vehicles, residential housing, commercial, and agricultural land uses, so the proposed Project will not introduce a new significant source of noise that isn’t already occurring in the area.

Vibration Levels

Typical outdoor sources of perceptible ground borne vibration are construction equipment, steel-wheeled trains, and traffic on rough roads. Construction vibrations can be transient, random, or continuous. Construction associated with the proposed Project includes construction of 75 single-family residences, demolition of existing rural residence, and undergrounding of the existing irrigation canal, Horseman Ditch. The site construction will also include internal access roads, street lighting, site landscaping and additional related improvements.

The approximate threshold of vibration perception is 65 VdB, while 85 VdB is the vibration acceptable only if there are an infrequent number of events per day. Table 15 describes the typical construction equipment vibration levels.³⁶

Table 15
Typical Construction Vibration Levels

Equipment	VdB at 25 ft
Small Bulldozer	58
Jackhammer	79

³⁶ Ibid.

Vibration from construction activities will be temporary and not exceed the Federal Transit Administration (FTA) threshold for the nearest rural residences which are located to the north, south, and west of the Project site.

Therefore, the impact is considered *less than significant*.

Mitigation Measures: None are required.

- c) For a project located within the vicinity of a private airstrip or an airport land use plan, or, where such a plan has not been adopted, within two miles of a public airport or public use airport, would the project expose people residing or working in the project area to excessive noise levels?

No Impact. The Project is not located within an airport land use plan, and the City of Dinuba does not contain any airport or airstrip. Therefore, there is *no impact*.

Mitigation Measures: None are required.

XIV. POPULATION AND HOUSING

Would the project:

	Potentially Significant Impact	Less than Significant With Mitigation Incorporation	Less than Significant Impact	No Impact
a. Induce substantial population growth in an area, either directly (for example, by proposing new homes and businesses) or indirectly (for example, through extension of roads or other infrastructure)?	<input type="checkbox"/>	<input type="checkbox"/>	<input checked="" type="checkbox"/>	<input type="checkbox"/>
b. Displace substantial numbers of existing housing, necessitating the construction of replacement housing elsewhere?	<input type="checkbox"/>	<input type="checkbox"/>	<input checked="" type="checkbox"/>	<input type="checkbox"/>

ENVIRONMENTAL SETTING

Dinuba’s population has exhibited major growth since 2000. The population in 2000 was 16,844³⁷, while the population as of January 2023 was 25,469.³⁸ This represents an approximate increase of 51.2%. Estimates for 2023 shows that the City has 7,170 housing units with an average of 3.58 people per household.³⁹

RESPONSES

- a) Induce substantial population growth in an area, either directly (for example, by proposing new homes and businesses) or indirectly (for example, through extension of roads or other infrastructure)?
- b) Displace substantial numbers of existing housing, necessitating the construction of replacement housing elsewhere?

³⁷ City of Dinuba General Plan Update Background Report, October 2006. Page 4-1.

³⁸ E-5 Population and Housing Estimates for Cities, Counties, and the State, 2020-2023. California Department of Finance, January 2024. <http://www.dof.ca.gov/Forecasting/Demographics/Estimates/E-5/> Accessed January 2024.

³⁹ Ibid.

Less Than Significant Impacts. There will be 75 new homes associated with the proposed Project and there is one rural residence currently on-site. The site would provide additional housing for approximately 269 people. This is a relatively small population and is not expected to affect any regional population, housing or employment projections anticipated by City documents.

The site is currently outside the western City limits of Dinuba, but within the Sphere of Influence. As such, the increase in population has been planned for. Entitlements needed to accommodate the proposed Project include Annexation, Zone Change, and a Tentative Subdivision Map. The City of Dinuba's primary industry is agriculture, but there is sufficient labor force in the area to support many other types of industries. The proposed Project will alleviate some overcrowding in the regional population by contributing reliable housing, and will additionally provide temporary construction jobs to the local workforce. In conclusion, the Project implementation will not displace substantial numbers of people and instead provide needed housing. Any impacts are considered *less than significant*.

Mitigation Measures: None are required.

XV. PUBLIC SERVICES

Would the project:

Potentially Significant Impact	Less than Significant With Mitigation Incorporation	Less than Significant Impact	No Impact
--------------------------------------	---	------------------------------------	--------------

- a. Would the project result in substantial adverse physical impacts associated with the provision of new or physically altered governmental facilities, need for new or physically altered governmental facilities, the construction of which could cause significant environmental impacts, in order to maintain acceptable service ratios, response times or other performance objectives for any of the public services:

Fire protection?	<input type="checkbox"/>	<input type="checkbox"/>	<input checked="" type="checkbox"/>	<input type="checkbox"/>
Police protection?	<input type="checkbox"/>	<input type="checkbox"/>	<input checked="" type="checkbox"/>	<input type="checkbox"/>
Schools?	<input type="checkbox"/>	<input type="checkbox"/>	<input checked="" type="checkbox"/>	<input type="checkbox"/>
Parks?	<input type="checkbox"/>	<input type="checkbox"/>	<input checked="" type="checkbox"/>	<input type="checkbox"/>
Other public facilities?	<input type="checkbox"/>	<input type="checkbox"/>	<input checked="" type="checkbox"/>	<input type="checkbox"/>

ENVIRONMENTAL SETTING

The Dinuba Fire Department is located at 496 East Tulare Street, Dinuba, approximately 1.4 miles east of the Project site. The Dinuba Fire Department offers a full range of services including fire/rescue, emergency medical treatment and transport, fire prevention, and hazardous materials first response.

Police protection services is provided by the Dinuba Police Department, which is approximately 1.1 miles east of the Project site at 680 South Alta Avenue, Dinuba. The Dinuba Police Department provides a full range of police services.

Educational services are provided by the Dinuba Unified School District (DUSD). Dinuba Unified School District operates eleven schools within the planning area; six elementary schools, one middle

school, one traditional high school, one continuing education school, one independent study school, and one adult education school.

RESPONSES

a) Would the project result in substantial adverse physical impacts associated with the provision of new or physically altered governmental facilities, need for new or physically altered governmental facilities, the construction of which could cause significant environmental impacts, in order to maintain acceptable service ratios, response times or other performance objectives for any of the public services:

Fire protection?

Less Than Significant Impact.

The proposed Project would be required to comply with all applicable fire and building safety codes (California Building Code and Uniform Fire Code) to ensure fire safety elements are incorporated into final Project design, including the providing designated fire lanes marked as such. Proposed interior streets will be required to provide appropriate widths and turning radii to safely accommodate emergency response and the transport of emergency/public safety vehicles. The proposed Project will also be designed to meet Fire Department requirements regarding water flow, water storage requirements, hydrant spacing, infrastructure sizing, and emergency access. As a result, appropriate fire safety considerations will be included as part of the final design of the Project. The proposed Project at full buildout will add to the number of “customers” served, however, the Fire Department has capacity for the additional service need. No additional fire equipment, personnel, or services are anticipated to be required by Project implementation. In addition, the Project applicant will be required to pay all associated impact fees related to public services. As such, any impacts are *less than significant*.

Police Protection?

Less Than Significant Impact. Implementation of the proposed Project would result in an increase in demand for police services; however, this increase would be minimal compared to the number of officers currently employed by the Dinuba Police Department and would not trigger the need for new or physically altered police facilities. No additional police personnel or equipment is anticipated. In addition, each home will be assessed a public safety impact fee by the City that is used to make capital improvements for the Police Department. The proposed site has been designated by the General Plan and zoned for residential purposes. Impacts are *less than significant*.

Schools?

Less Than Significant Impact. Since the proposed Project includes the addition of approximately 75 residential units, the number of students in the school district will increase. New development projects are required by state law to pay development impact fees to the school districts at the time of building permit issuance. These impact fees are used by the school districts to maintain existing and develop new facilities, as needed.

While development of the 75 residential units alone is not expected to require the alteration of existing or construction of new school facilities, the development will contribute to the cumulative need for increased school facilities. The timing of when new school facilities would be required or details about size and location cannot be known until such facilities are planned and proposed, and any attempt to analyze impacts to a potential future facility would be speculative. As the future new school facilities are further planned and developed, they would be subject to their own separate CEQA environmental review in order to identify and mitigate any potential environmental impacts. Therefore, the impact is *less than significant*.

Parks?

Less Than Significant Impact. The closest park to the proposed Project is the Centennial Park located immediately to the east of the site, across Road 72. The Project will be required to pay City Park facility impact fees to compensate for any service demand increase on existing parks within the Dinuba area. The Project applicant would be required to comply with the Municipal Code and Ordinances. Impacts are *less than significant*.

Other public facilities?

Less Than Significant Impact. The proposed Project is within the land use and growth projections identified in the City's General Plan and other infrastructure studies. The Project, therefore, would not result in increased demand for, or impacts on, other public facilities such as library services. Any impacts would be *less than significant*.

Mitigation Measures: None are required.

XVI. RECREATION

Would the project:

	Potentially Significant Impact	Less than Significant With Mitigation Incorporation	Less than Significant Impact	No Impact
a. Would the project increase the use of existing neighborhood and regional parks or other recreational facilities such that substantial physical deterioration of the facility would occur or be accelerated?	<input type="checkbox"/>	<input type="checkbox"/>	<input checked="" type="checkbox"/>	<input type="checkbox"/>
b. Does the project include recreational facilities or require the construction or expansion of recreational facilities which might have an adverse physical effect on the environment?	<input type="checkbox"/>	<input type="checkbox"/>	<input checked="" type="checkbox"/>	<input type="checkbox"/>

ENVIRONMENTAL SETTING

There are twelve parks within the City of Dinuba; Alice Park, Centennial Park, Felix Delgado Park, Gregory Park, K/C Vista Park, Nebraska Park, Pamela Park/Basin, Rose Ann Vuich Park, Roosevelt Park/Dinuba Community Center, Entertainment Plaza, Peachwood Park and Ponding Basin, and Rotary Park. These parks are managed by the City of Dinuba’s Parks and Community Services Department. This department also supervises and coordinates a wide variety of community programs and activities.

RESPONSES

- a) Would the project increase the use of existing neighborhood and regional parks or other recreational facilities such that substantial physical deterioration of the facility would occur or be accelerated?
- b) Does the project include recreational facilities or require the construction or expansion of recreational facilities which might have an adverse physical effect on the environment?

Less Than Significant Impact. The Project Applicant intends to develop 75 single-family residential units on an approximately 18.6-acre site. The site is currently outside the western City limits of Dinuba, but within the Sphere of Influence. To accommodate this Project, the City will need to approve an

Annexation, Zone Change, and Tentative Subdivision Map. However, the increase of approximately 269 persons resulting from the Project would have a relatively small impact on existing recreational facilities. In order to implement the goals and objectives of the City's General Plan, and to mitigate the impacts caused by future development in the City, park facilities must be constructed. The City Council has determined that a Park Facilities Fee is needed in order to finance these public facilities and to pay for each development's fair share of the construction and acquisition costs. The Project Applicant will be required to pay development impact fees as determined by the City of Park Facilities Fees. The Project will still be required to pay City park facility impact fees, as required. Therefore, impacts are considered *less than significant impacts*.

Mitigation Measures: None are required.

XVII. TRANSPORTATION/TRAFFIC

Would the project:

	Potentially Significant Impact	Less than Significant With Mitigation Incorporation	Less than Significant Impact	No Impact
a. Conflict with a program plan, ordinance or policy addressing the circulation system, including transit, roadway, bicycle and pedestrian facilities?	<input type="checkbox"/>	<input checked="" type="checkbox"/>	<input type="checkbox"/>	<input type="checkbox"/>
b. Would the project conflict or be inconsistent with CEQA Guidelines section 15064.3, subdivision (b)?	<input type="checkbox"/>	<input type="checkbox"/>	<input checked="" type="checkbox"/>	<input type="checkbox"/>
c. Substantially increase hazards due to a geometric design feature (e.g., sharp curves or dangerous intersections) or incompatible uses (e.g., farm equipment)?	<input type="checkbox"/>	<input type="checkbox"/>	<input checked="" type="checkbox"/>	<input type="checkbox"/>
d. Result in inadequate emergency access?	<input type="checkbox"/>	<input type="checkbox"/>	<input checked="" type="checkbox"/>	<input type="checkbox"/>

ENVIRONMENTAL SETTING

The proposed Project site is currently vacant, with an existing residential dwelling in the southwestern portion, which will be removed as part of the Project.

A Traffic Impact Analysis (TIA) report (Appendix D) and a Vehicle Miles Traveled (VMT) Analysis report (Appendix E) were prepared for the Project by JLB Traffic Engineering on March 2024 and is the basis of analysis for the following transportation analysis.

The purpose of the TIA is to evaluate the potential on-site and off-site traffic impacts, identify short-term and long-term roadway needs, determine potential roadway improvement measures and identify any critical traffic issues that should be addressed in the ongoing planning process. The TIA primarily focused on evaluating traffic conditions at study intersections that may potentially be impacted by the proposed Project. The Scope of Work was prepared via consultation with City of Dinuba, County of Tulare and Caltrans staff.

RESPONSES

a) Conflict with a program plan, ordinance or policy addressing the circulation system, including transit, roadway, bicycle and pedestrian facilities?

Less Significant Impact with Mitigation. The potential traffic impacts of the proposed Project were evaluated in accordance with the standards set forth by the Level of Service (LOS) policies of the City of Dinuba, County of Tulare and Caltrans.

While Level of Service is no longer the criteria of significance for traffic impacts in the state of California, the City of Dinuba continues to apply congestion-related conditions or requirements for land development projects through planning approval processes outside of CEQA Guidelines in order to continue the implementation of the City of Dinuba's *General Plan Policies Statement*.

Study Scenarios

- Existing Traffic Conditions
- Existing plus Project Traffic Conditions
- Near Term plus Project Traffic Conditions
- Cumulative Year 2046 plus Project Traffic Conditions

Project Access

Based on the Project Site Plan, access to and from the Project site will be from two (2) access points at buildout. The first access point will be located along the east side of Road 70 approximately 500 feet north of Avenue 412 and is proposed to be full access. The second access point will be located along the west side of Road 72 approximately 300 feet north of Avenue 412 and is also proposed to be full access.

Results of Existing Level of Service Analysis

At present, the intersection of Road 70 at Avenue 416 exceeds its LOS threshold during the PM peak period. It is recommended that the following improvements be considered for implementation to improve the LOS at this intersection.

- Road 70 / Avenue 416
 - Implement a raised median island along Avenue 416 to prevent left-turn and through movements from Road 70;
 - Modify the northbound left-through-right to a right-turn lane;

- o Modify the southbound left-through-right to a right turn lane; and

Existing plus Project Traffic Conditions

Project Trip Generation

The trip generation rates for the proposed Project were obtained from the 11th Edition of the Trip Generation Manual published by the Institute of Transportation Engineers (ITE). Table 16 presents the trip generation for the proposed Project with trip generation rates for 75 dwelling units of Single-Family Detached Housing (210). As requested by the City of Dinuba Consultant Engineer, the fitted curve was used to determine the project’s trip generation. As such, the rates contained in Table 16 are the equivalent rate when one uses the fitted curve and 75 single family dwelling units. At buildout, the proposed Project is estimated to generate approximately 774 daily trips, 57 AM peak hour trips and 76 PM peak hour trips.

Table 16
Project Trip Generation

Land Use (ITE Code)	Size	Unit	Daily		AM (7-9) Peak Hour					PM (4-6) Peak Hour						
			Rate	Total	Trip Rate	In	Out	In	Out	Total	Trip Rate	In	Out	In	Out	Total
Single-Family Detached Housing (210)	75	d.u.	10.32	774	0.76	26	74	15	42	57	1.01	63	37	48	28	76
Total Driveway Trips				774				15	42	57				48	28	76

Note: d.u. = Dwelling Units

The City of Dinuba *General Plan Policies Statement* does not have a dedicated bicycle plan. In the vicinity of the Project site, a Class II Bikeway exists along Monte Vista Way. Street standards for arterials within the City of Dinuba *General Plan Policies Statement* include parking and/or a bike lane in addition to other features. Therefore, it is recommended that the Project construct a Class II Bikeway along its frontage to Road 72.

Transit

Tulare County Regional Transportation Agency (TCRTA) is the transit operator in the City of Dinuba. At present there are four (4) TCRTA transit routes that operates in the direct vicinity of the proposed Project site. Details on the transit routes can be found in page 13 of Appendix D. Retention of the existing and expansion of future transit routes is dependent on transit ridership demand and available funding. TCRTA is considering expansion to its on-demand micro transit service in the areas of Dinuba and Woodlake at the time of the TIA report.

Results of Existing plus Project Level of Service Analysis

Under this scenario, the intersection of Road 70 at Avenue 416 is projected to exceed its LOS threshold during the PM peak period. It is recommended that the following improvements be considered for implementation to improve the LOS at this intersection.

- Road 70 / Avenue 416
 - Implement a raised median island along Avenue 416 to prevent left-turn and through movements from Road 70;
 - Modify the northbound left-through-right to a right-turn lane;
 - Modify the southbound left-through-right to a right turn lane; and
 - Furthermore, traffic will need to be rerouted due to the proposed limited access at the intersection of Road 70 at Avenue 416. Traffic volumes at the intersections of Road 72 at Avenue 416, Road 70 at Avenue 412 and Road 72 at Avenue 412 will be altered. As a result, those intersections will appear in the improved Synchro reports. No additional modifications as a result of this shift in traffic patterns were necessary.

Table 17 presents a summary of the Existing plus Project peak hour LOS at the study intersections. Table 18 presents a summary of the Existing plus Project peak hour LOS at the study segments.

Table 17
Existing plus Project Intersection LOS Results

ID	Intersection	Intersection Control	AM (7 - 9) Peak Hour		PM (4 - 6) Peak Hour	
			Average Delay (sec/veh)	LOS	Average Delay (sec/veh)	LOS
1	Road 70 / Avenue 416	Two-Way Stop	24.8	C	35.5	E
		Two-Way Stop (Improved)	10.6	B	12.2	B
2	Road 72 / Avenue 416	Traffic Signal	19.9	B	23.8	C
		Traffic Signal	20.2	C	24.2	C
3	Road 70 / Avenue 412	Two-Way Stop	10.2	B	9.9	A
		Two-Way Stop	10.4	B	10.3	B
4	Road 72 / Avenue 412	All-Way Stop	8.5	A	8.7	A
		All-Way Stop	8.6	A	8.7	A
5	Monte Vista Drive / Avenue 412	One-Way Stop	12.8	B	13.1	B

Note: LOS = Level of Service based on average delay on signalized intersections and All-Way STOP Controls
 LOS for two-way and one-way STOP controlled intersections are based on the worst approach/movement of the minor street.

Under this scenario, all study segments are projected to operate at an acceptable LOS.

Table 18
Existing plus Project Segment LOS Results

ID	Segment	Limits	Lanes	24-hour Volume	AM Peak Volume	AM LOS	PM Peak Volume	PM LOS
1	Avenue 412	Road 72 and Road 74	2	4,521	347	A	432	A
2	Avenue 412	Road 74 and Monte Vista Drive	2	7,439	568	B	721	C
3	Avenue 412	Monte Vista Drive and Samantha Way	2	6,172	473	B	616	B
4	Avenue 412	Samantha Way and Alta Avenue	2	6,006	452	B	553	B

Results of Near Term plus Project Level of Service Analysis

Under this scenario, the intersection of Road 70 at Avenue 416 is projected to exceed its LOS threshold during the PM peak period. It is recommended that the following improvements be considered for implementation to improve the LOS at this intersection.

- Road 70 / Avenue 416
 - Implement a raised median island along Avenue 416 to prevent left-turn and through movements from Road 70;
 - Modify the northbound left-through-right to a right-turn lane;
 - Modify the southbound left-through-right to a right turn lane; and
 - Furthermore, traffic will need to be rerouted due to the proposed limited access at in the intersection of Road 70 at Avenue 416. Traffic volumes at the intersections of Road 72 at Avenue 416, Road 70 at Avenue 412 and Road 72 at Avenue 412 will be altered. As a result, those intersections will appear in the improved Synchro reports. No additional modifications as a result of this shift in traffic patterns were necessary.

Results of Cumulative Year 2046 plus Project Level of Service Analysis

Under this scenario, the intersections of Road 70 at Avenue 416 and Road 72 at Avenue 416 are projected to exceed their LOS threshold during one or both peak periods. It is recommended that the following improvements be considered for implementation to improve the LOS at these intersections.

- Road 70 / Avenue 416
 - Implement a raised median island along Avenue 416 to prevent left-turn and through movements from Road 70;

Commented [KS1]: Is this the same as the immediate previous analysis?

Commented [EB2R1]: Nope- the immediate previous was existing plus project. They analyzed 4 scenarios- existing, existing plus project, near term plus project and year 2046 plus project.

- Modify the northbound left-through-right to a right-turn lane;
- Modify the southbound left-through-right to a right turn lane; and
- Furthermore, traffic will need to be rerouted due to the proposed limited access at the intersection of Road 70 at Avenue 416. Traffic volumes at the intersections of Road 72 at Avenue 416, Road 70 at Avenue 412 and Road 72 at Avenue 412 will be altered. As a result, those intersections will appear in the improved Synchro reports. No additional modifications as a result of this shift in traffic patterns were necessary.

- Road 72 / Avenue 416

- Add a northbound right-turn lane;
- Modify the northbound through-right lane to a through lane; and
- Modify the traffic signal to accommodate the added lanes.

Project's Pro-Rata Fair Share of Future Transportation Improvements

The Project's fair share percentage impact to the study intersection that currently operates below its LOS threshold, and which is not covered by an existing impact fee program, is provided in Table 19. The Project's fair share percentage impacts were calculated using the Caltrans pro-rata fair share formula. The Project's pro-rata fair shares were calculated utilizing the Existing, Project Only Trips and Cumulative Year 2046 plus Project volumes. Since the critical peak period for the study facilities was determined to be during the PM peak period, the PM peak traffic volumes are utilized to determine the Project's pro-rata fair share.

It is recommended that the Project contribute its equitable fair share as listed in Table 19 for the improvements necessary to return the intersection to an acceptable LOS. However, fair share contributions should only be made for those facilities or portion thereof not funded by the responsible agencies roadway impact fee program(s) or grant funding, as appropriate. For those improvements not presently covered by local and regional roadway impact fee programs or grant funding, it is recommended that the Project contribute its equitable fair share. Payment of the Project's equitable fair share in addition to the local and regional impact fee programs would satisfy the Project's traffic cumulative traffic impacts.

Commented [KS3]: What does "at in" mean?

Commented [EB4R3]: Should just be 'at

Table 19
Project's Fair Share of Future Roadway Improvements

ID	Intersection	Existing Traffic Volumes (PM Peak)	Cumulative Year 2046 Traffic Volumes (PM Peak)	Project Only Trips (PM Peak)	Project Fair Share (%)
1	Road 70 / Avenue 416	1,666	2,132	18	3.86
2	Road 72 / Avenue 416	1,958	2,903	35	3.70

Note: Project Fair Share = ((Project Only Trips) / (Cumulative Year 2046 plus Project Traffic Volumes – Existing Traffic Volumes)) X 100

As such, potential impacts will be *less than significant with mitigation incorporation*.

Mitigation Measure:

TRA-1

The Applicant shall pay the City of Dinuba for their fair share portion of the intersection improvements described in Table 19, in order to maintain or improve the operational level of service of the street system in the Project vicinity prior to issuance of building permits.

b) Would the project conflict or be inconsistent with CEQA Guidelines section 15064.3, subdivision (b)?

Less Than Significant Impact. The City of Dinuba has not yet adopted its own official VMT guidelines but uses the County of Tulare’s *SB 743 Guidelines*, referred to in this document as the County of Tulare’s VMT Guidelines. The County of Tulare’s VMT Guidelines were published on June 8, 2020 and are consistent with the requirements of CEQA Guidelines Sections 15064.3 and 15064.7. The December 2018 Technical Advisory on Evaluating Transportation Impacts in CEQA (Technical Advisory) published by the Governor’s Office of Planning and Research (OPR), was utilized as a reference and guidance document in the preparation of the County of Tulare’s VMT Guidelines.

VMT Output

The Traffic Analysis Zone (TAZ) in which the Project is located was determined to be TAZ 2777. Table 20 displays the VMT per capita for the TAZ in which the Project is located as well as the VMT per capita for the Project. The data for TAZ 2777 is stated in the County of Tulare VMT Guidelines while the Project VMT was output from the Tulare County Association of Governments (TCAG) regional model. As can be seen in Table 20, the Project VMT per capita is lower than the VMT per capita in the TAZ in which the Project is located.

Commented [EB5]: Karl, does the City have an impact fee program/grant program the applicant will pay into to take care of this mitigation or will they just pay the City prior to issuance of building permits?

Commented [KS6R5]: I've asked the City Engineer.

Table 20
VMT Output

VMT Measurement	TAZ 2777 VMT Results	Project (TAZ 193) VMT Results	Significant VMT Impact?
VMT per Capita	10.70	8.5	No

The TAZ in which the Project is located, TAZ 2777, has a VMT per capita of 10.7. TCAG analyzed the Project and output a VMT per capita of 8.5. As the Project has a VMT per capita that is less than the VMT per capita of the TAZ in which it is located, the Project was determined to have *less than significant* VMT impacts.

Mitigation Measures: None are required.

c) Substantially increase hazards due to a geometric design feature (e.g., sharp curves or dangerous intersections) or incompatible uses (e.g., farm equipment)?

Less Than Significant Impact. The proposed Project has been designed for ease of access, adequate circulation/movement, and is typical of residential developments in the City of Dinuba. On-site circulation patterns do not involve high speeds, sharp curves or dangerous intersections. Although there will be an increase in the volume of vehicles accessing the site and surrounding areas, the proposed Project will not present a substantial increase in hazards. Any impacts are considered *less than significant*.

Mitigation Measures: None are required.

d) Result in inadequate emergency access?

Less Than Significant Impact. The proposed Project does not involve a change to any emergency response plan. As currently planned, access to the proposed residential development would be provided along W Sierra Way and Road 72. The site will remain accessible to emergency vehicles of all sizes. As such, potential impacts are *less than significant*.

Mitigation Measures: None are required.

XVIII. TRIBAL CULTURAL RESOURCES

Would the project:

Potentially Significant Impact	Less than Significant With Mitigation Incorporation	Less than Significant Impact	No Impact
--------------------------------	---	------------------------------	-----------

a. Cause a substantial adverse change in the significance of a tribal cultural resource, defined in Public Resources Code section 21074 as either a site, feature, place, cultural landscape that is geographically defined in terms of the size and scope of the landscape, sacred place, or object with cultural value to a California Native American tribe, and that is:

i. Listed or eligible for listing in the California Register of Historical Resources, or in a local register of historical resources as defined in Public Resources Code section 5020.1(k), or

<input type="checkbox"/>	<input type="checkbox"/>	<input checked="" type="checkbox"/>	<input type="checkbox"/>
--------------------------	--------------------------	-------------------------------------	--------------------------

ii. A resource determined by the lead agency, in its discretion and supported by substantial evidence, to be significant pursuant to criteria set forth in subdivision (c) of Public Resources Code section 5024.1. In applying the criteria set forth in subdivision (c) of the Public Resources Code section 5024.1, the lead agency shall consider the significance of the resource to a California Native American tribe.

<input type="checkbox"/>	<input type="checkbox"/>	<input checked="" type="checkbox"/>	<input type="checkbox"/>
--------------------------	--------------------------	-------------------------------------	--------------------------

RESPONSES

a) Would the project cause a substantial adverse change in the significance of a tribal cultural resource, defined in Public Resources Code section 21074 as either a site, feature, place, cultural landscape that is geographically defined in terms of the size and scope of the landscape, sacred place, or object with cultural value to a California Native American tribe, and that is:

i) Listed or eligible for listing in the California Register of Historical Resources, or in a local register of historical resources as defined in Public Resources Code section 5020.1(k), or

ii) A resource determined by the lead agency, in its discretion and supported by substantial evidence, to be significant pursuant to criteria set forth in subdivision (c) of Public Resources Code Section 5024.1. In applying the criteria set forth in subdivision (c) of Public Resource Code Section 5024.1, the lead agency shall consider the significance of the resource to a California Native American tribe.

Less Than Significant Impact. In accordance with Assembly Bill (AB) 52 and Senate Bill (SB) 18, potentially affected Tribes were formally notified of this Project and were given the opportunity to request consultation on the Project. The City contacted the Native American Heritage Commission, requesting a contact list of applicable Native American Tribes, which was provided to the City. The City provided letters to the listed Tribes on November 22, 2023, notifying them of the Project and requesting consultation, if desired. The City did not receive any responses from the tribes contacted. Therefore, there is a *less than significant impact*.

Mitigation Measures: None are required.

Commented [KS7]: Correct date?

Commented [EB8R7]: Confirmed yes.

XIX. UTILITIES AND SERVICE SYSTEMS

Would the project:

	Potentially Significant Impact	Less than Significant With Mitigation Incorporation	Less than Significant Impact	No Impact
a. Require or result in the relocation or construction of new or expanded water, wastewater treatment or storm water drainage, electric power, natural gas, or telecommunications facilities, the construction or relocation of which could cause significant environmental effects?	<input type="checkbox"/>	<input type="checkbox"/>	<input checked="" type="checkbox"/>	<input type="checkbox"/>
b. Have sufficient water supplies available to serve the project and reasonably foreseeable future development during normal, dry and multiple dry years?	<input type="checkbox"/>	<input type="checkbox"/>	<input checked="" type="checkbox"/>	<input type="checkbox"/>
c. Result in a determination by the wastewater treatment provider which serves or may serve the project that it has adequate capacity to serve the project's projected demand in addition to the provider's existing commitments?	<input type="checkbox"/>	<input type="checkbox"/>	<input checked="" type="checkbox"/>	<input type="checkbox"/>
d. Generate solid waste in excess of State or local standards, or in excess of the capacity of local infrastructure, or otherwise impair the attainment of solid waste reduction goals?	<input type="checkbox"/>	<input type="checkbox"/>	<input checked="" type="checkbox"/>	<input type="checkbox"/>
e. Comply with federal, state, and local management and reduction statutes and regulations related to solid waste?	<input type="checkbox"/>	<input type="checkbox"/>	<input checked="" type="checkbox"/>	<input type="checkbox"/>

ENVIRONMENTAL SETTING

The proposed Project will be required to connect to water, sewer, stormwater and wastewater services provided by the City of Dinuba and may be subject to water use fees and/or development fees to be provided such service. In addition, the Project will require solid waste disposal services.

RESPONSES

- a) Require or result in the relocation or construction of new or expanded water, wastewater treatment or storm water drainage, electric power, natural gas, or telecommunications facilities, the construction or relocation of which could cause significant environmental effects?

Less than Significant Impact. The Project site is located within the service territory of the City of Dinuba and is currently designated for urban development in the City of Dinuba General Plan. Operational discharge flows treated at the City's wastewater treatment facility would be required to comply with applicable water discharge requirements issued by the Central Valley Regional Water Quality Control Board (RWQCB). Compliance with conditions or permit requirements established by the City as well as water discharge requirements outlined by the Central Valley RWQCB would ensure that wastewater discharges coming from the proposed Project site and treated by the WWTF system would not exceed applicable Central Valley RWQCB wastewater treatment requirements.

As discussed in Section X, Hydrology and Water Quality, with an increase in the area of impervious surfaces on the Project site, an increase in the amount of storm water runoff is anticipated. The site will be designed so that storm water is collected and deposited in the City's existing storm drain system. The storm water collection system design will be subject to review and approval by the City Public Works Department. Storm water during construction will be managed as part of the Storm Water Pollution Prevention Plan (SWPPP). A copy of the SWPPP is retained on-site during construction. Thus, the proposed Project would have a *less than significant impact*.

Mitigation Measures: None are required.

- b) Have sufficient water supplies available to serve the project and reasonably foreseeable future development during normal, dry and multiple dry years?

Less Than Significant Impact. Water service would be provided to the Project by the City of Dinuba. The City of Dinuba relies on groundwater as its sole water supply source. The system has a capacity of approximately 11 million gallons per day (7,600 GPM), and average daily demand is 4.2 million gallons

per day (or 2,900 GPM).⁴⁰ According to the City’s 2020 Urban Water Management Plan, the City currently operates eight drinking water wells that are located throughout the PWS service area. In addition to the groundwater wells, the City maintains two elevated storage tanks with a capacity of 1.25 million gallons and the 2.0 MG Northeast Water Reservoir, a ground level tank and booster pump station in the northeast section of the City.⁴¹ The City is a member of the Kings River East Groundwater Sustainability Agency (KREGSA). The City’s main water supply comes from eight active underground water wells distributed throughout the City. The water is treated and delivered to the community by the City of Dinuba water system. The most recent KREGSA GSP Annual Report indicates that groundwater levels at Representative Monitoring Sites near the City are above their designated Minimum Thresholds and on track to meet the forecast groundwater level projections and Interim Milestones established for these wells.⁴²

The City anticipates that its sources of supplies will be available to meet demands on a consistent basis for all year types throughout the planning horizon of the UWMP, as the site is within the adopted Sphere of Influence and has been included in the City’s infrastructure planning documentation. The proposed development will be required to follow the City’s General Plan and Zoning Ordinances which include land use goals, policies, and implementation measures for developments regarding water use. The Project developer will also be required to pay the City of Dinuba’s water system impact fees. Funds accrued under this fee are used to make capital improvements to the City’s water system, including conservation improvements. Impacts are *less than significant impact*.

Mitigation Measures: None are required.

c) Result in a determination by the wastewater treatment provider which serves or may serve the project that it has adequate capacity to serve the project’s projected demand in addition to the provider’s existing commitments?

Less Than Significant Impact. The proposed Project will result in wastewater from residential units that will be discharged into the City’s existing wastewater treatment system. The wastewater will be typical of other residential developments consisting of bathrooms, kitchen drains, and other similar features. The Project will not discharge any unusual or atypical wastewater that would violate the City’s waste discharge requirements. Therefore, assuming compliance with applicable standards and

⁴⁰ City of Dinuba 2015-2023 Housing Element. Pg 6-9. Accessed January 2024.

⁴¹ City of Dinuba 2020 Urban Water Management Plan. Pg 6-1. Accessed January 2024.

⁴² Ibid. Pg 1-3.

payment of required impact fees and connection charges, the Project would not result in a significant impact related to construction or expansions of existing wastewater treatment facilities. The impact of the Project on wastewater treatment is *less than significant*.

Mitigation Measures: None are required.

d) Generate solid waste in excess of State or local standards, or in excess of the capacity of local infrastructure, or otherwise impair the attainment of solid waste reduction goals?

e) Comply with federal, state, and local statutes and regulations related to solid waste?

Less Than Significant Impact. The City of Dinuba, through a private contractor, provides weekly curbside solid waste collection services to all households, businesses, and industries within City limits. Solid waste is taken to the Visalia Landfill, which is operated by Tulare County.⁴³ Furthermore, the proposed Project would be required to comply with all standards related to solid waste diversion, reduction, and recycling during Project construction and operation. The Project is not expected to generate an excess of solid waste beyond what is considered typical of residential land uses. The proposed Project will comply with all federal, state and local statutes and regulations related to solid waste. As such, any impacts would be *less than significant*.

Mitigation Measures: None are required.

⁴³ Solid Waste, Tulare County. <https://tularecounty.ca.gov/solidWaste/landfills/locations-fees/visalia-landfill/>. Accessed February 2024.

XX. WILDFIRE

If located in or near state responsibility areas or lands classified as very high fire hazard severity zones, would the project:

	Potentially Significant Impact	Less than Significant With Mitigation Incorporation	Less than Significant Impact	No Impact
a. Substantially impair an adopted emergency response plan or emergency evacuation plan?	<input type="checkbox"/>	<input type="checkbox"/>	<input checked="" type="checkbox"/>	<input type="checkbox"/>
b. Due to slope, prevailing winds, and other factors, exacerbate wildfire risks, and thereby expose project occupants to, pollutant concentrations from a wildfire or the uncontrolled spread of a wildfire?	<input type="checkbox"/>	<input type="checkbox"/>	<input checked="" type="checkbox"/>	<input type="checkbox"/>
c. Require the installation or maintenance of associated infrastructure (such as roads, fuel breaks, emergency water sources, power lines or other utilities) that may exacerbate fire risk or that may result in temporary or ongoing impacts to the environment?	<input type="checkbox"/>	<input type="checkbox"/>	<input checked="" type="checkbox"/>	<input type="checkbox"/>
d. Expose people or structures to significant risks, including downslope or downstream flooding or landslides, as a result of runoff, post-fire slope instability, or drainage changes?	<input type="checkbox"/>	<input type="checkbox"/>	<input checked="" type="checkbox"/>	<input type="checkbox"/>

ENVIRONMENTAL SETTING

The City of Dinuba’s planning area is composed of urbanized portions of land and the surrounding agricultural fields. The Project site has ensured fire protection by the Dinuba Fire Department, located at 496 East Tulare Street approximately 1.4 miles east of the site. Given the location of the nearest fire station, response time is expected to be extremely quick in the rare event of a fire event.

The proposed Project site’s elevation is approximately 320 feet above sea level in an area of intense urban and agricultural development. Project site is bordered to the north by an orchard and rural residence, to the south by a paved road (W Sierra Way), an orchard, and an abandoned vineyard. to the

east by a paved road (Road 72) and a community park; and to the west by a paved road (Road 70), a rural residence, and an orchard. A commercial distribution facility bordered the Project site to the northeast.

RESPONSES

- a) Substantially impair an adopted emergency response plan or emergency evacuation plan?
- b) Due to slope, prevailing winds, and other factors, exacerbate wildfire risks, and thereby expose project occupants to, pollutant concentrations from a wildfire or the uncontrolled spread of a wildfire?
- c) Require the installation or maintenance of associated infrastructure (such as roads, fuel breaks, emergency water sources, power lines or other utilities) that may exacerbate fire risk or that may result in temporary or ongoing impacts to the environment?
- d) Expose people or structures to significant risks, including downslope or downstream flooding or landslides, as a result of runoff, post-fire slope instability, or drainage changes?

Less Than Significant Impact. The proposed Project is located in an area developed with rural residential, industrial, and agricultural uses, which precludes the risk of wildfire. The area is flat in nature which would limit the risk of downslope flooding and landslides, and limit any wildfire spread. The proposed Project does not require the installation or maintenance of associated infrastructure that would increase wildfire risk or result in impacts to the environment. To receive building permits, the proposed Project would be required to be in compliance with the adopted emergency response plan. As such, any wildfire risk to the project structures or people would be *less than significant*.

Mitigation Measures: None are required.

XXI. MANDATORY FINDINGS OF SIGNIFICANCE

Would the project:

Potentially Significant Impact	Less than Significant With Mitigation Incorporation	Less than Significant Impact	No Impact
--------------------------------	---	------------------------------	-----------

- a. Does the project have the potential to degrade the quality of the environment, substantially reduce the habitat of a fish or wildlife species, cause a fish or wildlife population to drop below self-sustaining levels, threaten to eliminate a plant or animal community, reduce the number or restrict the range of a rare or endangered plant or animal or eliminate important examples of the major periods of California history or prehistory?

<input type="checkbox"/>	<input checked="" type="checkbox"/>	<input type="checkbox"/>	<input type="checkbox"/>
--------------------------	-------------------------------------	--------------------------	--------------------------

- b. Does the project have impacts that are individually limited, but cumulatively considerable? (“Cumulatively considerable” means that the incremental effects of a project are considerable when viewed in connection with the effects of past projects, the effects of other current projects, and the effects of probable future projects)?

<input type="checkbox"/>	<input type="checkbox"/>	<input checked="" type="checkbox"/>	<input type="checkbox"/>
--------------------------	--------------------------	-------------------------------------	--------------------------

- c. Does the project have environmental effects which will cause substantial adverse effects on human beings, either directly or indirectly?

<input type="checkbox"/>	<input checked="" type="checkbox"/>	<input type="checkbox"/>	<input type="checkbox"/>
--------------------------	-------------------------------------	--------------------------	--------------------------

RESPONSES

- a) Does the project have the potential to degrade the quality of the environment, substantially reduce the habitat of a fish or wildlife species, cause a fish or wildlife population to drop below self-sustaining levels, threaten to eliminate a plant or animal community, reduce the number or restrict

the range of a rare or endangered plant or animal or eliminate important examples of the major periods of California history or prehistory?

Less Than Significant Impact With Mitigation. The analyses of environmental issues contained in this Initial Study indicate that the proposed Project is not expected to have a substantial impact on the environment or on any resources identified in the Initial Study. Mitigation measures have been incorporated in the Project to reduce all potentially significant impacts to *less than significant*.

b) Does the project have impacts that are individually limited, but cumulatively considerable? (“Cumulatively considerable” means that the incremental effects of a project are considerable when viewed in connection with the effects of past projects, the effects of other current projects, and the effects of probable future projects)?

Less Than Significant Impact. CEQA Guidelines Section 15064(i) states that a Lead Agency shall consider whether the cumulative impact of a project is significant and whether the effects of the project are cumulatively considerable. The assessment of the significance of the cumulative effects of a project must, therefore, be conducted in connection with the effects of past projects, other current projects, and probable future projects. Due to the nature of the Project and consistency with environmental policies, incremental contributions to impacts are considered less than cumulatively considerable. The proposed Project would not contribute substantially to adverse cumulative conditions, or create any substantial indirect impacts (i.e., increase in population could lead to an increased need for housing, increase in traffic, air pollutants, etc.). The impact is *less than significant*.

c) Does the project have environmental effects which will cause substantial adverse effects on human beings, either directly or indirectly?

Less Than Significant Impact With Mitigation. The analyses of environmental issues contained in this Initial Study indicate that the Project is not expected to have substantial impact on human beings, either directly or indirectly. Mitigation measures have been incorporated in the Project to reduce all potentially significant impacts to *less than significant*.

LIST OF PREPARERS

Crawford & Bowen Planning, Inc.

- Emily Bowen, LEED AP, Principal Environmental Planner
- Travis Crawford, AICP, Principal Environmental Planner
- Deepesh Tourani, Associate Environmental Planner

JJM Air Quality Consulting Services

- Richard Miller
- Kimber Johnson

Colibri Ecological Consulting, LLC

- Ryan Slezak

JLB Traffic Engineering

- Jose Luis Benavides, PE, TE
- Matthew Arndt, EIT

Persons and Agencies Consulted

City of Dinuba

- Karl Schoettler, Contract City Planner

Southern San Joaquin Valley Information Center

- Jeremy E. David, Assistant Coordinator

Appendix A

Air Quality, Health Risk, Greenhouse Gas and Energy Technical Memorandum

Appendix B

Biological Resource Evaluation

Appendix C

CHRIS Cultural Resources Records Search

Appendix D

Traffic Impact Analysis Report

Appendix E

Vehicle Miles Traveled Analysis



Biological Resource Evaluation

December 2023

Dinuba Residential Development Project

Tulare County, CA

Prepared for:

Crawford & Bowen Planning, Inc.

113 N. Church Street, Suite 310

Visalia, CA 93291

Prepared by:

Colibri Ecological Consulting, LLC

9493 N Fort Washington Road, Suite 108

Fresno, CA 93730

colibri-ecology.com

Executive Summary

The applicant proposes to construct a single-family residential development in Dinuba, Tulare County, California. The proposed residential development project (Project) will involve construction on approximately 18.59 acres that currently supports a recently disced agricultural field, an agricultural ditch, and two rural residential structures and associated outbuildings.

To evaluate whether the Project may affect biological resources under California Environmental Quality Act (CEQA) purview, we (1) obtained lists of special-status species from the United States Fish and Wildlife Service, the California Department of Fish and Wildlife, and the California Native Plant Society; (2) reviewed other relevant background information such as satellite imagery and topographic maps; and (3) conducted a field reconnaissance survey at the Project site.

This biological resource evaluation summarizes (1) existing biological conditions on the Project site, (2) the potential for special-status species and regulated habitats to occur on or near the Project site, (3) the potential impacts of the proposed Project on biological resources and regulated habitats, and (4) measures to reduce those potential impacts to less-than-significant levels under CEQA.

We concluded the Project may affect one special-status plant species, four special-status animal species, and nesting migratory birds. The Project could also adversely affect one potentially regulated habitat, an agricultural drainage ditch. However, effects can be reduced to less-than-significant levels with mitigation.



Contents

- Abbreviations 5
- 1.0 Introduction..... 6
 - 1.1 Background 6
 - 1.2 Project Description 6
 - 1.3 Project Location 6
 - 1.4 Regulatory Framework 9
 - 1.4.1 State Requirements 9
 - 1.4.2 Federal Requirements 11
- 2.0 Methods..... 13
 - 2.1 Desktop Review 13
 - 2.2 Reconnaissance Survey 13
 - 2.3 Significance Criteria 14
- 3.0 Results..... 17
 - 3.1 Desktop Review 17
 - 3.2 Reconnaissance Survey 27
 - 3.2.1 Land Use and Habitats..... 27
 - 3.2.2 Plant and Animal Species Observed 30
 - 3.2.3 Nesting Birds..... 32
 - 3.2.4 Regulated Habitats 32
 - 3.3 Special-Status Species 32
 - 3.3.1 Sanford’s Arrowhead..... 33
 - 3.3.2 Swainson’s Hawk..... 33
 - 3.3.3 Burrowing Owl..... 34
 - 3.3.4 American Badger 34
 - 3.3.5 Pallid Bat 35
- 4.0 Environmental Impacts 37
 - 4.1 Significance Determinations 37
 - 4.1.1 Direct and Indirect Effects..... 38
- 5.0 Literature Cited 42



Figures

Figure 1. Project site vicinity map..... 7

Figure 2. Project site map..... 8

Figure 3. Reconnaissance survey area map.....16

Figure 4. CNDDDB occurrence map.26

Figure 5. Photograph from south-central portion of the Project site, looking east, showing a recently disced field with a community park in the background.....27

Figure 6. Photograph from the northwest corner of the Project site, looking south, showing a recently disced field and residences.....28

Figure 7. Photograph from the west-central portion of the Project site, looking north, showing a recently disced field with an orchard in the background.....28

Figure 8. Photograph from the northeast corner of the Project site, looking south, showing Horsman Ditch.....29

Figure 9. Photograph from the southeast corner of the Project site, looking west, showing Horsman Ditch as it enters a box culvert under West Sierra Way.29

Figure 10. Photograph of the side walls of burrow entrance exhibiting the distinctive long, sweeping claw marks of an American badger.....35

Tables

Table 1. Special-status species, their listing status, habitats, and potential to occur on or near the Project site..... 18

Table 2. Plant and animal species observed during the reconnaissance survey. 30

Appendices

Appendix A. USFWS list of threatened and endangered species.....45

Appendix B. CNDDDB occurrence records.....46

Appendix C. CNPS plant list.....47

Appendix D. Recommended timing and methodology for Swainson’s hawk nesting surveys in California’s Central Valley.....48

Appendix E. Staff report regarding mitigation for impacts to Swainson’s hawk (*Buteo swainsoni*) in the Central Valley of California.....49



Abbreviations

Abbreviation	Definition
CCR	California Code of Regulations
CDFG	California Department of Fish and Game
CDFW	California Department of Fish and Wildlife
CESA	California Endangered Species Act
CEQA	California Environmental Quality Act
CFGC	California Fish and Game Code
CFR	Code of Federal Regulations
CNDDDB	California Natural Diversity Data Base
CNPS	California Native Plant Society
CRPR	California Rare Plant Rank
FE	Federally listed as Endangered
FC	Federal Candidate for listing under the FESA
FESA	Federal Endangered Species Act
FP	State Fully Protected
FT	Federally listed as Threatened
MBTA	Migratory Bird Treaty Act
NRCS	Natural Resources Conservation Science
SC	State Candidate for listing under the CESA
SE	State listed as Endangered
SSSC	State Species of Special Concern
ST	State listed as Threatened
SWRCB	State Water Resources Control Board
USACE	United States Army Corps of Engineers
USC	United States Code
USFWS	United States Fish and Wildlife Service
USGS	United States Geological Survey



1.0 Introduction

1.1 Background

The applicant proposes to construct a 76-unit single-family residential development project (Project) on approximately 18.59 acres, comprising Assessor Parcel Number 012-290-011, in Dinuba, Tulare County, California. The Project site currently supports a recently disced agricultural field, an agricultural ditch, and two rural residential structures and associated outbuildings.

The purpose of this biological resource evaluation is to assess whether the Project will affect protected biological resources pursuant to California Environmental Quality Act (CEQA) guidelines. Such resources include species of plants or animals listed or proposed for listing under the Federal Endangered Species Act (FESA) or the California Endangered Species Act (CESA) as well as those covered under the Migratory Bird Treaty Act (MBTA), the California Native Plant Protection Act, and various other sections of California Fish and Game Code (CFGC). This biological resource evaluation also addresses Project-related impacts to regulated habitats, which are those under the jurisdiction of the United States Army Corps of Engineers (USACE), State Water Resources Control Board (SWRCB), or California Department of Fish and Wildlife (CDFW).

1.2 Project Description

This Project will involve constructing a 76-unit single-family residential subdivision and reconfiguring Horsman Ditch, on the east side of the Project site, into an underground culvert.

1.3 Project Location

The 18.59-acre Project site is on the northeast corner of Road 70 and West Sierra Way in Dinuba, Tulare County, California (Figures 1 and 2). The Project site is bounded by Road 72 to the east.

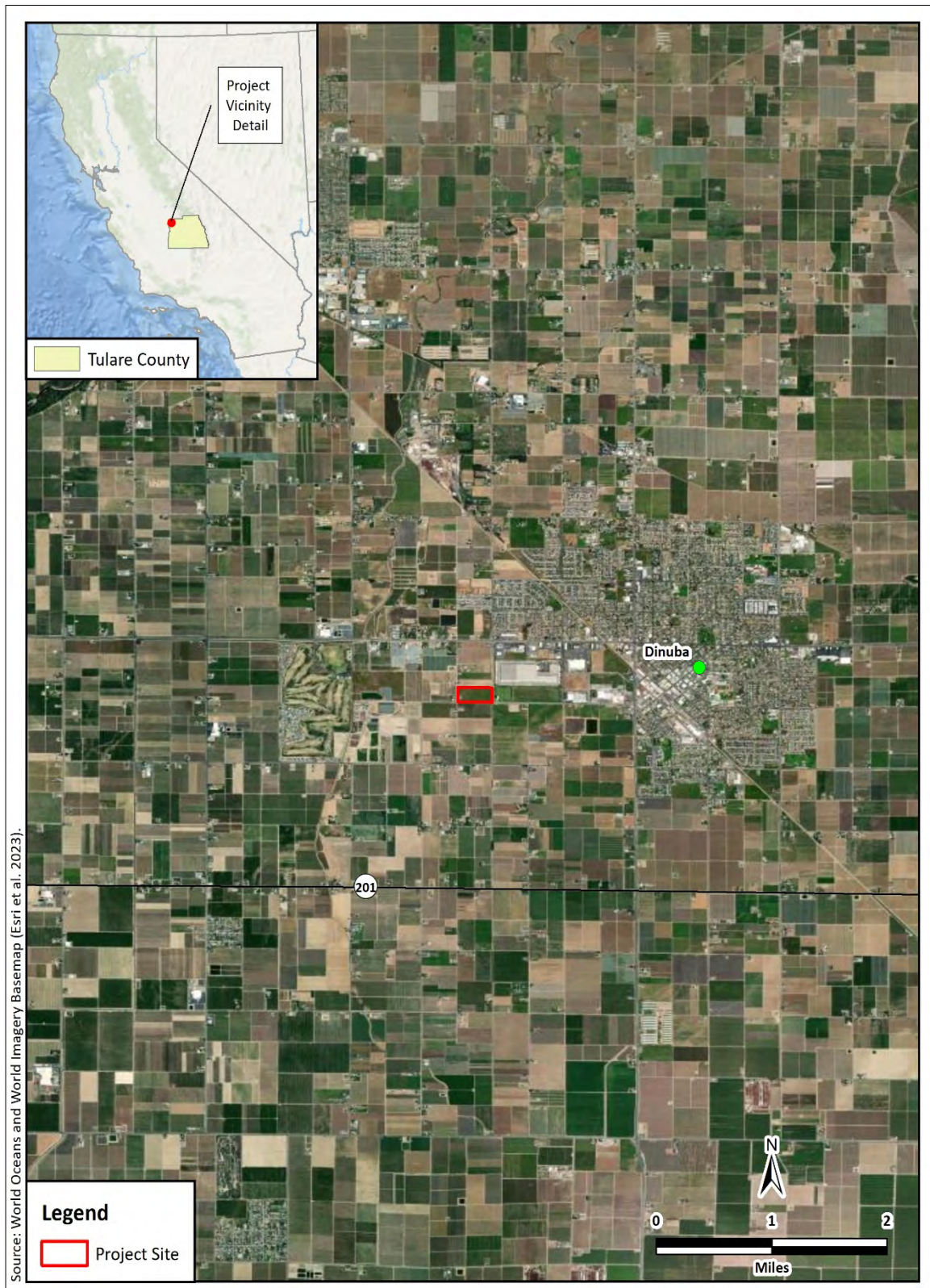

Figure 1. Project site vicinity map.



Figure 2. Project site map.



1.4 Regulatory Framework

The relevant regulatory requirements and policies that guide the impact analysis of the Project are summarized below.

1.4.1 State Requirements

California Department of Fish and Wildlife Jurisdiction. The CDFW has regulatory jurisdiction over lakes and streams in California. Activities that divert or obstruct the natural flow of a stream; substantially change its bed, channel, or bank; or use any materials (including vegetation) from the streambed may require that the project applicant enter into a Lake and Streambed Alteration Agreement with the CDFW in accordance with California Fish and Game Code [CFGC] Section 1602.

California Endangered Species Act. The CESA of 1970 (CFGC Section 2050 et seq. and California Code of Regulations (CCR) Title 14, Subsection 670.2, 670.51) prohibits the take of species listed under CESA (14 CCR Subsection 670.2, 670.5). Take is defined as hunt, pursue, catch, capture, or kill or attempt to hunt, pursue, catch, capture, or kill. Under CESA, state agencies are required to consult with the CDFW when preparing CEQA documents. Consultation ensures that proposed projects or actions do not adversely affect state listed species. During consultation, CDFW determines whether take would occur and identifies “reasonable and prudent alternatives” for the project and conservation of special-status species. CDFW can authorize take of state listed species under Sections 2080.1 and 2081(b) of the CFGC in those cases where it is demonstrated the impacts are minimized and mitigated. Take authorized under section 2081(b) must be minimized and fully mitigated. A CESA permit must be obtained if a project will result in take of listed species, either during construction or over the life of the project. Under CESA, CDFW is responsible for maintaining a list of threatened and endangered species designated under state law (CFGC Section 2070). CDFW also maintains lists of species of special concern, which serve as “watch lists.” Pursuant to the requirements of CESA, a state or local agency reviewing a proposed project within its jurisdiction must determine whether the proposed project will have a potentially significant impact upon such species. Project-related impacts to species on the CESA list would be considered significant and would require mitigation. Impacts to species of concern or fully protected species would be considered significant under certain circumstances.

California Environmental Quality Act. The California Environmental Quality Act (CEQA) of 1970 (Subsections 21000–21178) requires that CDFW be consulted



during the CEQA review process regarding impacts of proposed projects on special-status species. Special-status species are defined under CEQA Guidelines subsection 15380(b) and (d) as those listed under FESA and CESA and species that are not currently protected by statute or regulation but would be considered rare, threatened, or endangered under these criteria or by the scientific community. Therefore, species considered rare or endangered are addressed in this biological resource evaluation regardless of whether they are afforded protection through any other statute or regulation. The California Native Plant Society (CNPS) inventories the native flora of California and ranks species according to rarity (CNPS 2023). Plants with Rare Plant Ranks 1A, 1B, 2A, or 2B are considered special-status species under CEQA.

Although threatened and endangered species are protected by specific federal and state statutes, CEQA Guidelines Section 15380(d) provides that a species not listed on the federal or state list of protected species may be considered rare or endangered if it can be shown to meet certain specified criteria. These criteria have been modeled after the definition in the FESA and the section of the CFGC dealing with rare and endangered plants and animals. Section 15380(d) allows a public agency to undertake a review to determine if a significant effect on species that have not yet been listed by either the United States Fish and Wildlife Service (USFWS) or CDFW (i.e., candidate species) would occur. Thus, CEQA provides an agency with the ability to protect a species from the potential impacts of a project until the respective government agency has an opportunity to designate the species as protected, if warranted.

California Native Plant Protection Act. The California Native Plant Protection Act of 1977 (CFGC Sections 1900–1913) requires all state agencies to use their authority to carry out programs to conserve endangered and otherwise rare species of native plants. Provisions of the act prohibit the taking of listed plants from the wild and require the project proponent to notify CDFW at least 10 days in advance of any change in land use, which allows CDFW to salvage listed plants that would otherwise be destroyed.

Nesting birds. CFGC Sections 3503, 3503.5, and 3800 prohibit the possession, incidental take, or needless destruction of birds, their nests, and eggs. CFGC Section 3511 lists birds that are “Fully Protected” as those that may not be taken or possessed except under specific permit.

Porter-Cologne Water Quality Control Act. The Porter-Cologne Water Quality Control Act (California Water Code *Section* 13000 et. sec.) was established in 1969 and entrusts the SWRCB and nine Regional Water Quality Control Boards (collectively Water Boards) with the responsibility to preserve and enhance all



beneficial uses of California's diverse waters. The Act grants the Water Boards authority to establish water quality objectives and regulate point- and nonpoint-source pollution discharge to the state's surface and ground waters. Under the auspices of the United States Environmental Protection Agency, the Water Boards are responsible for certifying, under Section 401 of the federal Clean Water Act, that activities affecting waters of the United States comply with California water quality standards. The Porter-Cologne Water Quality Control Act addresses all "waters of the State," which are more broadly defined than waters of the United States. Waters of the State include any surface water or groundwater, including saline waters, within the boundaries of the state. They include artificial as well as natural water bodies and federally jurisdictional and federally non-jurisdictional waters. The Water Boards may issue a Waste Discharge Requirement permit for projects that will affect only federally non-jurisdictional waters of the State.

1.4.2 Federal Requirements

Federal Endangered Species Act. The USFWS and the National Oceanographic and Atmospheric Administration's National Marine Fisheries Service enforce the provisions stipulated in the FESA of 1973 (FESA, 16 United States Code [USC] Section 1531 et seq.). Threatened and endangered species on the federal list (50 Code of Federal Regulations [CFR] 17.11 and 17.12) are protected from take unless a Section 10 permit is granted to an entity other than a federal agency or a Biological Opinion with incidental take provisions is rendered to a federal lead agency via a Section 7 consultation. Take is defined as harass, harm, pursue, hunt, shoot, wound, kill, trap, capture, or collect or attempt to engage in any such conduct. Pursuant to the requirements of the FESA, an agency reviewing a proposed action within its jurisdiction must determine whether any federally listed species may be present in the proposed action area and determine whether the proposed action may affect such species. Under the FESA, habitat loss is considered an effect to a species. In addition, the agency is required to determine whether the proposed action is likely to jeopardize the continued existence of any species that is listed or proposed for listing under the FESA (16 USC Section 1536[3], [4]). Therefore, proposed action-related effects to these species or their habitats would be considered significant and would require mitigation.

Migratory Bird Treaty Act. The federal MBTA (16 USC Section 703, Supp. I, 1989) prohibits killing, possessing, trading, or other forms of take of migratory birds except in accordance with regulations prescribed by the Secretary of the Interior. "Take" is defined as the pursuing, hunting, shooting, capturing, collecting, or killing of birds, their nests, eggs, or young (16 USC Section 703 and Section 715n).



This act encompasses whole birds, parts of birds, and bird nests and eggs. The MBTA specifically protects migratory bird nests from possession, sale, purchase, barter transport, import, and export, and take. For nests, the definition of take per 50 CFR 10.12 is to collect. The MBTA does not include a definition of an “active nest.” However, the “Migratory Bird Permit Memorandum” issued by the USFWS in 2003 and updated in 2018 clarifies the MBTA in that regard and states that the removal of nests, without eggs or birds, is legal under the MBTA, provided no possession (which is interpreted as holding the nest with the intent of retaining it) occurs during the destruction (USFWS 2018).

United States Army Corps of Engineers Jurisdiction. Areas meeting the regulatory definition of “waters of the United States” (jurisdictional waters) are subject to the jurisdiction of the USACE under provisions of Section 404 of the Clean Water Act (1972) and Section 10 of the Rivers and Harbors Act (1899). These waters may include all waters used, or potentially used, for interstate commerce, including all waters subject to the ebb and flow of the tide, the territorial seas, all interstate waters, all impoundments of waters otherwise defined as waters of the United States, tributaries of waters otherwise defined as waters of the United States that are relatively permanent, standing, or continuously flowing bodies of water, and relatively permanent, standing or continuously flowing bodies of water with a continuous surface connection to waters of the United States (33 CFR part 328.3). Waters of the United States do not include prior converted cropland, waste treatment systems, ditches, artificially irrigated areas, artificial lakes or ponds, artificial reflecting pools or swimming pools, waterfilled depressions, and swales and erosional features. Under the 2006 Supreme Court ruling *Rapanos v. United States*, waters of the United States include non-navigable tributaries of traditional navigable waters that are relatively permanent. The 2023 Supreme Court ruling *Sackett v. Environmental Protection Agency* removed the significant nexus standard for tributaries and adjacent waters of the United States and requires tributaries and adjacent waters to have a continuous surface connection to a water of the United States. Wetlands on non-agricultural lands are identified using the *Corps of Engineers Wetlands Delineation Manual and related Regional Supplement* (USACE 1987 and 2008). Construction activities, including direct removal, filling, hydrologic disruption, or other means in jurisdictional waters are regulated by the USACE. The placement of dredged or fill material into such waters must comply with permit requirements of the USACE. No USACE permit will be effective in the absence of state water quality certification pursuant to Section 401 of the Clean Water Act. The State Water Resources Control Board is the state agency, together with the Regional Water Quality Control Boards, charged with implementing water quality certification in California.



2.0 Methods

2.1 Desktop Review

As a framework for the evaluation and reconnaissance survey, we obtained a USFWS species list for the Project (USFWS 2023a, Appendix A). In addition, we searched the California Natural Diversity Database (CNDDDB, CDFW 2023, Appendix B) and the CNPS Inventory of Rare and Endangered Plants (CNPS 2023, Appendix C) for records of special-status plant and animal species from the vicinity of the Project site. Regional lists of special-status species were compiled using CNDDDB and CNPS database searches confined to the Reedley 7.5-minute United States Geological Survey (USGS) topographic quadrangle, which encompasses the Project site, and the eight surrounding quadrangles (Burriss Park, Monson, Orange Cove North, Orange Cove South, Sanger, Selma, Traver, and Wahtoke). A local list of special-status species was compiled using CNDDDB records from within 5 miles of the Project site. Species that lacked a CEQA-recognized special-status designation by state or federal regulatory agencies or public interest groups were omitted from the final list. Species for which the Project site does not provide habitat were eliminated from further consideration. We also reviewed satellite imagery from Google Earth (Google 2023) and other sources, USGS topographic maps, the Web Soil Survey (NRCS 2023), the National Wetlands Inventory (USFWS 2023b), and relevant literature.

2.2 Reconnaissance Survey

Colibri Senior Technical Specialist Norman Sisk conducted a field reconnaissance survey of the Project site on 29 November 2023. The Project site and a 50-foot buffer (Figure 3) surrounding the Project site were walked and thoroughly inspected to evaluate and document the potential for the area to support state or federally protected resources. All plants except those under cultivation or planted in residential areas and all vertebrate wildlife species observed within the survey area were identified and documented. The survey area was evaluated for the presence of regulated habitats, including lakes, streams, and other waters as defined by the USACE, CDFW, and under the Porter-Cologne Water Quality Control Act. An additional buffer of 0.5 miles around the Project site was inspected for potential nesting habitat for special-status raptors (Figure 3). The 0.5-mile buffer was surveyed by driving public roads and identifying the presence of large trees or other potentially suitable substrates for nesting raptors as well as open areas that could provide foraging habitat.



2.3 Significance Criteria

CEQA defines “significant effect on the environment” as “a substantial, or potentially substantial, adverse change in the environment” (California Public Resource Code § 21068). Under CEQA Guidelines Section 15065, a Project’s effects on biological resources are deemed significant where the Project would do the following:

- a) Substantially reduce the habitat of a fish or wildlife species,
- b) Cause a fish or wildlife population to drop below self-sustaining levels,
- c) Threaten to eliminate a plant or animal community, or
- d) Substantially reduce the number or restrict the range of a rare or endangered plant or animal.

In addition to the Section 15065 criteria, Appendix E within the CEQA Guidelines includes six additional impacts to consider when analyzing the effects of a project. Under Appendix E, a project’s effects on biological resources are deemed significant where the project would do any of the following:

- a) Have a substantial adverse effect, either directly or through habitat modifications, on any species identified as a candidate, sensitive, or special-status species in local or regional plans, policies, or regulations, or by the CDFW or USFWS;
- b) Have a substantial adverse effect on any riparian habitat or other sensitive natural community identified in local or regional plans, policies, regulations, or by the CDFW or USFWS;
- c) Have a substantial adverse effect on state or federally protected wetlands (including, but not limited to, marsh, vernal pool, coastal, etc.) through direct removal, filling, hydrological interruption, or other means;
- d) Interfere substantially with the movement of any native resident or migratory fish or wildlife species or with established native resident or migratory wildlife corridors, or impede the use of native wildlife nursery sites;
- e) Conflict with any local policies or ordinances protecting biological resources, such as a tree preservation policy or ordinance; or
- f) Conflict with the provisions of an adopted Habitat Conservation Plan, Natural Community Conservation Plan, or other approved local, regional, or state habitat conservation plan.



These criteria were used to determine whether the potential effects of the Project on biological resources qualify as significant.



Figure 3. Reconnaissance survey area map.



3.0 Results

3.1 Desktop Review

The USFWS species list for the Project included nine species listed as threatened, endangered, or proposed for listing under the FESA (USFWS 2023a, Table 1, Appendix A). None of those species could occur on or near the Project site (Table 1). As stated in the species list, the Project site occurs outside any proposed or designated USFWS critical habitat (USFWS 2023a, Appendix A).

Searching the CNDDDB for records of special-status species from the Tulare 7.5-minute USGS topographic quadrangle and the eight surrounding quadrangles produced 200 records of 39 species (Table 1, Appendix B). Of those 39 species, seven were not considered further because they are not CEQA-recognized as special-status species by state or federal regulatory agencies or public interest groups or are considered extirpated in California (Appendix B). Of the remaining 32 species, seven are known from within 5 miles of the Project site (Table 1, Figure 4). Of those seven species, four could occur on or near the Project site (Table 1). Those include burrowing owl (*Athene cunicularia*—SSSC), Swainson’s hawk (*Buteo swainsoni*—ST), pallid bat (*Antrozous pallidus*—SSSC), and Sanford’s arrowhead (*Sagittaria sanfordii*—1B.2). One species not identified in the nine-quad search, American badger (*Taxidea taxus*—SSSC) was determined to be present on the Project site based on sign observed during the 29 November 2023 reconnaissance survey.

Searching the CNPS inventory of rare and endangered plants of California yielded 23 species (CNPS 2023, Appendix C), 18 of which have a CRPR of 1 or 2 and four of which are also state or federally listed (Table 1). Three of those 23 plant species, all mentioned above, could occur on or near the Project site (Table 1).

The Project site is underlain by Calgro–Calgro, saline–Sodic, complex, 0 to 2 percent slopes; Flamen loam, 0 to 2 percent slopes; and Tujunga loamy sand, 0 to 2 percent slopes (NCRS 2023). The Project site has little topographic relief and is at an elevation of 322–327 feet above mean sea level (Google 2023).

**Table 1.** Special-status species, their listing status, habitats, and potential to occur on or near the Project site.

Species	Status ¹	Habitat	Potential to Occur ²
Federally and State-Listed Endangered or Threatened Species			
Greene's tuctoria (<i>Tuctoria greenei</i>)	FE, SR, 1B.1	Vernal pools below 3500 feet elevation.	None. Habitat lacking; the survey area lacked vernal pools.
Hoover's spurge (<i>Euphorbia hooveri</i>)	FT, 1B.2	Vernal pools below 820 feet elevation.	None. Habitat lacking; the survey area lacked vernal pools.
San Joaquin adobe sunburst ³ (<i>Pseudobahia peirsonii</i>)	FT, SE, 1B.1	Grassland and bare dark clay at 300– 2700 feet elevation.	None. Habitat lacking; the survey area lacked clay soils.
San Joaquin Valley Orcutt grass (<i>Orcuttia inaequalis</i>)	FT, SE, 1B.1	Vernal pools at or below 2700 feet elevation.	None. Habitat lacking; the survey area lacked vernal pools.
Crotch bumble bee (<i>Bombus crotchii</i>)	SC	Open grassland and scrub habitats with abandoned rodent burrows for nesting and <i>Antirrhinum</i> , <i>Phacelia</i> , <i>Clarkia</i> , <i>Dendromecon</i> , <i>Eschscholzia</i> , and <i>Eriogonum</i> as food plants.	None. Habitat lacking; the survey area lacked food plants such as <i>Antirrhinum</i> , <i>Phacelia</i> , <i>Clarkia</i> , <i>Dendromecon</i> , <i>Eschscholzia</i> , or <i>Eriogonum</i> .



Species	Status ¹	Habitat	Potential to Occur ²
Monarch California overwintering population (<i>Danaus plexippus</i>)	FC	Groves of trees within 1.5 miles of the ocean that produce suitable micro-climates for overwintering such as high humidity, dappled sunlight, access to water and nectar, and protection from wind.	None. Habitat lacking; the survey area is not within 1.5 miles of the ocean.
Valley elderberry longhorn beetle ³ (<i>Desmocerus californicus dimorphus</i>)	FT	Elderberry (<i>Sambucus</i> sp.) plants having basal stem diameter greater than 1" at ground level.	None. The survey area is outside the currently recognized range of this species and lacked elderberry plants.
Vernal pool fairy shrimp (<i>Branchinecta lynchi</i>)	FT	Vernal pools; some artificial depressions, ditches, stock ponds, vernal swales, ephemeral drainages, and seasonal wetlands.	None. Habitat lacking; Horsman Ditch, along the eastern boundary of the Project site, is an active agricultural drain that periodically carries substantial flows, precluding its use by this species.
Vernal pool tadpole shrimp (<i>Lepidurus packardii</i>)	FE	Vernal pools, clay flats, alkaline pools, and ephemeral stock tanks.	None. Habitat lacking; the survey area lacked vernal pools or other potentially suitable aquatic features.
California tiger salamander (<i>Ambystoma californiense</i>)	FT, ST	Vernal pools or seasonal ponds for breeding; small mammal burrows for upland refugia in natural grasslands.	None. Habitat lacking; the survey area was not within the 1.5-mile dispersal distance of potential breeding pools.



Species	Status ¹	Habitat	Potential to Occur ²
Foothill yellow-legged frog - south Sierra DPS (<i>Rana boylei</i>)	SE, SSSC	Perennial streams and rivers with rocky substrates, and with open, sunny banks may be in forests, chaparral, or woodlands.	None. Habitat lacking; the survey area lacked the aquatic habitat this species requires.
Northwestern pond turtle (<i>Actinemys marmorata</i>)	FPT, SSSC	Ponds, rivers, marshes, streams, and irrigation ditches, usually with aquatic vegetation. Basking sites and suitable upland areas for egg laying.	None. Habitat lacking; the Project site and surrounding areas lacked the persistent aquatic habitat with adjacent natural lands this species requires.
California condor (<i>Gymnogyps californianus</i>)	FE, SE	Mountain and foothill rangeland with cliffs for nesting and grassland and open woodland for foraging.	None. Habitat lacking; the survey area is outside the local range of this species.
Swainson's hawk (<i>Buteo swainsoni</i>)	ST	Large trees for nesting with adjacent grasslands, alfalfa fields, or grain fields for foraging.	Moderate. Potential nest trees with nearby foraging habitat within the 0.5-mile survey area.
Western yellow-billed cuckoo (<i>Coccyzus americanus occidentalis</i>)	FT, SE	Open woodlands with dense, low vegetation along waterways.	None. Habitat lacking; the survey area lacked riparian woodlands.
Fresno kangaroo rat (<i>Dipodomys nitratoides exilis</i>)	FE, SE	Sandy, alkaline, saline, and clay soils in upland scrub and grassland.	None. Habitat lacking; the survey area lacked upland scrub and grassland.



Species	Status ¹	Habitat	Potential to Occur ²
San Joaquin kit fox (<i>Vulpes macrotis mutica</i>)	FE, ST	Grassland and upland scrub and fallowed agricultural lands adjacent to natural grasslands or upland scrub.	None. Habitat lacking; the agricultural land cover on the Project site lacked adjacent natural grassland or upland scrub.
State Species of Special Concern			
Northern leopard frog (<i>Lithobates pipiens</i>)	SSSC	Wet meadows, canals, bogs, marshes, and reservoirs in grassland, forest, and woodland.	None. Habitat lacking; the survey area is outside the current known range of this species.
Western spadefoot (<i>Spea hammondi</i>)	SSSC	Open areas with sandy or gravelly soil that allow rain pools to gather for breeding.	None. Habitat lacking; no vernal pools or other aquatic pools were present in the survey area.
Burrowing owl ³ (<i>Athene cunicularia</i>)	SSSC	Grassland and upland scrub with friable soil; some agricultural or other developed and disturbed areas with ground squirrel burrows.	Low. Ground squirrel burrows were present at multiple locations across the Project site during the 29 November 2023 reconnaissance survey; however, no burrowing owls or sign of burrowing owl use was observed at any burrow.
Loggerhead shrike (<i>Lanius ludovicianus</i>)	SSSC	Vast open areas with short vegetation and well-spaced shrubs or low trees for nesting.	None. Habitat lacking; the survey area lacked the vast open areas with well-spaced shrubs and low trees this species requires.



Species	Status ¹	Habitat	Potential to Occur ²
American badger (<i>Taxidea taxus</i>)	SSSC	Variable. Open, dry areas with friable soils and small mammal populations in grassland, conifer forest, and desert.	Present. One burrow with distinctive American badger claw marks was observed in the south-central portion of the Project site.
Pallid bat ³ (<i>Antrozous pallidus</i>)	SSSC	Arid or semi-arid locations in rocky areas and sparsely vegetated grassland near water. Rock crevices, caves, mine shafts, bridges, buildings, and tree hollows for roosting.	Moderate. An unoccupied, dilapidated residence on the Project site provides potential roosting habitat.
Western mastiff bat (<i>Eumops perotis californicus</i>)	SSSC	Cliff faces, high buildings, trees, and tunnels near open, arid areas.	None. Habitat lacking; the survey area lacked cliffs, high buildings, trees, or tunnels.
California Rare Plants			
Alkali sink goldfields (<i>Lasthenia chrysantha</i>)	1B.1	Vernal pools and wet saline flats below 320 feet elevation.	None. Habitat lacking; no vernal pools or wet saline flat habitats were present in the survey area.
Bristly sedge (<i>Carex comosa</i>)	2B.1	Coastal prairie, marshes and swamps (lake margins), and valley and foothill grasslands with wet soils below 2050 feet elevation.	None. Habitat lacking; no records from within 5 miles.



Species	Status ¹	Habitat	Potential to Occur ²
Brittlescale ³ (<i>Atriplex depressa</i>)	1B.2	Alkaline or clay soils in chenopod scrub, meadows and seeps, playas, valley and foothill grassland, and vernal pools below 1000 feet elevation.	None. Habitat lacking; the Project site consisted of agricultural and developed land covers and an agricultural ditch.
California alkali grass (<i>Puccinellia simplex</i>)	1B.2	Saline flats and mineral springs below 3000 feet elevation.	None. Habitat lacking; the Project site lacked saline flats and mineral springs.
California satintail ³ (<i>Imperata brevifolia</i>)	2B.1	Moist to wet sites in arid desert canyons, or rocky slopes, near seeps, springs, and streams below 1700 feet elevation.	None. Habitat lacking; the Project site consisted of agricultural and developed land covers and an agricultural ditch.
Coulter's goldfields (<i>Lasthenia glabrata</i> ssp. <i>coulteri</i>)	1B.1	Saltmarsh, playas, and vernal pools below 4000 feet elevation.	None. Habitat lacking; the survey area lacked saltmarsh, playas, and vernal pools.
Earlimart orache (<i>Atriplex cordulata</i> var. <i>erecticaulis</i>)	1B.2	Saline or alkaline soils in Central Valley and foothill grassland below 230 feet elevation.	None. Habitat lacking; the Project site consisted of agricultural and developed land covers and an agricultural ditch and is above the known elevational range of this species.
Heartscale (<i>Atriplex cordulata</i> var. <i>cordulata</i>)	1B.2	Saline or alkaline soils in grassland, meadows and seeps, and chenopod scrub communities below 230 feet elevation.	None. Habitat lacking; the Project site consisted of agricultural and developed land covers and an agricultural ditch and is above the known elevational range of this species.



Species	Status ¹	Habitat	Potential to Occur ²
Lesser saltscale (<i>Atriplex minuscula</i>)	1B.1	Sandy, alkaline soils in chenopod scrub, playa, and grassland in the San Joaquin Valley below 328 feet elevation.	None. Habitat lacking; the Project site consisted of agricultural and developed land covers and an agricultural ditch.
Recurved larkspur (<i>Delphinium recurvatum</i>)	1B.2	Poorly drained, fine, alkaline soils in grassland and saltbush scrub at 98–1969 feet elevation.	None. Habitat lacking; the Project site consisted of agricultural and developed land covers and an agricultural ditch.
Sanford’s arrowhead ³ (<i>Sagittaria sanfordii</i>)	1B.2	Ponds, sloughs, and ditches at sea level to 650 feet elevation.	Low. Horsman Ditch could support this species; however, no individual plants were observed during the 29 November 2023 reconnaissance survey.
Spiny-sepaled button-celery (<i>Eryngium spinosepalum</i>)	1B.2	Vernal pools and swales in valley and foothill grassland.	None. Habitat lacking; the survey area lacked vernal pools and swales.
Subtle orache (<i>Atriplex subtilis</i>)	1B.2	Saline depressions below 230 feet elevation.	None. Habitat lacking; the survey area lacked saline depressions.
Winter’s sunflower (<i>Helianthus winteri</i>)	1B.2	Steep, south-facing grassy slopes, rock outcrops, and road cuts at 590–1509 feet elevation.	None. Habitat lacking; the Project site is below the known elevational range of this species.

CDFW (2023), CNPS (2023), USFWS (2023a).



Status ¹	Potential to Occur ²
FC = Federal Candidate for Listing	None: Species or sign not observed; conditions unsuitable for occurrence.
FE = Federally listed as Endangered	Low: Neither species nor sign observed; conditions marginal for occurrence.
FT = Federally listed as Threatened	Moderate: Neither species nor sign observed; conditions suitable for occurrence.
FPT = Federally Proposed Threatened	High: Neither species nor sign observed; conditions highly suitable for occurrence.
FP = State Fully Protected	Present: Species or sign observed; conditions suitable for occurrence.
SC = State Candidate for listing	
SE = State listed as Endangered	
ST = State listed as Threatened	
SSSC = State Species of Special Concern	

CNPS California Rare Plant Rank ¹ :	Threat Ranks ¹ :
1B – plants rare, threatened, or endangered in California and elsewhere.	0.1 – seriously threatened in California (> 80% of occurrences).
2B – plants rare, threatened, or endangered in California but more common elsewhere.	0.2 – moderately threatened in California (20-80% of occurrences).
3 – plants about which more information is needed.	0.3 – not very threatened in California (<20% of occurrences).
4 – plants have limited distribution in California.	

³Record from within 5 miles of the Project site.

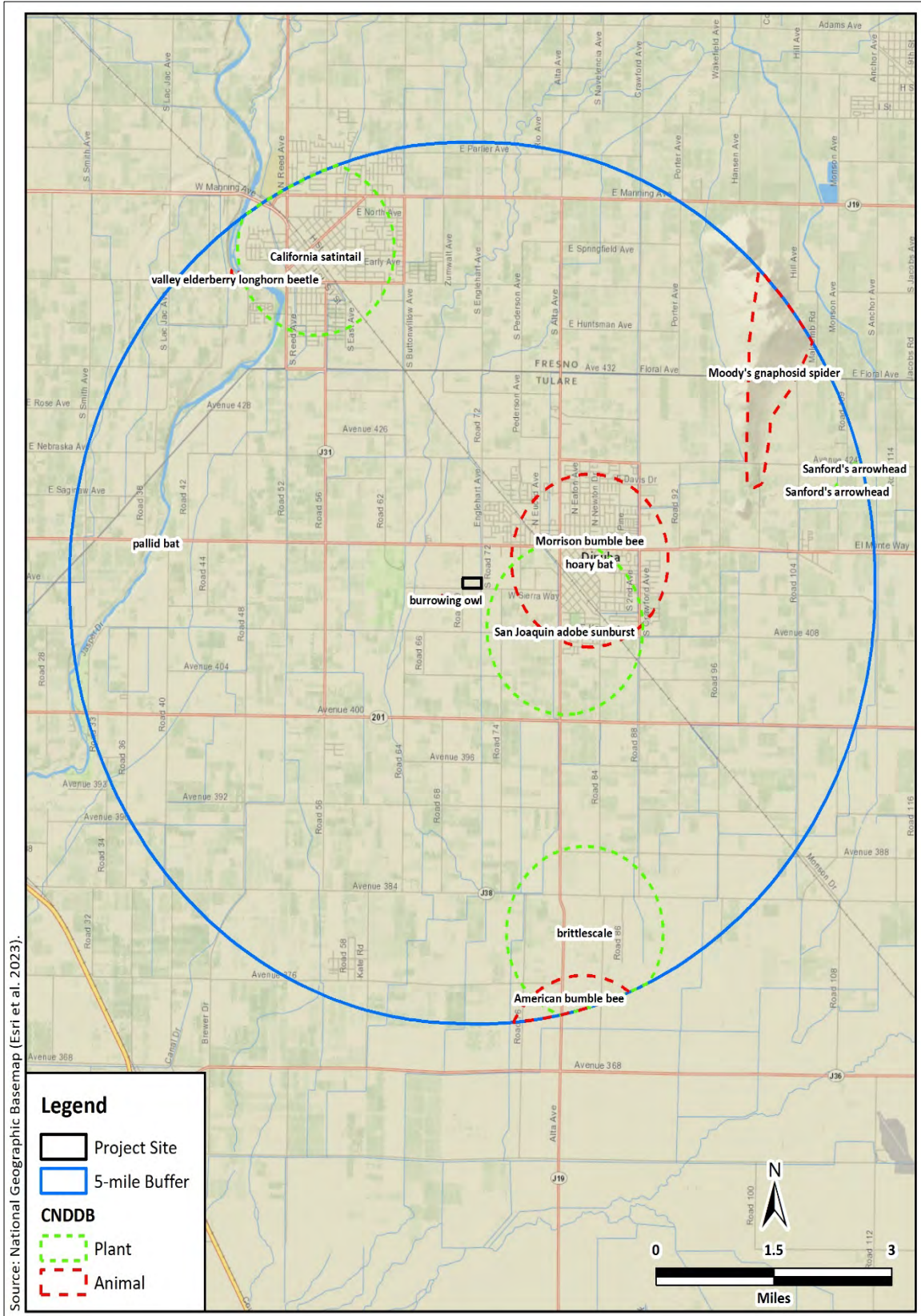

Figure 4. CNDDB occurrence map.



3.2 Reconnaissance Survey

3.2.1 Land Use and Habitats

The Project site supported a recently disced agricultural field (Figures 5–7). Two residential structures with outbuildings and ornamental trees were near its western boundary (Figure 6). The Project site was otherwise sparsely vegetated, mainly with ruderal, nonnative grasses and forbs. An earthen agricultural drainage ditch (Horsman Ditch) spanned the eastern boundary of the Project site (Figures 8 and 9). The Project site was bordered to the north by an orchard and rural residence (Figure 8); to the south by a paved road (W Sierra Way), an orchard, and an abandoned vineyard; to the east by a paved road (Road 72) and a community park; and to the west by a paved road (Road 70), a rural residence, and an orchard. A commercial distribution facility bordered the Project site to the northeast. The Project site was used as a hayfield since at least 2009 and for row crops prior to that (Google 2023).

Horseman Ditch, which lacked flowing water at the time of the survey, collects agricultural runoff from north of the Project site, draining to the south (Figures 2, 8, and 9) into two other agricultural ditches, King Ditch and Banks Ditch, and eventually into the St. Johns River. Horseman Ditch supported a mix of wetland and upland plant species.



Figure 5. Photograph from south-central portion of the Project site, looking east, showing a recently disced field with a community park in the background.



Figure 6. Photograph from the northwest corner of the Project site, looking south, showing a recently disced field and residences.



Figure 7. Photograph from the west-central portion of the Project site, looking north, showing a recently disced field with an orchard in the background.



Figure 8. Photograph from the northeast corner of the Project site, looking south, showing Horsman Ditch.



Figure 9. Photograph from the southeast corner of the Project site, looking west, showing Horsman Ditch as it enters a box culvert under West Sierra Way.



3.2.2 Plant and Animal Species Observed

A total of 23 plant species (7 native and 16 nonnative), nine bird species, and three mammal species were observed during the survey (Table 2).

Table 2. Plant and animal species observed during the reconnaissance survey.

Common Name	Scientific Name	Status
Plants		
Family Amaranthaceae		
Russian thistle	<i>Salsola tragus</i>	Nonnative
Family Asteraceae		
Canada horseweed	<i>Erigeron canadensis</i>	Native
Rough cocklebur	<i>Xanthium strumarium</i>	Native
Jersey cudweed	<i>Pseudognaphalium luteoalbum</i>	Nonnative
Prickly lettuce	<i>Lactuca serriola</i>	Nonnative
Family Brassicaceae		
Bog yellowcress	<i>Rorippa palustris</i>	Native
Wild radish	<i>Raphanus raphanistrum</i>	Nonnative
Family Cyperaceae		
Fragrant flatsedge	<i>Cyperus odoratus</i>	Native
Nutgrass	<i>Cyperus rotundus</i>	Nonnative
Family Juncaceae		
Wire rush	<i>Juncus balticus</i>	Native
Family Malvaceae		
Common mallow	<i>Malva neglecta</i>	Nonnative
Family Onagraceae		
California evening primrose	<i>Oenothera laciniata</i>	Nonnative
Floating water primrose	<i>Ludwigia peploides</i>	Nonnative
Family Poaceae		
Bearded sprangletop	<i>Diplachne fusca</i>	Native



Common Name	Scientific Name	Status
Bermuda grass	<i>Cynodon dactylon</i>	Nonnative
Cheatgrass	<i>Bromus tectorum</i>	Nonnative
Feather finger grass	<i>Chloris virgata</i>	Nonnative
Johnsongrass	<i>Sorghum halepense</i>	Nonnative
Ovate goatgrass	<i>Aegilops geniculata</i>	Nonnative
Ripgut brome	<i>Bromus diandrus</i>	Nonnative
Saltgrass	<i>Distichlis spicata</i>	Native
Family Polygonaceae		
Clustered dock	<i>Rumex conglomeratus</i>	Nonnative
Family Zygophyllaceae		
Goathead	<i>Tribulus terrestris</i>	Nonnative
Birds		
Family Accipitridae		
Red-tailed hawk	<i>Buteo jamaicensis</i>	MBTA, CFGC
Family Columbidae		
Eurasian collared-dove	<i>Streptopelia orientalis</i>	Nonnative
Family Corvidae		
California scrub-jay	<i>Apelocoma californica</i>	MBTA, CFGC
Common raven	<i>Corvus corax</i>	MBTA, CFGC
Family Emberizidae		
White-crowned sparrow	<i>Zonotrichia leucophrys</i>	MBTA, CFGC
Family Falconidae		
American kestrel	<i>Falco sparverius</i>	MBTA, CFGC
Family Passerellidae		
Lincoln's sparrow	<i>Melospiza lincolnii</i>	MBTA, CFGC
Savannah sparrow	<i>Passerculus sandwichensis</i>	MBTA, CFGC
Family Passeridae		
House sparrow	<i>Passer domesticus</i>	Nonative



Common Name	Scientific Name	Status
Mammals		
Family Geomyidae		
Botta's pocket gopher	<i>Thomomys bottae</i>	--
Family Mustelidae		
American badger (sign)	<i>Taxidea taxus</i>	SSSC
Family Sciuridae		
California ground squirrel	<i>Otospermophilus beecheyi</i>	--

MBTA = Protected under the MBTA (16 USC § 703 et seq.); CFGC = Protected under CFGC §§ 3503 and 3513; SSSC = State Species of Special Concern

3.2.3 Nesting Birds

Migratory birds could nest on or near the Project site. Bird species that may nest on or near the property include, but are not limited to, California scrub-jay (*Aphelocoma californica*) and house finch (*Haemorhous mexicanus*). Large trees within 0.5 miles of the Project site could provide nesting substrates for raptors, including Swainson's hawk (*Buteo swainsoni*).

3.2.4 Regulated Habitats

One potentially regulated habitat, Horseman Ditch, was found in the survey area: an earthen agricultural drainage ditch along the eastern boundary of the Project (Figures 2, 8, and 9). Horseman Ditch is listed in the National Wetlands Inventory as an intermittent riverine system with a classification of R4SBCx, which means riverine, intermittent, streambed, seasonally flooded, and excavated (USFWS 2023b). During the 29 November 2023 reconnaissance survey, Horseman Ditch had wet soil across its length within the Project site and contained standing water in the southernmost portion of the Project site. As a surface water in California, Horseman Ditch it is likely regulated by the SWRCB. As a waterway in California, it may also be regulated by the CDFW. And as it appears to be a tributary of the St. Johns River, of a water of the United States, it may fall under the regulatory jurisdiction of the USACE.

3.3 Special-Status Species

The following special-status species could occur on or near the Project site based on the presence of habitat:



3.3.1 Sanford's Arrowhead

Sanford's arrowhead is an aquatic emergent, rhizomatous perennial herb in the family Alismataceae with a CRPR of 1B.2. It is endemic to the Central Valley of California where it occupies ponds, ditches, sloughs, marshes, and slow-moving rivers below 984 feet elevation; it flowers May–October (Turner et al. 2012)

There are two CNDDDB occurrence records from 2001 known from within 5 miles of the Project site (CNDDDB 2023). This species was not detected during the reconnaissance survey, which occurred outside the flowering period. Horsman Ditch, along the east side of the Project site, could support this species. However, anthropogenic disturbance associated with agricultural operations limits habitat quality. Therefore, the potential for this species to occur on the Project site is low.

3.3.2 Swainson's Hawk

Swainson's hawk is a state listed as threatened raptor in the family Accipitridae. It is a migratory breeding resident of Central California. It uses open areas including grassland, sparse shrubland, pasture, open woodland, and annual agricultural fields such as grain and alfalfa to forage on small mammals, birds, and reptiles. After breeding, it eats mainly insects, especially grasshoppers (Bechard et al. 2020). Swainson's hawks build small to medium-sized nests in medium to large trees near foraging habitat. The nesting season begins in March or April in Central California when this species returns to its breeding grounds from wintering areas in Mexico and Central and South America. Nest building commences within one to two weeks of arrival to the breeding area and lasts about one week (Bechard et al. 2020). One to four eggs are laid and incubated for about 35 days. Young typically fledge in about 38–46 days and tend to leave the nest territory within 10 days of fledging (Bechard et al. 2020). Swainson's hawks depart for the non-breeding grounds between August and September.

Seven CNDDDB occurrence records of Swainson's hawk, from 1926–2017, were found in the nine-quad search; no CNDDDB occurrence records were found within 5 miles of the Project site. The fallow field on the Project site and surrounding lands provide foraging habitat for Swainson's hawk, and potential nest trees were observed within 0.5 miles of the Project site. Therefore, there is a moderate potential for Swainson's hawk to nest within 0.5 miles of the Project site.



3.3.3 Burrowing Owl

Burrowing owl is a member of the family Strigidae recognized as a species of special concern by the CDFW (2023). Burrowing owl occurs primarily in grassland but can persist and even thrive in agricultural or other developed and disturbed areas (Shuford and Gardali 2008, Rosenberg and Haley 2004). Burrowing owl depends on burrow systems excavated by other species such as California ground squirrel (*Otospermophilus beecheyi*) and American badger (*Taxidea taxus*) (Poulin et al. 2020). Burrowing owl uses burrows for protection from predators, weather, as roosting sites, and dwellings to raise young (Poulin et al. 2020). It commonly perches outside burrows on mounds of soil or nearby fence posts. Prey types include insects, especially grasshoppers and crickets, small mammals, frogs, toads, and lizards (Poulin et al. 2020). The nesting season begins in March, and incubation lasts 28–30 days. The female incubates the eggs while the male forages and delivers food items to the burrow-nest; young then fledge between 44 and 53 days after hatching (Poulin et al. 2020). Adults can live up to 8 years in the wild.

There is one CNDDDB occurrence record of burrowing owl from within 5 miles of the Project site (CDFW 2023). An additional 12 CNDDDB occurrence records were found in the nine-quad search (CDFW 2023). The nearest CNDDDB occurrence record of burrowing owl is from an agricultural field 0.2 miles southwest of the Project site. Ground squirrel burrows that could support this species were scattered throughout the Project site, and the Project site provides foraging habitat. However, the habitat is routinely disturbed, and no sign of burrowing owl was detected during the 29 November 2023 reconnaissance survey. Therefore, the potential for this species to occur on the Project site is low.

3.3.4 American Badger

American badger is a medium-sized fossorial carnivore in the family Mustelidae. It occurs throughout much of California. American badger resides primarily in open, early succession habitats such as arid and open shrubland, forest, and herbaceous habitat types with sparse vegetative cover and sandy soils (Apps et al. 2002). Friable soil is a key microhabitat requirement for this species, which digs burrows for shelter. American badger is carnivorous and preys on fossorial rodents. American badger has a large home range and is not known to migrate (Messick and Hornocker 1981). The American badger breeding season spans summer to early fall (Zeiner et al. 1988–1990). Once common in California, American badger is now considered a Species of Special Concern, primarily due to human encroachment including industrialized agriculture and urban



development (Williams 1986). Additional threats to American badger include vehicle strikes, disease, and secondary poisoning via rodenticides (Quinn 2015).

There were no CNDDDB occurrence records of American badger within the nine-quad search of the Project site (CDFW 2023). However, during the 29 November 2023 reconnaissance survey, one burrow large enough to support this species was observed in the south-central portion of the Project site. The side walls of the burrow entrance exhibited the distinctive long, sweeping claw marks of an American badger (Figure 10). No sign of occupation or recent use of the burrow, such as scat or the remains of prey items, were found in the immediate vicinity of the burrow, which probably indicates this burrow is no longer occupied by a badger. It is also possible that a badger never occupied this burrow but was attempting to dig out and depredate a ground squirrel in the burrow. Regardless, due to the presence American badger sign, this species is considered present on the Project site.



Figure 10. Photograph of the side walls of burrow entrance exhibiting the distinctive long, sweeping claw marks of an American badger.

3.3.5 Pallid Bat

Pallid bat is a member of the family Vespertilionidae and is recognized as a Species of Special Concern by the CDFW (CDFW 2023). It is widespread in the western United States from southern British Columbia, Canada to northern Baja



California, Mexico (Hermanson and O'Shea 1983). In California, pallid bat is locally common year-round at low elevations, where it occupies dry, open areas in grassland, shrubland, woodland, and forest (Zeiner et al. 1988–1990). Pallid bat is nocturnal and roosts during the day in caves, crevices in rocky outcrops, mines, and occasionally tree hollows and buildings; night roosts tend to be in more open areas including porches (Zeiner et al. 1988–1990). It forages almost exclusively on the ground, where it preys on insects, arachnids, beetles, moths, and scorpions; few prey items are taken aerially (Zeiner et al. 1988–1990). Pallid bat hibernates during winter, usually near a day roost that it occupies in summer (Hermanson and O'Shea 1983).

There is one CNDDDB occurrence record of pallid bat from within 5 miles of the Project site (CDFW 2023). Accessible roosting habitat was observed in an unoccupied, dilapidated residence near the western boundary of the Project site, and the surrounding agricultural lands may provide foraging habitat. This species has a moderate potential to occur on or near the Project site.



4.0 Environmental Impacts

4.1 Significance Determinations

This Project, which will result in temporary and permanent impacts to a recently disced agricultural field, an agricultural ditch, and two rural residential structures and associated outbuildings, will not: (1) substantially reduce the habitat of a fish or wildlife species (criterion a) as no such habitat is present on the Project site; (2) cause a fish or wildlife population to drop below self-sustaining levels (criterion b) as no such potentially vulnerable population is known from the area; (3) threaten to eliminate a plant or animal community (criterion c) as no such potentially vulnerable communities are known from the area; (4) substantially reduce the number or restrict the range of a rare or endangered plant or animal (criterion d) as no such potentially vulnerable species are known from the area; (5) have a substantial adverse effect on any riparian habitat or other sensitive natural community identified in local or regional plans, policies, regulations, or by the CDFW or USFWS (criterion f) as no riparian habitat or other sensitive natural community was present in the survey area; (6) have a substantial adverse effect on state or federally protected wetlands (including, but not limited to marsh, vernal pool, coastal, etc.) through direct removal, filling, hydrological interruption, or other means (criterion g) as no impacts to wetlands will occur; (7) conflict with any local policies or ordinances protecting biological resources, such as a tree preservation policy or ordinance (criterion i) as no such ordinances are pertinent to the Project; or (8) conflict with the provisions of an adopted Habitat Conservation Plan, Natural Communities Conservation Plan, or other approved local, regional, or state habitat conservation plan (criterion j) as no such plan has been adopted. Thus, these significance criteria are not analyzed further.

The remaining statutorily defined criteria provide the framework for Criterion BIO1 and Criterion BIO2 below. These criteria are used to assess the impacts to biological resources stemming from the Project and provide the basis for determinations of significance:

- Criterion BIO1: Have a substantial adverse effect, either directly or through habitat modifications, on any species identified as a candidate, sensitive, or special-status species in local or regional plans, policies, or regulations, or by the CDFW or USFWS (significance criterion e).



- **Criterion BIO2:** Interfere substantially with the movement of any native resident or migratory fish or wildlife species or with established native resident or migratory wildlife corridors, or impede the use of native wildlife nursery sites (significance criterion h).

4.1.1 Direct and Indirect Effects

4.1.1.1 Potential Effect #1: Have a Substantial Effect on Any Special-Status Species (Criterion BIO1)

The Project could adversely affect, either directly or through habitat modifications, one special-status plant species and four special-status animal species that occur or may occur on or near the Project site. Construction activities such as excavating, trenching, or using other heavy equipment that disturbs or harms a special-status species or substantially modifies its habitat could constitute a significant impact. We recommend that Mitigation Measures BIO1–BIO6 (below) be included in the conditions of approval to reduce the potential impacts to less-than-significant levels.

Mitigation Measure BIO1. Protect Sanford’s arrowhead.

1. A qualified biologist shall conduct a pre-construction survey for Sanford’s arrowhead at Horseman Ditch. The survey shall be timed to coincide with the May–October blooming period of the species.
2. If Sanford’s arrowhead is detected, the qualified biologist shall establish an exclusion zone of 50 feet between any population and the area of direct or indirect impacts. If a 50-foot exclusion zone cannot be established, a site-specific plan to minimize the potential for Project activities to affect individual plants shall be developed by the qualified biologist and implemented in consultation with the CDFW. Such a plan could involve conducting work after plant senescence and salvaging and relocating affected plants and associated topsoil.

Mitigation Measure BIO2. Protect nesting Swainson’s hawks.

1. To the extent practicable, construction shall be scheduled to avoid the Swainson’s hawk nesting season, which extends from March through August.
2. If it is not possible to schedule construction between September and February, a qualified biologist shall conduct surveys for Swainson’s



- hawk in accordance with the Swainson's Hawk Technical Advisory Committee's Recommended Timing and Methodology for Swainson's Hawk Nesting Surveys in California's Central Valley (SWTAC 2000, Appendix E). These methods require six surveys, three in each of the two survey periods, prior to project initiation. Surveys shall be conducted within a minimum 0.5-mile radius around the Project site.
3. If an active Swainson's hawk nest is found within 0.5 miles of the Project site, and the qualified biologist determines that Project activities would disrupt the nesting birds, a construction-free buffer or limited operating period shall be implemented in consultation with the CDFW.

Mitigation Measure BIO3. Compensate for loss of Swainson's hawk foraging habitat.

Compensate for loss of Swainson's hawk foraging habitat (i.e., agricultural lands on the Project site) in accordance with the CDFW Staff Report Regarding Mitigation for Impacts to Swainson's Hawks (*Buteo swainsoni*) in the Central Valley of California (CDFG 1994, Appendix F). The CDFW requires that projects adversely affecting Swainson's hawk foraging habitat provide Habitat Management (HM) lands to the department. Projects within 1 mile of an active nest shall provide one acre of HM lands for each acre of development authorized (1:1 ratio). Projects within 5 miles of an active nest but greater than 1 mile from the nest shall provide 0.75 acres of HM lands for each acre of urban development authorized (0.75:1 ratio). And projects within 10 miles of an active nest but greater than 5 miles from an active nest shall provide 0.5 acres of HM lands for each acre of urban development authorized (0.5:1 ratio). No compensation is required if an active nest is not found within 10 miles of the Project site.

Mitigation Measure BIO4. Protect burrowing owl.

1. Conduct focused burrowing owl surveys to assess the presence/absence of burrowing owl in accordance with the Staff Report on Burrowing Owl Mitigation (CDFG 2012) and Burrowing Owl Survey Protocol and Mitigation Guidelines (CBOC 1997). These involve conducting four pre-construction survey visits.
2. If a burrowing owl or sign of burrowing owl use (e.g., feathers, guano, pellets) is detected on or within 500 feet of the Project site, and the qualified biologist determines that Project activities would disrupt the



owl(s), a construction-free buffer, limited operating period, or passive relocation shall be implemented in consultation with the CDFW.

Mitigation Measure BIO5. Protect American badger.

Within 30 days prior to the start of construction or ground disturbing activities, a qualified biologist shall survey the Project site for American badger. If American badger is detected, the biologist shall passively relocate any individual out of the work area prior to construction if feasible. Potentially active and active dens that would be directly impacted by construction activities will be monitored for at least three consecutive nights using a wildlife-monitoring camera or tacking media at the entrance. If no photos or tracks of badgers are captured after three nights, the den will be excavated and backfilled by hand. In the event that passive relocation fails, the qualified biologist will consult with the CDFW to explore other relocation options, which may include trapping.

Mitigation Measure BIO6. Protect pallid bat.

A pre-construction clearance survey shall be conducted by a qualified biologist to ensure that no roosting pallid bats will be disturbed during the implementation of the Project. A pre-construction clearance survey shall be conducted no more than 14 days prior to the initiation of construction activities. During this survey, the qualified biologist shall inspect all potential roosting habitat in and immediately adjacent to the impact areas. If an active roost is found close enough to the construction area to be disturbed by these activities, the qualified biologist shall determine the extent of a construction-free buffer to be established around the roost. If work cannot proceed without disturbing the roosting bats, work may need to be halted or redirected to other areas until the roost is no longer in use.

4.1.1.2 Potential Effect #2: Interfere Substantially with Native Wildlife Movements, Corridors, or Nursery Sites (Criterion BIO2)

The Project has the potential to impede the use of nursery sites for native birds protected under the MBTA and CFGC. Migratory birds are expected to nest on and near the Project site. Construction disturbance during the breeding season could result in the incidental loss of fertile eggs or nestlings or otherwise lead to nest abandonment. Disturbance that causes nest abandonment or loss of reproductive effort can be considered take under the MBTA and CFGC. Loss of fertile eggs or nesting birds, or any activities resulting in nest abandonment, could constitute a significant



effect if the species is particularly rare in the region. Construction activities such as excavating, trenching, and grading that disturb a nesting bird in the Project site or immediately adjacent to the construction zone could constitute a significant effect. We recommend that the mitigation measure BIO7 (below) be included in the conditions of approval to reduce the potential effect to a less-than-significant level.

Mitigation Measure BIO7. Protect nesting birds.

1. To the extent practicable, construction shall be scheduled to avoid the nesting season, which extends from February through August.
2. If it is not possible to schedule construction between September and January, pre-construction surveys for nesting birds shall be conducted by a qualified biologist to ensure that no active nests will be disturbed during the implementation of the Project. A pre-construction survey shall be conducted no more than 14 days prior to the initiation of construction activities. During this survey, the qualified biologist shall inspect all potential nest substrates in and immediately adjacent to the impact areas. If an active nest is found close enough to the construction area to be disturbed by these activities, the qualified biologist shall determine the extent of a construction-free buffer to be established around the nest. If work cannot proceed without disturbing the nesting birds, work may need to be halted or redirected to other areas until nesting and fledging are completed or the nest has otherwise failed for non-construction related reasons.



5.0 Literature Cited

- Apps, C. D., N. J. Newhouse, and T. A. Kinley. 2002. Habitat associations of American badgers in southeast British Columbia. *Canadian Journal of Zoology* 80:1228–1239.
- Barbour, R. W., and W. H. Davis. 1969. *Bats of America*. University of Kentucky Press, Lexington. 286 pp.
- Bechard, M. J., C. S. Houston, J. H. Saransola, and A. S. England. 2020. Swainson's Hawk (*Buteo swainsoni*), version 1.0. *In* *Birds of the World* (A. F. Poole, Editor). Cornell Lab of Ornithology, Ithaca, NY, USA. <https://doi.org/10.2173/bow.swahaw.01>.
- California Department of Fish and Game (CDFG). 1994. Staff Report Regarding Mitigation for Impacts to Swainson's Hawk (*Buteo swainsoni*) in the Central Valley of California. California Nongame Bird and Mammal Section Report #94.18.
- _____. 2012. Staff Report on Burrowing Owl Mitigation, State of California Natural Resources Agency, Department of Fish and Game. 36 pp.
- California Department of Fish and Wildlife (CDFW). 2018. Protocols for Surveying and Evaluating Impacts to Special Status Native Plant Populations and Sensitive Natural Communities. The Resources Agency, California Department of Fish and Wildlife Sacramento, CA.
- _____. 2023. California Natural Diversity Database (CNDDDB) RareFind 5. <https://apps.wildlife.ca.gov>. Accessed 29 November 2023.
- California Native Plant Society, Rare Plant Program (CNPS). 2023. Inventory of Rare and Endangered Plants (online edition, v9.5). California Native Plant Society, Sacramento, CA. <http://www.rareplants.cnps.org>. Accessed 29 November 2023.
- Google. 2023. Google Earth Pro. Version 7.3.6.9345 (<https://www.google.com/earth/download/gep/agree.html>). Accessed 29 November 2023.
- Hermanson, J. W. and T. J. O'Shea. 1983. *Antrozous pallidus*. *American Society of Mammalogists. Mammalian Species* 213:1–8.



Messick, J. P. and M. G. Hornocker. 1981. Ecology of the badger in southwestern Idaho. *Wildlife Monographs* 76: 53pp.

Natural Resources Conservation Service (NRCS), U.S. Department of Agriculture. 2023. Web Soil Survey, National Cooperative Soil Survey: <http://websoilsurvey.nrcs.usda.gov/app/WebSoilSurvey.aspx>. Accessed 30 November 2023.

Poulin, R. G., L. D. Todd, E. A. Haug, B. A. Millsap, and M. S. Martell. 2020. Burrowing Owl (*Athene cunicularia*), version 1.0. *In* Birds of the World (A. F. Poole, Editor). Cornell Lab of Ornithology, Ithaca, NY, USA. <https://doi.org/10.2173/bow.buowl.01>.

Preston, R. E., M. S. Park, and L. Constance. 2012. *Eryngium spinosepalum*, in Jepson Flora Project (eds.) Jepson eFlora, http://ucjeps.berkeley.edu/eflora/eflora_display.php?tid=25099. Accessed 30 November 2023.

Quinn, J. 2015. American badgers (*Taxidea taxus*) in California. CDFW Conservation Lecture Series. <https://nrm.dfg.ca.gov/FileHandler.ashx?DocumentID=105752>. Accessed 30 November 2023.

Rosenberg, D. K., and Haley, K. L. 2004. The ecology of Burrowing Owls in the agroecosystem of the Imperial Valley, California. *Studies Avian Biol.* 27:120–135.

Shuford, W. D., and Gardali, T., editors. 2008. California Bird Species of Special Concern: A ranked assessment of species, subspecies, and distinct populations of birds of immediate conservation concern in California. *Studies of Western Birds* 1. Western Field Ornithologists, Camarillo, California, and California Department of Fish and Game, Sacramento.

Swainson's Hawk Technical Advisory Committee (SWTAC). 2000. Recommended Timing and Methodology for Swainson's Hawk Nesting Surveys in California's Central Valley. 5 pages.

Turner, C. E., Haynes, R. R., and Hellquist, C. B. 2012, *Sagittaria sanfordii*, in Jepson Flora Project (eds.) Jepson eFlora, https://ucjeps.berkeley.edu/eflora/eflora_display.php?tid=42633, accessed on December 05, 2023.



United States Army Corps of Engineers (USACE). 1987. Corps of Engineers Wetlands Delineation Manual. Wetland Research Program Technical Report Y-87-1.

_____. 2008. Regional Supplement to the Corps of Engineers Wetland Delineation Manual: Arid West Region (Version 2.0). ERDC/EL TR-08-28. https://www.nrcs.usda.gov/Internet/FSE_DOCUMENTS/stelprdb1046489.pdf. Accessed 22 November 2023.

U. S. Fish and Wildlife Service (USFWS). 2018. Migratory Bird Permit Memorandum: Destruction and Relocation of Migratory Bird Nest Contents. FWS/DMBM/AMB/O68029, 4 pages.

_____. 2023a. IPaC: Information for Planning and Conservation. <https://ecos.fws.gov/ipac/>. Accessed 30 November 2023.

_____. 2023b. National Wetlands Inventory website. U.S. Department of the Interior, Fish and Wildlife Service, Washington, D.C. <http://www.fws.gov/wetlands/>. Accessed 8 December 2023.

Williams, D. F. 1986. Mammalian species of special concern in California. California Department of Fish and Game, Sacramento. Administrative Report 86-1. 112pp.

Zeiner, D. C., W. F. Laudenslayer, Jr., K. E. Mayer, and M. White, eds. 1988-1990. California's Wildlife. Vol. I-III. California Department of Fish and Game, Sacramento, California.



Appendix A. USFWS list of threatened and endangered species.



United States Department of the Interior



FISH AND WILDLIFE SERVICE
Sacramento Fish And Wildlife Office
Federal Building
2800 Cottage Way, Room W-2605
Sacramento, CA 95825-1846
Phone: (916) 414-6600 Fax: (916) 414-6713

In Reply Refer To:
Project Code: 2024-0021167
Project Name: Dinuba Residential Development Project

November 30, 2023

Subject: List of threatened and endangered species that may occur in your proposed project location or may be affected by your proposed project

To Whom It May Concern:

The enclosed species list identifies threatened, endangered, proposed and candidate species, as well as proposed and final designated critical habitat, that may occur within the boundary of your proposed project and/or may be affected by your proposed project. The species list fulfills the requirements of the U.S. Fish and Wildlife Service (Service) under section 7(c) of the Endangered Species Act (Act) of 1973, as amended (16 U.S.C. 1531 *et seq.*).

New information based on updated surveys, changes in the abundance and distribution of species, changed habitat conditions, or other factors could change this list. Please feel free to contact us if you need more current information or assistance regarding the potential impacts to federally proposed, listed, and candidate species and federally designated and proposed critical habitat. Please note that under 50 CFR 402.12(e) of the regulations implementing section 7 of the Act, the accuracy of this species list should be verified after 90 days. This verification can be completed formally or informally as desired. The Service recommends that verification be completed by visiting the IPaC website at regular intervals during project planning and implementation for updates to species lists and information. An updated list may be requested through the IPaC system by completing the same process used to receive the enclosed list.

The purpose of the Act is to provide a means whereby threatened and endangered species and the ecosystems upon which they depend may be conserved. Under sections 7(a)(1) and 7(a)(2) of the Act and its implementing regulations (50 CFR 402 *et seq.*), Federal agencies are required to utilize their authorities to carry out programs for the conservation of threatened and endangered species and to determine whether projects may affect threatened and endangered species and/or designated critical habitat.

A Biological Assessment is required for construction projects (or other undertakings having similar physical impacts) that are major Federal actions significantly affecting the quality of the human environment as defined in the National Environmental Policy Act (42 U.S.C. 4332(2))

(c)). For projects other than major construction activities, the Service suggests that a biological evaluation similar to a Biological Assessment be prepared to determine whether the project may affect listed or proposed species and/or designated or proposed critical habitat. Recommended contents of a Biological Assessment are described at 50 CFR 402.12.

If a Federal agency determines, based on the Biological Assessment or biological evaluation, that listed species and/or designated critical habitat may be affected by the proposed project, the agency is required to consult with the Service pursuant to 50 CFR 402. In addition, the Service recommends that candidate species, proposed species and proposed critical habitat be addressed within the consultation. More information on the regulations and procedures for section 7 consultation, including the role of permit or license applicants, can be found in the "Endangered Species Consultation Handbook" at:

<https://www.fws.gov/sites/default/files/documents/endangered-species-consultation-handbook.pdf>

Migratory Birds: In addition to responsibilities to protect threatened and endangered species under the Endangered Species Act (ESA), there are additional responsibilities under the Migratory Bird Treaty Act (MBTA) and the Bald and Golden Eagle Protection Act (BGEPA) to protect native birds from project-related impacts. Any activity, intentional or unintentional, resulting in take of migratory birds, including eagles, is prohibited unless otherwise permitted by the U.S. Fish and Wildlife Service (50 C.F.R. Sec. 10.12 and 16 U.S.C. Sec. 668(a)). For more information regarding these Acts, see <https://www.fws.gov/program/migratory-bird-permit/what-we-do>.

The MBTA has no provision for allowing take of migratory birds that may be unintentionally killed or injured by otherwise lawful activities. It is the responsibility of the project proponent to comply with these Acts by identifying potential impacts to migratory birds and eagles within applicable NEPA documents (when there is a federal nexus) or a Bird/Eagle Conservation Plan (when there is no federal nexus). Proponents should implement conservation measures to avoid or minimize the production of project-related stressors or minimize the exposure of birds and their resources to the project-related stressors. For more information on avian stressors and recommended conservation measures, see <https://www.fws.gov/library/collections/threats-birds>.

In addition to MBTA and BGEPA, Executive Order 13186: *Responsibilities of Federal Agencies to Protect Migratory Birds*, obligates all Federal agencies that engage in or authorize activities that might affect migratory birds, to minimize those effects and encourage conservation measures that will improve bird populations. Executive Order 13186 provides for the protection of both migratory birds and migratory bird habitat. For information regarding the implementation of Executive Order 13186, please visit <https://www.fws.gov/partner/council-conservation-migratory-birds>.

We appreciate your concern for threatened and endangered species. The Service encourages Federal agencies to include conservation of threatened and endangered species into their project planning to further the purposes of the Act. Please include the Consultation Code in the header of this letter with any request for consultation or correspondence about your project that you submit to our office.

Attachment(s):

- Official Species List

OFFICIAL SPECIES LIST

This list is provided pursuant to Section 7 of the Endangered Species Act, and fulfills the requirement for Federal agencies to "request of the Secretary of the Interior information whether any species which is listed or proposed to be listed may be present in the area of a proposed action".

This species list is provided by:

Sacramento Fish And Wildlife Office

Federal Building
2800 Cottage Way, Room W-2605
Sacramento, CA 95825-1846
(916) 414-6600

PROJECT SUMMARY

Project Code: 2024-0021167

Project Name: Dinuba Residential Development Project

Project Type: Residential Construction

Project Description: The Project will involve constructing a 76-unit residential development on approximately 18.59 acres comprising Assessor Parcel Number 012-290-011. The Project will underground Horsman Ditch on the site's eastern border. The Project site, which currently supports an irrigated hayfield and a rural residence, is bounded by Road 70 to the west, an orchard to the north, Road 72 to the east, and West Sierra Way to the south.

Project Location:

The approximate location of the project can be viewed in Google Maps: <https://www.google.com/maps/@36.5398029,-119.41507331301011,14z>



Counties: Tulare County, California

ENDANGERED SPECIES ACT SPECIES

There is a total of 9 threatened, endangered, or candidate species on this species list.

Species on this list should be considered in an effects analysis for your project and could include species that exist in another geographic area. For example, certain fish may appear on the species list because a project could affect downstream species.

IPaC does not display listed species or critical habitats under the sole jurisdiction of NOAA Fisheries¹, as USFWS does not have the authority to speak on behalf of NOAA and the Department of Commerce.

See the "Critical habitats" section below for those critical habitats that lie wholly or partially within your project area under this office's jurisdiction. Please contact the designated FWS office if you have questions.

-
1. [NOAA Fisheries](#), also known as the National Marine Fisheries Service (NMFS), is an office of the National Oceanic and Atmospheric Administration within the Department of Commerce.

MAMMALS

NAME	STATUS
Fresno Kangaroo Rat <i>Dipodomys nitratooides exilis</i> There is final critical habitat for this species. Your location does not overlap the critical habitat. Species profile: https://ecos.fws.gov/ecp/species/5150	Endangered
San Joaquin Kit Fox <i>Vulpes macrotis mutica</i> No critical habitat has been designated for this species. Species profile: https://ecos.fws.gov/ecp/species/2873	Endangered

BIRDS

NAME	STATUS
California Condor <i>Gymnogyps californianus</i> Population: U.S.A. only, except where listed as an experimental population There is final critical habitat for this species. Your location does not overlap the critical habitat. Species profile: https://ecos.fws.gov/ecp/species/8193	Endangered

REPTILES

NAME	STATUS
Northwestern Pond Turtle <i>Actinemys marmorata</i> No critical habitat has been designated for this species. Species profile: https://ecos.fws.gov/ecp/species/1111	Proposed Threatened

AMPHIBIANS

NAME	STATUS
California Tiger Salamander <i>Ambystoma californiense</i> Population: U.S.A. (Central CA DPS) There is final critical habitat for this species. Your location does not overlap the critical habitat. Species profile: https://ecos.fws.gov/ecp/species/2076	Threatened

INSECTS

NAME	STATUS
Monarch Butterfly <i>Danaus plexippus</i> No critical habitat has been designated for this species. Species profile: https://ecos.fws.gov/ecp/species/9743	Candidate

CRUSTACEANS

NAME	STATUS
Vernal Pool Fairy Shrimp <i>Branchinecta lynchi</i> There is final critical habitat for this species. Your location does not overlap the critical habitat. Species profile: https://ecos.fws.gov/ecp/species/498	Threatened

FLOWERING PLANTS

NAME	STATUS
San Joaquin Adobe Sunburst <i>Pseudobahia peirsonii</i> No critical habitat has been designated for this species. Species profile: https://ecos.fws.gov/ecp/species/2931	Threatened
San Joaquin Valley Orcutt Grass <i>Orcuttia inaequalis</i> There is final critical habitat for this species. Your location does not overlap the critical habitat. Species profile: https://ecos.fws.gov/ecp/species/5506	Threatened

CRITICAL HABITATS

THERE ARE NO CRITICAL HABITATS WITHIN YOUR PROJECT AREA UNDER THIS OFFICE'S JURISDICTION.

YOU ARE STILL REQUIRED TO DETERMINE IF YOUR PROJECT(S) MAY HAVE EFFECTS ON ALL ABOVE LISTED SPECIES.

IPAC USER CONTACT INFORMATION

Agency: Private Entity
Name: Norman Sisk
Address: 9493 N Ft Washington Rd
Address Line 2: Ste 108
City: Fresno
State: CA
Zip: 93730
Email: rsisk@colibri-ecology.com
Phone: 5596816810



Appendix B. CNDDDB occurrence records.



Selected Elements by Scientific Name

California Department of Fish and Wildlife

California Natural Diversity Database



Query Criteria: Quad (Reedley) OR Traver (3611944) OR Burris Park (3611945) OR Selma (3611955) OR Sanger (3611965) OR Wahtoke (3611964) OR Orange Cove North (3611963) OR Orange Cove South (3611953) OR Monson (3611943)

Species	Element Code	Federal Status	State Status	Global Rank	State Rank	Rare Plant Rank/CDFW SSC or FP
Ambystoma californiense pop. 1 California tiger salamander - central California DPS	AAAAA01181	Threatened	Threatened	G2G3T3	S3	WL
Antrozous pallidus pallid bat	AMACC10010	None	None	G4	S3	SSC
Athene cunicularia burrowing owl	ABNSB10010	None	None	G4	S2	SSC
Atriplex cordulata var. erecticaulis Earlimart orache	PDCHE042V0	None	None	G3T1	S1	1B.2
Atriplex depressa brittlescale	PDCHE042L0	None	None	G2	S2	1B.2
Atriplex minuscula lesser saltscale	PDCHE042M0	None	None	G2	S2	1B.1
Bombus crotchii Crotch bumble bee	IIHYM24480	None	Candidate Endangered	G2	S2	
Bombus morrisoni Morrison bumble bee	IIHYM24460	None	None	G3	S1S2	
Bombus pensylvanicus American bumble bee	IIHYM24260	None	None	G3G4	S2	
Branchinecta lynchi vernal pool fairy shrimp	ICBRA03030	Threatened	None	G3	S3	
Branchinecta mesoovallensis midvalley fairy shrimp	ICBRA03150	None	None	G2	S2S3	
Buteo swainsoni Swainson's hawk	ABNKC19070	None	Threatened	G5	S4	
Carex comosa bristly sedge	PMCYP032Y0	None	None	G5	S2	2B.1
Coccyzus americanus occidentalis western yellow-billed cuckoo	ABNRB02022	Threatened	Endangered	G5T2T3	S1	
Delphinium recurvatum recurved larkspur	PDRAN0B1J0	None	None	G2?	S2?	1B.2
Desmocerus californicus dimorphus valley elderberry longhorn beetle	IICOL48011	Threatened	None	G3T3	S3	
Emys marmorata western pond turtle	ARAAD02030	Proposed Threatened	None	G3G4	S3	SSC
Eryngium spinosepalum spiny-sepaled button-celery	PDAP10Z0Y0	None	None	G2	S2	1B.2



Selected Elements by Scientific Name
California Department of Fish and Wildlife
California Natural Diversity Database



Species	Element Code	Federal Status	State Status	Global Rank	State Rank	Rare Plant Rank/CDFW SSC or FP
<i>Eumops perotis californicus</i> western mastiff bat	AMACD02011	None	None	G4G5T4	S3S4	SSC
<i>Euphorbia hooveri</i> Hoover's spurge	PDEUP0D150	Threatened	None	G1	S1	1B.2
Great Valley Mixed Riparian Forest Great Valley Mixed Riparian Forest	CTT61420CA	None	None	G2	S2.2	
<i>Helianthus winteri</i> Winter's sunflower	PDAST4N260	None	None	G2?	S2?	1B.2
<i>Imperata brevifolia</i> California satintail	PMPOA3D020	None	None	G3	S3	2B.1
<i>Lanius ludovicianus</i> loggerhead shrike	ABPBR01030	None	None	G4	S4	SSC
<i>Lasiurus cinereus</i> hoary bat	AMACC05032	None	None	G3G4	S4	
<i>Lasthenia chrysantha</i> alkali-sink goldfields	PDAST5L030	None	None	G2	S2	1B.1
<i>Lasthenia glabrata ssp. coulteri</i> Coulter's goldfields	PDAST5L0A1	None	None	G4T2	S2	1B.1
<i>Lepidurus packardi</i> vernal pool tadpole shrimp	ICBRA10010	Endangered	None	G3	S3	
<i>Linderiella occidentalis</i> California linderiella	ICBRA06010	None	None	G2G3	S2S3	
<i>Lithobates pipiens</i> northern leopard frog	AAABH01170	None	None	G5	S2	SSC
<i>Lytta molesta</i> molestan blister beetle	IICOL4C030	None	None	G2	S2	
Northern Claypan Vernal Pool Northern Claypan Vernal Pool	CTT44120CA	None	None	G1	S1.1	
Northern Hardpan Vernal Pool Northern Hardpan Vernal Pool	CTT44110CA	None	None	G3	S3.1	
<i>Orcuttia inaequalis</i> San Joaquin Valley Orcutt grass	PMPOA4G060	Threatened	Endangered	G1	S1	1B.1
<i>Pseudobahia peirsonii</i> San Joaquin adobe sunburst	PDAST7P030	Threatened	Endangered	G1	S1	1B.1
<i>Puccinellia simplex</i> California alkali grass	PMPOA53110	None	None	G2	S2	1B.2
<i>Rana boylli pop. 5</i> foothill yellow-legged frog - south Sierra DPS	AAABH01055	Endangered	Endangered	G3T2	S2	
<i>Sagittaria sanfordii</i> Sanford's arrowhead	PMALI040Q0	None	None	G3	S3	1B.2
<i>Spea hammondi</i> western spadefoot	AAABF02020	None	None	G2G3	S3S4	SSC



Selected Elements by Scientific Name
California Department of Fish and Wildlife
California Natural Diversity Database



Species	Element Code	Federal Status	State Status	Global Rank	State Rank	Rare Plant Rank/CDFW SSC or FP
<i>Talanites moodyae</i> Moody's gnaphosid spider	ILARA98020	None	None	G2G3	S2S3	
<i>Tuctoria greenei</i> Greene's tuctoria	PMPOA6N010	Endangered	Rare	G1	S1	1B.1
<i>Valley Sacaton Grassland</i> Valley Sacaton Grassland	CTT42120CA	None	None	G1	S1.1	
<i>Vulpes macrotis mutica</i> San Joaquin kit fox	AMAJA03041	Endangered	Threatened	G4T2	S3	

Record Count: 43



Appendix C. CNPS plant list.







CNPS Rare Plant Inventory

Search Results

23 matches found. Click on scientific name for details

Search Criteria: 9-Quad include [3611963:3611964:3611965:3611943:3611953:3611945:3611954:3611944:3611955]

▲ SCIENTIFIC NAME	COMMON NAME	FAMILY	LIFEFORM	BLOOMING PERIOD	FED LIST	STATE LIST	GLOBAL RANK	STATE RANK	PLANT RANK	CA ENDEMIC	DATE ADDED	PHOTO
<u><i>Amaranthus watsonii</i></u>	Watson's amaranth	Amaranthaceae	annual herb	Apr-Sep	None	None	G5?	S3	4.3		2001-01-01	 © 2003 Debra Valov
<u><i>Atriplex cordulata</i> var. <i>cordulata</i></u>	heartscale	Chenopodiaceae	annual herb	Apr-Oct	None	None	G3T2	S2	1B.2	Yes	1988-01-01	 © 1994 Robert E. Preston, Ph.D.
<u><i>Atriplex cordulata</i> var. <i>erecticaulis</i></u>	Earlimart orache	Chenopodiaceae	annual herb	Aug-Sep(Nov)	None	None	G3T1	S1	1B.2	Yes	2001-01-01	 © 2009 Robert E. Preston, Ph.D.
<u><i>Atriplex depressa</i></u>	brittlescale	Chenopodiaceae	annual herb	Apr-Oct	None	None	G2	S2	1B.2	Yes	1994-01-01	 © 2009 Zoya Akulova
<u><i>Atriplex minuscula</i></u>	lesser saltscale	Chenopodiaceae	annual herb	May-Oct	None	None	G2	S2	1B.1	Yes	1994-01-01	 © 2000 Robert E. Preston, Ph.D.

<u><i>Atriplex subtilis</i></u>	subtle orache	Chenopodiaceae	annual herb	(Apr)Jun-Sep(Oct)	None	None	G1	S1	1B.2	Yes	1994-01-01	 © 2000 Robert E. Preston, Ph.D.
<u><i>Carex comosa</i></u>	bristly sedge	Cyperaceae	perennial rhizomatous herb	May-Sep	None	None	G5	S2	2B.1		1994-01-01	 Dean Wm. Taylor 1997
<u><i>Convolvulus simulans</i></u>	small-flowered morning-glory	Convolvulaceae	annual herb	Mar-Jul	None	None	G4	S4	4.2		1994-01-01	No Photo Available
<u><i>Delphinium hansenii ssp. ewanianum</i></u>	Ewan's larkspur	Ranunculaceae	perennial herb	Mar-May	None	None	G4T3	S3	4.2	Yes	1994-01-01	No Photo Available
<u><i>Delphinium recurvatum</i></u>	recurved larkspur	Ranunculaceae	perennial herb	Mar-Jun	None	None	G2?	S2?	1B.2	Yes	1988-01-01	No Photo Available
<u><i>Eryngium spinosepalum</i></u>	spiny-sepaled button-celery	Apiaceae	annual/perennial herb	Apr-Jun	None	None	G2	S2	1B.2	Yes	1980-01-01	No Photo Available
<u><i>Erythranthe acutidens</i></u>	Kings River monkeyflower	Phrymaceae	annual herb	Apr-Jul	None	None	G2G3	S2S3	3	Yes	1974-01-01	 Barry Breckling
<u><i>Euphorbia hooveri</i></u>	Hoover's spurge	Euphorbiaceae	annual herb	Jul-Sep(Oct)	FT	None	G1	S1	1B.2	Yes	1974-01-01	No Photo Available
<u><i>Helianthus winteri</i></u>	Winter's sunflower	Asteraceae	perennial shrub	Jan-Dec	None	None	G2?	S2?	1B.2	Yes	2014-10-15	 © 2014 Chris Winchell
<u><i>Hordeum intercedens</i></u>	vernal barley	Poaceae	annual herb	Mar-Jun	None	None	G3G4	S3S4	3.2		1994-01-01	No Photo Available
<u><i>Imperata brevifolia</i></u>	California satintail	Poaceae	perennial rhizomatous herb	Sep-May	None	None	G3	S3	2B.1		2006-12-26	 © 2020 Matt C. Berger

<u><i>Lasthenia chrysantha</i></u>	alkali-sink goldfields	Asteraceae	annual herb	Feb-Apr	None	None	G2	S2	1B.1	Yes	2019-09-30	 © 2009 California State University, Stanislaus
<u><i>Lasthenia glabrata</i> ssp. <i>coulteri</i></u>	Coulter's goldfields	Asteraceae	annual herb	Feb-Jun	None	None	G4T2	S2	1B.1		1994-01-01	 © 2013 Keir Morse
<u><i>Orcuttia inaequalis</i></u>	San Joaquin Valley Orcutt grass	Poaceae	annual herb	Apr-Sep	FT	CE	G1	S1	1B.1	Yes	1974-01-01	No Photo Available
<u><i>Pseudobahia peirsonii</i></u>	San Joaquin adobe sunburst	Asteraceae	annual herb	Feb-Apr	FT	CE	G1	S1	1B.1	Yes	1974-01-01	No Photo Available
<u><i>Puccinellia simplex</i></u>	California alkali grass	Poaceae	annual herb	Mar-May	None	None	G2	S2	1B.2		2015-10-15	No Photo Available
<u><i>Sagittaria sanfordii</i></u>	Sanford's arrowhead	Alismataceae	perennial rhizomatous herb (emergent)	May- Oct(Nov)	None	None	G3	S3	1B.2	Yes	1984-01-01	 ©2013 Debra L. Cook
<u><i>Tuctoria greenei</i></u>	Greene's tuctoria	Poaceae	annual herb	May- Jul(Sep)	FE	CR	G1	S1	1B.1	Yes	1974-01-01	 ©2008 F. Gauna

Showing 1 to 23 of 23 entries

Suggested Citation:

California Native Plant Society, Rare Plant Program. 2023. Rare Plant Inventory (online edition, v9.5). Website <https://www.rareplants.cnps.org> [accessed 29 November 2023].



Appendix D. Recommended timing and methodology for Swainson's hawk nesting surveys in California's Central Valley.

RECOMMENDED TIMING AND METHODOLOGY FOR SWAINSON'S HAWK NESTING SURVEYS IN CALIFORNIA'S CENTRAL VALLEY

**Swainson's Hawk Technical Advisory Committee
May 31, 2000**

This set of survey recommendations was developed by the Swainson's Hawk Technical Advisory Committee (TAC) to maximize the potential for locating nesting Swainson's hawks, and thus reducing the potential for nest failures as a result of project activities/disturbances. The combination of appropriate surveys, risk analysis, and monitoring has been determined to be very effective in reducing the potential for project-induced nest failures. As with most species, when the surveyor is in the right place at the right time, Swainson's hawks may be easy to observe; but some nest sites may be very difficult to locate, and even the most experienced surveyors have missed nests, nesting pairs, mis-identified a hawk in a nest, or believed incorrectly that a nest had failed. There is no substitute for specific Swainson's hawk survey experience and acquiring the correct search image.

METHODOLOGY

Surveys should be conducted in a manner that maximizes the potential to observe the adult Swainson's hawks, as well as the nest/chicks second. To meet the California Department of Fish and Game's (CDFG) recommendations for mitigation and protection of Swainson's hawks, surveys should be conducted for a ½ mile radius around all project activities, and if active nesting is identified within the ½ mile radius, consultation is required. In general, the TAC recommends this approach as well.

Minimum Equipment

Minimum survey equipment includes a high-quality pair of binoculars and a high quality spotting scope. Surveying even the smallest project area will take hours, and poor optics often result in eye-strain and difficulty distinguishing details in vegetation and subject birds. Other equipment includes good maps, GPS units, flagging, and notebooks.

Walking vs Driving

Driving (car or boat) or "windshield surveys" are usually preferred to walking if an adequate roadway is available through or around the project site. While driving, the observer can typically approach much closer to a hawk without causing it to fly. Although it might appear that a flying bird is more visible, they often fly away from the observer using trees as screens; and it is difficult to determine from where a flying bird came. Walking surveys are useful in locating a nest after a nest territory is identified, or when driving is not an option.

Angle and Distance to the Tree

Surveying subject trees from multiple angles will greatly increase the observer's chance of detecting a nest or hawk, especially after trees are fully leafed and when surveying multiple trees

in close proximity. When surveying from an access road, survey in both directions. Maintaining a distance of 50 meters to 200 meters from subject trees is optimal for observing perched and flying hawks without greatly reducing the chance of detecting a nest/young: Once a nesting territory is identified, a closer inspection may be required to locate the nest.

Speed

Travel at a speed that allows for a thorough inspection of a potential nest site. Survey speeds should not exceed 5 miles per hour to the greatest extent possible. If the surveyor must travel faster than 5 miles per hour, stop frequently to scan subject trees.

Visual and Aural Ques

Surveys will be focused on both observations and vocalizations. Observations of nests, perched adults, displaying adults, and chicks during the nesting season are all indicators of nesting Swainson's hawks. In addition, vocalizations are extremely helpful in locating nesting territories. Vocal communication between hawks is frequent during territorial displays; during courtship and mating; through the nesting period as mates notify each other that food is available or that a threat exists; and as older chicks and fledglings beg for food.

Distractions

Minimize distractions while surveying. Although two pairs of eyes may be better than one pair at times, conversation may limit focus. Radios should be off, not only are they distracting, they may cover a hawk's call.

Notes and Species Observed

Take thorough field notes. Detailed notes and maps of the location of observed Swainson's hawk nests are essential for filling gaps in the Natural Diversity Data Base; please report all observed nest sites. Also document the occurrence of nesting great homed owls, red-tailed hawks, red-shouldered hawks and other potentially competitive species. These species will infrequently nest within 100 yards of each other, so the presence of one species will not necessarily exclude another.

TIMING

To meet **the minimum level** of protection for the species, surveys should be completed for **at least** the two survey periods immediately prior to a project's initiation. For example, if a project is scheduled to begin on June 20, you should complete 3 surveys in Period III and 3 surveys in Period V. However, it is always recommended that surveys be completed in Periods II, III and V. **Surveys should not be conducted in Period IV.**

The survey periods are defined by the timing of migration, courtship, and nesting in a "typical" year for the majority of Swainson's hawks from San Joaquin County to Northern Yolo County. Dates should be adjusted in consideration of early and late nesting seasons, and geographic differences (northern nesters tend to nest slightly later, etc). If you are not sure, contact a TAC member or CDFG biologist.

Survey dates Justification and search image	Survey time	Number of Surveys
--	-------------	-------------------

I. <i>January-March 20 (recommended optional)</i>	<i>All day</i>	<i>1</i>
---	----------------	----------

Prior to Swainson’s hawks returning, it may be helpful to survey the project site to determine potential nest locations. Most nests are easily observed from relatively long distances, giving the surveyor the opportunity to identify potential nest sites, as well as becoming familiar with the project area. It also gives the surveyor the opportunity to locate and map competing species nest sites such as great homed owls from February on, and red-tailed hawks from March on. After March 1, surveyors are likely to observe Swainson’s hawks staging in traditional nest territories.

II. <i>March 20 to April 5</i>	<i>Sunrise to 1000 1600 to sunset</i>	<i>3</i>
--------------------------------	---	----------

Most Central Valley Swainson’s hawks return by April 1, and immediately begin occupying their traditional nest territories. For those few that do not return by April 1, there are often hawks (“floaters”) that act as place-holders in traditional nest sites; they are birds that do not have mates, but temporarily attach themselves to traditional territories and/or one of the site’s “owners.” Floaters are usually displaced by the territories’ owner(s) if the owner returns.

Most trees are leafless and are relatively transparent; it is easy to observe old nests, staging birds, and competing species. The hawks are usually in their territories during the survey hours, but typically soaring and foraging in the mid-day hours. Swainson’s hawks may often be observed involved in territorial and courtship displays, and circling the nest territory. Potential nest sites identified by the observation of staging Swainson’s hawks will usually be active territories during that season, although the pair may not successfully nest/reproduce that year.

III. <i>April 5 to April 20</i>	<i>Sunrise to 1200 1630 to Sunset</i>	<i>3</i>
---------------------------------	---	----------

Although trees are much less transparent at this time, ‘activity at the nest site increases significantly. Both males and females are actively nest building, visiting their selected site frequently. Territorial and courtship displays are increased, as is copulation. The birds tend to vocalize often, and nest locations are most easily identified. This period may require a great deal of “sit and watch” surveying.

IV. <i>April 21 to June 10</i>	<i>Monitoring known nest sites only Initiating Surveys is not recommended</i>	
--------------------------------	--	--

Nests are extremely difficult to locate this time of year, and even the most experienced surveyor will miss them, especially if the previous surveys have not been done. During this phase of nesting, the female Swainson’s hawk is in brood position, very low in the nest, laying eggs, incubating, or protecting the newly hatched and vulnerable chicks; her head may or may not be visible. Nests are often well-hidden, built into heavily vegetated sections of trees or in clumps of mistletoe, making them all but invisible. Trees are usually not viewable from all angles, which may make nest observation impossible.

Following the male to the nest may be the only method to locate it, and the male will spend hours away from the nest foraging, soaring, and will generally avoid drawing attention to the nest site. Even if the observer is fortunate enough to see a male returning with food for the female, if the female determines it is not safe she will not call the male in, and he will not approach the nest; this may happen if the observer, or others, are too close to the nest or if other threats, such as rival hawks, are apparent to the female or male.

V. June 10 to July 30 (post-fledging)





Sunrise to 1200

3

1600 to sunset

Young are active and visible, and relatively safe without parental protection. Both adults make numerous trips to the nest and are often soaring above, or perched near or on the nest tree. The location and construction of the nest may still limit visibility of the nest, young, and adults.

**DETERMINING A PROJECT'S POTENTIAL
FOR IMPACTING SWAINSON'S HAWKS**

LEVEL OF RISK	REPRODUCTIVE SUCCESS (Individuals)	LONGTERM SURVIVABILITY (Population)	NORMAL SITE CHARACTERISTICS (Daily Average)	NEST MONITORING
<p align="center">HIGH</p>   <p align="center">LOW</p>	<p>Direct physical contact with the nest tree while the birds are on eggs or protecting young. (Helicopters in close proximity)</p> <p>Loss of nest tree after nest building is begun prior to laying eggs.</p> <p>Personnel within 50 yards of nest tree (out of vehicles) for extended periods while birds are on eggs or protecting young that are < 10 days old.</p> <p>Initiating construction activities (machinery and personnel) within 200 yards of the nest after eggs are laid and before young are > 10 days old.</p> <p>Heavy machinery only working within 50 yards of nest.</p> <p>Initiating construction activities within 200 yards of nest before nest building begins or after young > 10 days old.</p> <p>All project activities (personnel and machinery) greater than 200 yards from nest.</p>	<p>Loss of available foraging area.</p> <p>Loss of nest trees.</p> <p>Loss of potential nest trees.</p> <p>Cumulative: Multi-year, multi-site projects with substantial noise/personnel disturbance.</p> <p>Cumulative: Single-season projects with substantial noise/personnel disturbance that is greater than or significantly different from the daily norm.</p> <p>Cumulative: Single-season projects with activities that “blend” well with site’s “normal” activities.</p>	<p>Little human-created noise, little human use: nest is well away from dwellings, equipment yards, human access areas, etc. <i>Do not include general cultivation practices in evaluation.</i></p> <p>Substantial human-created noise and occurrence: nest is near roadways, well-used waterways, active airstrips, areas that have high human use. <i>Do not include general cultivation practices in evaluation.</i></p>	<p align="center">MORE</p>   <p align="center">LESS</p>



Appendix E. Staff report regarding mitigation for impacts to Swainson's hawk (*Buteo swainsoni*) in the Central Valley of California.

Memorandum

To : Div. Chiefs - IFD, BDD, NHD, WMD
Reg. Mgrs. - Regions 1, 2, 3, 4

Date : November 8, 1994

From : Department of Fish and Game

Subject: Staff Report Regarding Mitigation for Impacts to Swainson's Hawks
(*Buteo swainsoni*) in the Central Valley of California

I am hereby transmitting the Staff Report Regarding Mitigation for Impacts to Swainson's Hawks in the Central Valley of California for your use in reviewing projects (California Environmental Quality Act [CEQA] and others) and in developing 2081 Management Authorizations and 2090 Biological Opinions which may affect Swainson's hawk habitat in the Central Valley. The staff report has been developed during the last 18 months by the Environmental Services Division (ESD) in cooperation with the Wildlife Management Division (WMD) and Regions 1, 2, and 4. It has been sent out for public review on several occasions and redrafted as appropriate.

Either the mitigation measures in the staff report may be used or project specific measures may be developed. Alternative project specific mitigation measures proposed by the Department Divisions/Regions or by project sponsors will also be considered. However, such mitigation measures must be submitted to ESD for review. The review process will focus on the consistency of the proposed measure with Department, Fish and Game Commission, and legislative policy and with laws regarding raptors and listed species. ESD will coordinate project specific mitigation measure review with WMD.

If you have any questions regarding the report, please contact Mr. Ron Rempel, Program Supervisor, Habitat Conservation Planning and Endangered Species Permitting, Environmental Services Division at (916) 654-9980.

COPY Original signed by
A. Petrovich, Jr.

For
Boyd Gibbons
Direction

Enclosure

cc: Mr. Ron Rempel
Department of Fish and Game
Sacramento

file; d, exfile, esd, chron
Vouchilas/seh/pdl SRPBUTEO.DS1

**Staff Report regarding Mitigation
for Impacts to Swainson's Hawks (*Buteo swainsoni*)
in the Central Valley of California**

INTRODUCTION

The Legislature and the Fish and Game Commission have developed the policies, standards and regulatory mandates which, if implemented, are intended to help stabilize and reverse dramatic population declines of threatened and endangered species. In order to determine how the Department of Fish and Game (Department) could judge the adequacy of mitigation measures designed to offset impacts to Swainson's hawks in the Central Valley, Staff (WMD, ESD and Regions) has prepared this report. To ensure compliance with legislative and Commission policy, mitigation requirements which are consistent with this report should be incorporated into: (1) Department comments to Lead Agencies and project sponsors pursuant to the California Environmental Quality Act (CEQA); (2) Fish and Game Code Section 2081 Management Authorizations (Management Authorizations); and (3) Fish and Game Code Section 2090 Consultations with State CEQA Lead Agencies.

The report is designed to provide the Department (including regional offices and divisions), CEQA Lead Agencies and project proponents the context in which the Environmental Services Division (ESD) will review proposed project specific mitigation measures. This report also includes "model" mitigation measures which have been judged to be consistent with policies, standards and legal mandates of the Legislature and Fish and Game Commission. Alternative mitigation measures, tailored to specific projects, may be developed if consistent with this report. Implementation of mitigation measures consistent with this report are intended to help achieve the conservation goals for the Swainson's hawk and should complement multi-species habitat conservation planning efforts currently underway.

The Department is preparing a recovery plan for the species and it is anticipated that this report will be revised to incorporate recovery plan goals. It is anticipated that the recovery plan will be completed by the end of 1995. The Swainson's hawk recovery plan will establish criteria for species recovery through preservation of existing habitat, population expansion into former habitat, recruitment of young into the population, and other specific recovery efforts.

During project review the Department should consider whether a proposed project will adversely affect suitable foraging habitat within a ten (10) mile radius of an active (used during one or more of the last 5 years) Swainson's hawk nest(s). Suitable Swainson's hawk foraging habitat will be those habitats and crops identified in Bechard (1983), Bloom (1980), and Estep (1989). The following vegetation types/agricultural crops are considered small mammal and insect foraging habitat for Swainson's hawks:

- alfalfa
- fallow fields
- beet, tomato, and other low-growing row or field crops
- dry-land and irrigated pasture

- rice land (when not flooded)
- cereal grain crops (including corn after harvest)

The ten mile radius standard is the flight distance between active (and successful) nest sites and suitable foraging habitats, as documented in telemetry studies (Estep 1989, Babcock 1993). Based on the ten mile radius, new development projects which adversely modify nesting and/or foraging habitat should mitigate the project's impacts to the species. The ten mile foraging radius recognizes a need to strike a balance between the biological needs of reproducing pairs (including eggs and nestlings) and the economic benefit of developments) consistent with Fish and Game Code Section 2053.

Since over 95% of Swainson's hawk nests occur on private land, the Department's mitigation program should include incentives that preserve agricultural lands used for the production of crops, which are compatible with Swainson's hawk foraging needs, while providing an opportunity for urban development and other changes in land use adjacent to existing urban areas.

LEGAL STATUS

Federal

The Swainson's hawk is a migratory bird species protected under the Migratory Bird Treaty Act (MBTA) of 1918 (16 U.S.C. 703-711). The MBTA makes it unlawful to take, possess, buy, sell, purchase, or barter any migratory bird listed in Section 50 of the Code of Federal Regulations (C.F.R.) Part 10, including feathers or other parts, nests, eggs or products, except as allowed by implementing regulations (50 C.F.R. 21).

State

The Swainson's hawk has been listed as a threatened species by the California Fish and Game Commission pursuant to the California Endangered Species Act (CESA), see Title 14, California Code of Regulations, Section 670.5(b)(5)(A).

LEGISLATIVE AND COMMISSION POLICIES, LEGAL MANDATES AND STANDARDS

The FGC policy for threatened species is, in part, to: "Protect and preserve all native species ... and their habitats...." This policy also directs the Department to work with all interested persons to protect and preserve sensitive resources and their habitats. Consistent with this policy and direction, the Department is enjoined to implement measures that assure protection for the Swainson's hawk.

The California State Legislature, when enacting the provisions of CESA, made the following findings and declarations in Fish and Game Code Section 2051:

- a) "Certain species of fish, wildlife, and plants have been rendered extinct as a consequence of man's activities, untempered by adequate concern and conservation";
- b) "Other species of fish, wildlife, and plants are in danger of, or threatened with, extinction because their habitats are threatened with destruction, adverse modification, or severe curtailment because of overexploitation, disease, predation, or other factors (emphasis added);and
- c) "These species of fish, wildlife, and plants are of ecological, educational, historical, recreational, esthetic, economic, and scientific value to the people of this state, and the conservation, protection, and enhancement of these species and their habitat is of statewide concern" (emphasis added).

The Legislature also proclaimed that it "is the policy of the state to conserve, protect, restore, and enhance any endangered or threatened species and its habitat and that it is the intent of the Legislature, consistent with conserving the species, to acquire lands for habitat for these species" (emphasis added).

Section 2053 of the Fish and Game Code states, in part, "it is the policy of the state that state agencies should not approve projects as proposed which would jeopardize the continued existence of any endangered or threatened species or result in the destruction or adverse modification of habitat essential to the continued existence of those species, if there are reasonable and prudent alternatives available consistent with conserving the species and or its habitat which would prevent jeopardy" (emphasis added).

Section 2054 states "The Legislature further finds and declares that, in the event specific economic, social, and or other conditions make infeasible such alternatives, individual projects may be approved if appropriate mitigation and enhancement measures are provided" (emphasis added).

Loss or alteration of foraging habitat or nest site disturbance which results in:

(1) nest abandonment; (2) loss of young; (3) reduced health and vigor of eggs and/or nestlings (resulting in reduced survival rates), may ultimately result in the take (killing) of nestling or fledgling Swainson's hawks incidental to otherwise lawful activities. The taking of Swainson's hawks in this manner can be, a violation of Section 2080 of the Fish and Game Code. This interpretation of take has been judicially affirmed by the landmark appellate court decision pertaining to CESA (DFG v. ACID, 8 CA App.4, 41554). The essence of the decision emphasized that the intent and purpose of CESA applies to all activities that take or kill endangered or threatened species, even when the taking is incidental to otherwise legal activities. To avoid potential violations of Fish and Game Code Section 2080, the Department recommends and encourages project sponsors to obtain 2081 Management Authorizations for their projects.

Although this report has been prepared to assist the Department in working with the development community, the prohibition against take (Fish and Game Code Section 2080) applies to all persons, including those engaged in agricultural activities and routine maintenance of facilities. In addition, sections 3503, 3503.5, and 3800 of the Fish and Game Code prohibit the take, possession, or destruction of birds, their nests or eggs.

To avoid potential violation of Fish and Game Code Section 2080 (i.e. killing of a listed species), project-related disturbance at active Swainson's hawk nesting sites should be reduced or eliminated during critical phases of the nesting cycle (March 1 - September 15 annually). Delineation of specific activities which could cause nest abandonment (take) of Swainson's hawk during the nesting period should be done on a case-by-case basis.

CEQA requires a mandatory findings of significance if a project's impacts to threatened or endangered species are likely to occur (Sections 21001 (c), 21083, Guidelines Sections 15380, 15064, 15065). Impacts must be avoided or mitigated to less than significant levels unless the CEQA Lead Agency makes and supports findings of Overriding Consideration. The CEQA Lead Agency's Findings of Overriding Consideration does not eliminate the project sponsor's obligation to comply with Fish and Game Code Section 2080.

NATURAL HISTORY

The Swainson's hawk (*Buteo swainsoni*) is a large, broad winged buteo which frequents open country. They are about the same size as a red-tailed hawk (*Buteo jamaicensis*), but trimmer, weighing approximately 800-1100 grams (1.75 - 2 lbs). They have about a 125 cm. (4+foot) wingspan. The basic body plumage may be highly variable and is characterized by several color morphs - light, dark, and rufous. In dark phase birds, the entire body of the bird may be sooty black. Adult birds generally have dark backs. The ventral or underneath sections may be light with a characteristic dark, wide "bib" from the lower throat down to the upper breast, light colored wing linings and pointed wing tips. The tail is gray ventrally with a subterminal dusky band, and narrow, less conspicuous barring proximally. The sexes are similar in appearance; females however, are slightly larger and heavier than males, as is the case in most sexually dimorphic raptors. There are no recognized subspecies (Palmer 1988).

The Swainson's hawk is a long distance migrator. The nesting grounds occur in northwestern Canada, the western U.S., and Mexico and most populations migrate to wintering grounds in the open pampas and agricultural areas of South America (Argentina, Uruguay, southern Brazil). The species is included among the group of birds known as "neotropical migrants". Some individuals or small groups (20-30 birds) may winter in the U.S., including California (Delta Islands). This round trip journey may exceed 14,000 miles. The birds return to the nesting grounds and establish nesting territories in early March.

Swainson's hawks are monogamous and remain so until the loss of a mate (Palmer 1988). Nest construction and courtship continues through April. The clutch (commonly 3-4 eggs) is generally laid in early April to early May, but may occur later. Incubation lasts 34-35 days, with both parents participating in the brooding of eggs and young. The young fledge (leave the nest) approximately 42-44 days after hatching and remain with their parents until they depart in the fall. Large groups (up to 100+ birds) may congregate in holding areas in the fall and may exhibit a delayed migration depending upon forage availability. The specific purpose of these congregation areas is as yet unknown, but is likely related to: increasing energy reserves for migration; the timing of migration; aggregation into larger migratory groups (including assisting the young in learning migration routes); and providing a pairing and courtship opportunity for unattached adults.

Foraging Requirements

Swainson's hawk nests in the Central Valley of California are generally found in scattered trees or along riparian systems adjacent to agricultural fields or pastures. These open fields and pastures are the primary foraging areas. Major prey items for Central Valley birds include: California voles (*Microtus californicus*), valley pocket gophers (*Thomomys bottae*), deer mice (*Peromyscus maniculatus*), California ground squirrels (*Spermophilus beecheyi*), mourning doves (*Zenaida macroura*), ring-necked pheasants (*Phasianus colchicus*), meadowlarks (*Sturnella neglecta*), other passerines, grasshoppers (*Conocephalinae sp.*), crickets (*Gryllidae sp.*), and beetles (Estep 1989). Swainson's hawks generally search for prey by soaring in open country and agricultural fields similar to northern harriers (*Circus cyaneus*) and ferruginous hawks (*Buteo regalis*). Often several hawks may be seen foraging together following tractors or other farm equipment capturing prey escaping from farming operations. During the breeding season, Swainson's hawks eat mainly vertebrates (small rodents and reptiles), whereas during migration vast numbers of insects are consumed (Palmer 1988).

Department funded research has documented the importance of suitable foraging habitats (e.g., annual grasslands, pasture lands, alfalfa and other hay crops, and combinations of hay, grain and row crops) within an energetically efficient flight distance from active Swainson's hawk nests (Estep pers. comm.). Recent telemetry studies to determine foraging requirements have shown that birds may use in excess of 15,000 acres of habitat or range up to 18.0 miles from the nest in search of prey (Estep 1989, Babcock 1993). The prey base (availability and abundance) for the species is highly variable from year to year, with major prey population (small mammals and insects) fluctuations occurring based on rainfall patterns, natural cycles and agricultural cropping and harvesting patterns. Based on these variables, significant acreages of potential foraging habitat (primarily agricultural lands) should be preserved per nesting pair (or aggregation of

nesting pairs) to avoid jeopardizing existing populations. Preserved foraging areas should be adequate to allow additional Swainson's hawk nesting pairs to successfully breed and use the foraging habitat during good prey production years.

Suitable foraging habitat is necessary to provide an adequate energy source for breeding adults, including support of nestlings and fledglings. Adults must achieve an energy balance between the needs of themselves and the demands of nestlings and fledglings, or the health and survival of both may be jeopardized. If prey resources are not sufficient, or if adults must hunt long distances from the nest site, the energetics of the foraging effort may result in reduced nestling vigor with an increased likelihood of disease and/or starvation. In more extreme cases, the breeding pair, in an effort to assure their own existence, may even abandon the nest and young (Woodbridge 1985).

Prey abundance and availability is determined by land and farming patterns including crop types, agricultural practices and harvesting regimes. Estep (1989) found that 73.4% of observed prey captures were in fields being harvested, disced, mowed, or irrigated. Preferred foraging habitats for Swainson's hawks include:

- alfalfa;
- fallow fields;
- beet, tomato, and other low-growing row or field crops;
- dry-land and irrigated pasture;
- rice land (during the non-flooded period); and
- cereal grain crops (including corn after harvest).

Unsuitable foraging habitat types include crops where prey species (even if present) are not available due to vegetation characteristics (e.g. vineyards, mature orchards, and cotton fields, dense vegetation).

Nesting Requirements

Although the Swainson's hawk's current nesting habitat is fragmented and unevenly distributed, Swainson's hawks nest throughout most of the Central Valley floor. More than 85% of the known nests in the Central Valley are within riparian systems in Sacramento, Sutter, Yolo, and San Joaquin counties. Much of the potential nesting habitat remaining in this area is in riparian forests, although isolated and roadside trees are also used. Nest sites are generally adjacent to or within easy flying distance to alfalfa or hay fields or other habitats or agricultural crops which provide an abundant and available prey source. Department research has shown that valley oaks (*Quercus lobata*), Fremont's cottonwood (*Populus fremontii*), willows (*Salix* spp.), sycamores (*Platanus* spp.), and walnuts (*Juglans* spp.) are the preferred nest trees for Swainson's hawks (Bloom 1980, Schlorff and Bloom 1983, Estep 1989).

Fall and Winter Migration Habitats

During their annual fall and winter migration periods, Swainson's hawks may congregate in large groups (up to 100+ birds). Some of these sites may be used during delayed migration periods lasting up to three months. Such sites have been identified in Yolo, Tulare, Kern and San Joaquin counties and protection is needed for these critical foraging areas which support birds during their long migration.

Historical and Current Population Status

The Swainson's hawk was historically regarded as one of the most common and numerous raptor species in the state, so much so that they were often not given special mention in field notes. The breeding population has declined by an estimated 91% in California since the turn of the century (Bloom 1980). The historical Swainson's hawk population estimates are based on current densities and extrapolated based on the historical amount of available habitat. The historical population estimate is 4,284-17,136 pairs (Bloom 1980). In 1979, approximately 375 (± 50) breeding pairs of Swainson's hawks were estimated in California, and 280 (75%) of those pairs were estimated to be in the Central Valley (Bloom 1980). In 1988, 241 active breeding pairs were found in the Central Valley, with an additional 78 active pairs known in northeastern California. The 1989 population estimate was 430 pairs for the Central Valley and 550 pairs statewide (Estep, 1989). This difference in population estimates is probably a result of increased survey effort rather than an actual population increase.

Reasons for decline

The dramatic Swainson's hawk population decline has been attributed to loss of native nesting and foraging habitat, and more recently to the loss of suitable nesting trees and the conversion of agricultural lands. Agricultural lands have been converted to urban land uses and incompatible crops. In addition, pesticides, shooting, disturbance at the nest site, and impacts on wintering areas may have contributed to their decline. Although losses on the wintering areas in South America may occur, they are not considered significant since breeding populations outside of California are stable. The loss of nesting habitat within riparian areas has been accelerated by flood control practices and bank stabilization programs. Smith (1977) estimated that in 1850

over 770,000 acres of riparian habitat were present in the Sacramento Valley. By the mid-1980s, Warner and Hendrix (1984) estimated that there was only 120,000 acres of riparian habitat remaining in the Central Valley (Sacramento and San Joaquin Valleys combined). Based on Warner and Hendrix's estimates approximately 93% of the San Joaquin Valley and 73% of the Sacramento Valley riparian habitat has been eliminated since 1850.

MANAGEMENT STRATEGIES

Management and mitigation strategies for the Central Valley population of the Swainson's hawk should ensure that:

- suitable nesting habitat continues to be available (this can be accomplished by protecting existing nesting habitat from destruction or disturbance and by increasing the number of suitable nest trees); and
- foraging habitat is available during the period of the year when Swainson's hawks are present in the Central Valley (this should be accomplished by maintaining or creating adequate and suitable foraging habitat in areas of existing and potential nest sites and along migratory routes within the state).

A key to the ultimate success in meeting the Legislature's goal of maintaining habitat sufficient to preserve this species is the implementation of these management strategies in cooperation with project sponsors and local, state and federal agencies.

DEPARTMENT'S ROLES AND RESPONSIBILITIES IN PROJECT CONSULTATION AND ADMINISTRATION OF CEQA AND THE FISH AND GAME CODE

The Department, through its administration of the Fish and Game Code and its trust responsibilities, should continue its efforts to minimize further habitat destruction and should seek mitigation to offset unavoidable losses by (1) including the mitigation measures in this document in CEQA comment letters and/or as management conditions in Department issued Management Authorizations or (2) by developing project specific mitigation measures (consistent with the Commission's and the Legislature's mandates) and including them in CEQA comment letters and/or as management conditions in Fish and Game Code Section 2081 Management Authorizations issued by the Department and/or in Fish and Game Code Section 2090 Biological Opinions.

The Department should submit comments to CEQA Lead Agencies on all projects which adversely affect Swainson's hawks. CEQA requires a mandatory findings of significance if a project's impacts to threatened or endangered species are likely to occur (Sections 21001 fc), 21083. Guidelines 15380, 15064, 15065). Impacts must be: (1) avoided; or (2) appropriate mitigation must be provided to reduce impacts to less than significant levels; or (3) the lead agency must make and support findings of overriding consideration. If the CEQA Lead Agency makes a Finding of Overriding Consideration, it does not eliminate the project sponsor's obligation to comply with the take prohibitions of Fish and Game Code Section 2080. Activities

which result in (1) nest abandonment; (2) starvation of young; and/or (3) reduced health and vigor of eggs and nestlings may result in the take (killing) of Swainson's hawks incidental to otherwise lawful activities (urban development, recreational activities, agricultural practices, levee maintenance and similar activities). The taking of Swainson's hawk in this manner may be a violation of Section 2080 of the Fish and Game Code. To avoid potential violations of Fish and Game Code Section 2080, the Department should recommend and encourage project sponsors to obtain 2081 Management Authorizations.

In aggregate, the mitigation measures incorporated into CEQA comment letters and/or 2081 Management Authorizations for a project should be consistent with Section 2053 and 2054 of the Fish and Game Code. Section 2053 states, in part, "it is the policy of the state that state agencies should not approve projects as proposed which would jeopardize the continued existence of any endangered or threatened species or result in the destruction or adverse modification of habitat essential to the continued existence of those species, if there are reasonable and prudent alternatives available consistent with conserving the species and or its habitat which would prevent jeopardy" - Section 2054 states: "The Legislature further finds and declares that, in the event specific economic, social, and or other conditions make infeasible such alternatives, individual projects may be approved if appropriate mitigation and enhancement measures are provided."

State lead agencies are required to consult with the Department pursuant to Fish and Game Code Section 2090 to ensure that any action authorized, funded, or carried out by that state agency will not jeopardize the continued existence of any threatened or endangered species. Comment letters to State Lead Agencies should also include a reminder that the State Lead Agency has the responsibility to consult with the Department pursuant to Fish and Game Code Section 2090 and obtain a written findings (Biological Opinion). Mitigation measures included in Biological Opinions issued to State Lead Agencies must be consistent with Fish and Game Code Sections 2051-2054 and 2091-2092.

NEST SITE AND HABITAT LOCATION INFORMATION SOURCES

The Department's Natural Diversity Data Base (NDDB) is a continually updated, computerized inventory of location information on the State's rarest plants, animals, and natural communities. Department personnel should encourage project proponents and CEQA Lead Agencies, either directly or through CEQA comment letters, to purchase NDDB products for information on the locations of Swainson's hawk nesting areas as well as other sensitive species. The Department's Nongame Bird and Mammal Program also maintains information on Swainson's hawk nesting areas and may be contacted for additional information on the species.

Project applicants and CEQA Lead Agencies may also need to conduct site specific surveys (conducted by qualified biologists at the appropriate time of the year using approved protocols) to determine the status (location of nest sites, foraging areas, etc.) of listed species as part of the CEQA and 2081 Management Authorization process. Since these studies may require multiple years to complete, the Department shall identify any needed studies at the earliest possible time in the project review process. To facilitate project review and reduce the potential for costly

project delays, the Department should make it a standard practice to advise developers or others planning projects that may impact one or more Swainson's hawk nesting or foraging areas to initiate communication with the Department as early as possible .

MANAGEMENT CONDITIONS

Staff believes the following mitigation measures (nos. 1-4) are adequate to meet the Commission's and Legislature's policy regarding listed species and are considered as preapproved for incorporation into any Management Authorizations for the Swainson's hawk issued by the Department. The incorporation of measures 1-4 into a CEQA document should reduce a project's impact to a Swainson's hawk(s) to less than significant levels. Since these measures are Staff recommendations, a project sponsor or CEQA Lead agency may choose to negotiate project specific mitigation measures which differ. In such cases, the negotiated Management Conditions must be consistent with Commission and Legislative policy and be submitted to the ESD for review and approval prior to reaching agreement with the project sponsor or CEQA Lead Agency.

Staff recommended Management Conditions are:

1. No intensive new disturbances (e.g. heavy equipment operation associated with construction, use of cranes or draglines, new rock crushing activities) or other project related activities which may cause nest abandonment or forced fledging, should be initiated within 1/4 mile (buffer zone) of an active nest between March 1 - September 15 or until August 15 if a Management Authorization or Biological Opinion is obtained for the project. The buffer zone should be increased to 1/2 mile in nesting areas away from urban development (i.e. in areas where disturbance [e.g. heavy equipment operation associated with construction, use of cranes or draglines, new rock crushing activities] is not a normal occurrence during the nesting season). Nest trees should not be removed unless there is no feasible way of avoiding it. If a nest tree must be removed, a Management Authorization (including conditions to off-set the loss of the nest tree) must be obtained with the tree removal period specified in the Management Authorization, generally between October 1- February 1. If construction or other project related activities which may cause nest abandonment or forced fledging are necessary within the buffer zone, monitoring of the nest site (funded by the project sponsor) by a qualified biologist (to determine if the nest is abandoned) should be required . If it is abandoned and if the nestlings are still alive, the project sponsor shall fund the recovery and hacking (controlled release of captive reared young) of the nestling(s). Routine disturbances such as agricultural activities, commuter traffic, and routine facility maintenance activities within 1/4 mile of an active nest should not be prohibited.
2. Hacking as a substitute for avoidance of impacts during the nesting period may be used in unusual circumstances after review and approval of a hacking plan by ESD and WMD. Proponents who propose using hacking will be required to fund the full costs of the effort, including any telemetry work specified by the

Department.

3. To mitigate for the loss of foraging habitat (as specified in this document), the Management Authorization holder/project sponsor shall provide Habitat Management (HM) lands to the Department based on the following ratios:

(a) Projects within 1 mile of an active nest tree shall provide:

- one acre of HM land (at least 10% of the HM land requirements shall be met by fee title acquisition or a conservation easement allowing for the active management of the habitat, with the remaining 90% of the HM lands protected by a conservation easement [acceptable to the Department] on agricultural lands or other suitable habitats which provide foraging habitat for Swainson's hawk) for each acre of development authorized (1:1 ratio); or
- One-half acre of HM land (all of the HM land requirements shall be met by fee title acquisition or a conservation easement [acceptable to the Department] which allows for the active management of the habitat for prey production on-the HM lands) for each acre of development authorized (0.5:1 ratio).

(b) Projects within 5 miles of an active nest tree but greater than 1 mile from the nest tree shall provide 0.75 acres of HM land for each acre of urban development authorized (0.75:1 ratio). All HM lands protected under this requirement may be protected through fee title acquisition or conservation easement (acceptable to the Department) on agricultural lands or other suitable habitats which provide foraging habitat for Swainson's hawk.

(c) Projects within 10 miles of an active nest tree but greater than 5 miles from an active nest tree shall provide 0.5 acres of HM land for each acre of urban development authorized (0.5:1 ratio). All HM lands- protected under this requirement may be protected through fee title acquisition or a conservation easement (acceptable to the Department) on agricultural lands or other suitable habitats which provide foraging habitat for Swainson's hawk.

4. Management Authorization holders/project sponsors shall provide for the long-term management of the HM lands by funding a management endowment (the interest on which shall be used for managing the HM lands) at the rate of \$400 per HM land acre (adjusted annually for inflation and varying interest rates).

Some project sponsors may desire to provide funds to the Department for HM land protection. This option is acceptable to the extent the proposal is consistent with Department policy regarding acceptance of funds for land acquisition. All HM lands should be located in areas which are consistent with a multi-species habitat conservation focus. Management

Authorization holders/project sponsors who are willing to establish a significant mitigation bank (> 900 acres) should be given special consideration such as 1.1 acres of mitigation credit for each acre preserved.

PROJECT SPECIFIC MITIGATION MEASURES

Although this report includes recommended Management Measures, the Department should encourage project proponents to propose alternative mitigation strategies that provide equal or greater protection of the species and which also expedite project environmental review or issuance of a CESA Management Authorization. The Department and sponsor may choose to conduct cooperative, multi-year field studies to assess the site's habitat value and determine its use by nesting and foraging Swainson's hawk. Study plans should include clearly defined criteria for judging the project's impacts on Swainson's hawks and the methodologies (days of monitoring, foraging effort/efficiency, etc.) that will be used.

The study plans should be submitted to the Wildlife Management Division and ESD for review. Mitigation measures developed as a result of the study must be reviewed by ESD (for consistency with the policies of the Legislature and Fish and Game Commission) and approved by the Director.

EXCEPTIONS

Cities, counties and project sponsors should be encouraged to focus development on open lands within already urbanized areas. Since small disjunct parcels of habitat seldom provide foraging habitat needed to sustain the reproductive effort of a Swainson's hawk pair, Staff does not recommend requiring mitigation pursuant to CEQA nor a Management Authorization by the Department for infill (within an already urbanized area) projects in areas which have less than 5 acres of foraging habitat and are surrounded by existing urban development, unless the project area is within 1/4 mile of an active nest tree.

REVIEW

Staff should revise this report at least annually to determine if the proposed mitigation strategies should be retained, modified or if additional mitigation strategies should be included as a result of new scientific information.

LITERATURE CITED

- Babcock, K.W. 1993. Home range and habitat analysis of Swainson's hawks in West Sacramento. Michael Brandman Associates report prepared for the Southport Property Owner's Group, City of West Sacramento, CA. 21pp.
- Bechard, M.J. 1983. Food supply and the occurrence of brood reduction in Swainson's Hawk. *Wilson Bull.* 95(2):233-242.
- Bloom, P.H. 1980. The status of the Swainson's Hawk in California, 1979. Federal Aid in Wildlife Restoration, Project W-54-R-12, Nongame Wildl. Invest. job Final Report 11-8-0. 24p + appendix.
- Estep, J.A. 1989. Biology, movements, and habitat relationships of the Swainson's Hawk in the Central Valley of California, 1986-87. Calif. Dept. Fish and Game, Nongame Bird and Mammal Section Report, 53pp.
- Palmer, R.S. 1988a. Handbook of North American birds. Vol. 4: diurnal raptors (part 1). Yale Univ. Press, New Haven, CT.
- Palmer, R.S. 1988b. Handbook of North American birds. Vol. 5: diurnal raptors (part 2). Yale Univ. Press, New Haven, CT.
- Schlorff, R.W. and P.H. Bloom. 1983. Importance of riparian systems to nesting Swainson's Hawks in the Central Valley of California. pp 612-618. In: R.E Warner and K.M. Hendrix, (Eds.). 1984. California Riparian Systems. University of California Press, Berkeley.
- Smith, F. 1977. Short review of the status of riparian forests in California. In: Stet, A. (Ed.). Riparian forests in California: Their ecology and conservation. Inst. of Ecology Pubi. 15. Univ. of Calif., Davis.
- Warner, R.E. and K. M. Hendrix, Eds. 1984. California riparian systems; ecology, conservation, and productive management. University of California Press, Berkeley.
- Woodbridge, B. 1985. Biology and management of Swainson's Hawk in Butte Valley, California. U.S. Forest Service Report, 19pp.



To: Deepesh Tourani
Crawford & Bowen Planning, Inc.
113 N. Church Street, Suite 302
Visalia, CA 93291

Record Search 23-482

Date: December 4, 2023

Re: Dinuba Empire Estates Residential Project

County: Tulare

Map(s): Reedley 7.5'

CULTURAL RESOURCES RECORDS SEARCH

The California Office of Historic Preservation (OHP) contracts with the California Historical Resources Information System's (CHRIS) regional Information Centers (ICs) to maintain information in the CHRIS inventory and make it available to local, state, and federal agencies, cultural resource professionals, Native American tribes, researchers, and the public. Recommendations made by IC coordinators or their staff regarding the interpretation and application of this information are advisory only. Such recommendations do not necessarily represent the evaluation or opinion of the State Historic Preservation Officer in carrying out the OHP's regulatory authority under federal and state law.

The following are the results of a search of the cultural resource files at the Southern San Joaquin Valley Information Center. These files include known and recorded cultural resources sites, inventory and excavation reports filed with this office, and resources listed on the National Register of Historic Places, the OHP Built Environment Resources Directory, California State Historical Landmarks, California Register of Historical Resources, California Inventory of Historic Resources, and California Points of Historical Interest. Due to processing delays and other factors, not all of the historical resource reports and resource records that have been submitted to the OHP are available via this records search. Additional information may be available through the federal, state, and local agencies that produced or paid for historical resource management work in the search area.

PRIOR CULTURAL RESOURCE STUDIES CONDUCTED WITHIN THE PROJECT AREA AND THE ONE-HALF MILE RADIUS

According to the information in our files, there have been no previous cultural resource studies completed within the project area. There has been one cultural resource study completed within the half-mile radius: TU-00165.

KNOWN/RECORDED CULTURAL RESOURCES WITHIN THE PROJECT AREA AND THE ONE-HALF MILE RADIUS

According to the information in our files, there are no recorded resources within the project area. There are 11 recorded resources within the half-mile radius: P-54-004907, 004945, 005017, 005018, 005019, 005020, 005021, 005022, 005023, 005024, & 005025. These resources consist of historic era canals, single family properties, multi-family properties, & 1-3 story buildings.

There are no recorded cultural resources within the project area or radius that are listed in the National Register of Historic Places, the California Register of Historical Resources, the California Points of Historical Interest, California Inventory of Historic Resources, for the California State Historic Landmarks.

COMMENTS AND RECOMMENDATIONS

We understand this project proposes to construct 75 single-family residential units in the western portion of the City of Dinuba. We also understand that this project area is vacant agricultural land, with an existing dwelling that will be removed as a part of the project. As such, if this project will result in alteration or demolition of any existing structures more than 45 years old, then we recommend the structures first be recorded and evaluated for historical significance. If no structures more than 45 years old will be impacted, then no further cultural resource investigation is recommended in this regard. Please note that agriculture does not constitute previous development, as it does not destroy cultural resources, but merely moves them around within the plow zone. Because this project area has not been previously studied for cultural resources, it is unknown if any are present. As such, prior to ground disturbance activities, we recommend a qualified, professional consultant conduct a field survey to determine if cultural resources are present. A list of qualified consultants can be found at www.chrisinfo.org.

We also recommend that you contact the Native American Heritage Commission in Sacramento. They will provide you with a current list of Native American individuals/organizations that can assist you with information regarding cultural resources that may not be included in the CHRIS Inventory and that may be of concern to the Native groups in the area. The Commission can consult their "Sacred Lands Inventory" file to determine what sacred resources, if any, exist within this project area and the way in which these resources might be managed. Finally, please consult with the lead agency on this project to determine if any other cultural resource investigation is required. If you need any additional information or have any questions or concerns, please contact our office at (661) 654-2289.

By:



Jeremy E David, Assistant Coordinator

Date: December 4, 2023

Please note that invoices for Information Center services will be sent under separate cover from the California State University, Bakersfield Accounting Office.

Draft Traffic Impact Analysis Report

Empire Estates

Located on the Northwest Corner of Avenue 412
and Road 72

In the City of Dinuba, California

Prepared for:

Land Design
6702 North Cedar Avenue, Suite #201
Fresno, CA 93710

March 5, 2024

Project No. 029-005



Traffic Engineering, Transportation Planning, & Parking Solutions

516 W. Shaw Ave., Ste. 103

Fresno, CA 93704

Phone: (559) 570-8991

www.JLBtraffic.com



Traffic Engineering, Transportation Planning, & Parking Solutions

Traffic Impact Analysis Report

For the Empire Estates located on the Northwest Corner of Avenue 412 and Road 72

In the City of Dinuba, California

March 5, 2024

This Draft Traffic Impact Analysis Report has been prepared under the direction of a licensed Traffic Engineer. The licensed Traffic Engineer attests to the technical information contained therein and has judged the qualifications of any technical specialists providing engineering data from which recommendations, conclusions and decisions are based.

Prepared by:

Jose Luis Benavides, PE, TE

President



Traffic Engineering, Transportation Planning, & Parking Solutions

516 W. Shaw Ave., Ste. 103

Fresno, CA 93704

Phone: (559) 570-8991

www.JLBtraffic.com

Table of Contents

Introduction and Summary	1
Introduction	1
Summary	1
Existing Traffic Conditions.....	1
Existing plus Project Traffic Conditions.....	1
Near Term plus Project Traffic Conditions.....	2
Cumulative Year 2046 plus Project Traffic Conditions.....	2
Queuing Analysis.....	2
Project’s Equitable Fair Share	2
Scope of Work	3
Study Facilities	3
Study Intersections	3
Study Segments.....	3
Study Scenarios.....	4
Existing Traffic Conditions.....	4
Existing plus Project Traffic Conditions.....	4
Near Term plus Project Traffic Conditions.....	4
Cumulative Year 2046 plus Project Traffic Conditions.....	4
LOS Methodology	5
LOS Thresholds	5
Operational Analysis Assumptions and Defaults	6
Existing Traffic Conditions.....	7
Roadway Network.....	7
Traffic Signal Warrants.....	8
Results of Existing Level of Service Analysis	8
Existing plus Project Traffic Conditions.....	12
Project Description.....	12
Project Access	12
Project Trip Generation	12
Trip Distribution	12

Bikeways 12

Transit 13

Roadway Network..... 13

Traffic Signal Warrants..... 13

Results of Existing plus Project Level of Service Analysis 13

Near Term plus Project Traffic Conditions 18

 Description of Near Term Projects..... 18

 Roadway Network..... 18

 Traffic Signal Warrants..... 18

 Results of Near Term plus Project Level of Service Analysis..... 18

Cumulative Year 2046 plus Project Traffic Conditions..... 22

 Roadway Network..... 22

 Traffic Signal Warrants..... 22

 Results of Cumulative Year 2046 plus Project Level of Service Analysis 22

Queuing Analysis 25

Project’s Pro-Rata Fair Share of Future Transportation Improvements 28

Conclusions and Recommendations 29

 Existing Traffic Conditions..... 29

 Existing plus Project Traffic Conditions..... 29

 Near Term plus Project Traffic Conditions..... 30

 Cumulative Year 2046 plus Project Traffic Conditions..... 30

 Queuing Analysis..... 31

 Project’s Equitable Fair Share 31

Study Participants..... 32

References..... 33



List of Figures

Figure 1: Vicinity Map	10
Figure 2: Existing - Traffic Volumes, Geometrics and Controls	11
Figure 3: Project Site Plan.....	15
Figure 4: Project Only Trips	16
Figure 5: Existing plus Project - Traffic Volumes, Geometrics and Controls	17
Figure 6: Near Term Projects' Trip Assignment.....	20
Figure 7: Near Term plus Project - Traffic Volumes, Geometrics and Controls.....	21
Figure 8: Cumulative Year 2046 plus Project - Traffic Volumes, Geometrics and Controls	24

List of Tables

Table I: Existing Intersection LOS Results	9
Table II: Existing Segment LOS Results	9
Table III: Project Trip Generation.....	12
Table IV: Existing plus Project Intersection LOS Results.....	14
Table V: Existing plus Project Segment LOS Results.....	14
Table VI: Near Term Projects' Trip Generation	18
Table VII: Near Term plus Project Intersection LOS Results	19
Table VIII: Near Term plus Project Segment LOS Results	19
Table IX: Cumulative Year 2046 plus Project Intersection LOS Results	23
Table X: Cumulative Year 2046 plus Project Segment LOS Results	23
Table XI: Queuing Analysis	26
Table XII: Project's Fair Share of Future Roadway Improvements.....	28

List of Appendices

- Appendix A: Scope of Work
- Appendix B: Traffic Counts
- Appendix C: Traffic Modeling
- Appendix D: Methodology
- Appendix E: Existing Traffic Conditions
- Appendix F: Existing plus Project Traffic Conditions
- Appendix G: Near Term plus Project Traffic Conditions
- Appendix H: Cumulative Year 2046 plus Project Traffic Conditions
- Appendix I: Traffic Signal Warrants

Introduction and Summary

Introduction

This Report describes a **Traffic Impact Analysis (TIA)** prepared by **JLB Traffic Engineering, Inc. (JLB)** for **Empire Estates (Project)** to be located on the northwest corner of Avenue 412 and Road 72. The Project proposes to develop 75 dwelling units of single family detached housing. Based on information provided by JLB, the Project is consistent with the City of Dinuba *General Plan Policies Statement*. Figure 1 shows the location of the proposed Project site relative to the surrounding roadway network.

The purpose of the TIA is to evaluate the potential on-site and off-site traffic impacts, identify short-term and long-term roadway needs, determine potential roadway improvement measures and identify any critical traffic issues that should be addressed in the ongoing planning process. The TIA primarily focused on evaluating traffic conditions at study intersections that may potentially be impacted by the proposed Project. The Scope of Work was prepared via consultation with City of Dinuba, County of Tulare and Caltrans staff.

Summary

The potential traffic impacts of the proposed Project were evaluated in accordance with the standards set forth by the Level of Service (LOS) policies of the City of Dinuba, County of Tulare and Caltrans.

Existing Traffic Conditions

- At present, the study intersection of Road 70 at Avenue 416 exceeds its LOS threshold during the PM peak period. Additional details as to the recommended improvements for this intersection are presented later in this Report.
- At present, all study segments operate at an acceptable LOS during both peaks.

Existing plus Project Traffic Conditions

- Access to and from the Project site will primarily be from two (2) proposed access points. The first access point will be located along the east side of Road 70 approximately 500 feet north of Avenue 412 and is proposed to be full access. The second access point will be located along the west side of Road 72 approximately 300 feet north of Avenue 412 and is also proposed to be full access.
- At buildout, the proposed Project is estimated to generate approximately 774 daily trips, 57 AM peak hour trips and 76 PM peak hour trips.
- It is recommended that the Project construct Class II Bikeways its frontage to Road 72 and ADA compliant walkways along its frontages to Road 70, Road 72 and Avenue 412.
- Under this scenario, the study intersection of Road 70 at Avenue 416 is projected to exceed its LOS threshold during the PM peak period. Additional details as to the recommended improvements for these intersections are presented later in this report.
- Under this scenario, all study segments are projected to operate at an acceptable LOS during both peak periods.

Near Term plus Project Traffic Conditions

- The total trip generation for the Near Term Projects is 12,598 weekday daily trips, 1,849 weekday AM peak hour trips and 1,550 weekday PM peak hour trips.
- Under this scenario, the study intersection of Road 70 at Avenue 416 is projected to exceed its LOS threshold during both peak periods. Additional details as to the recommended improvements for these intersections are presented later in this report.
- Under this scenario, all study segments are projected to operate at an acceptable LOS during both peak periods.

Cumulative Year 2046 plus Project Traffic Conditions

- Under this scenario, the study intersections of Road 70 at Avenue 416 and Road 72 at Avenue 416 are projected to exceed their LOS threshold during one or both peak periods. Additional details as to the recommended improvements for these intersections are presented later in this Report.
- Under this scenario, all study segments are projected to operate at an acceptable LOS during both peak periods.

Queuing Analysis

- It is recommended that the City consider left-turn and right-turn lane storage lengths as indicated in the Queuing Analysis.

Project's Equitable Fair Share

- It is recommended that the Project contribute its equitable Fair Share as presented in Table XII for those future improvements which are not covered by an existing impact fee program or grant funds.

Scope of Work

The TIA focused on evaluating traffic conditions at study intersections that may potentially be impacted by the proposed Project. On November 22, 2023, a Draft Scope of Work for the preparation of a Traffic Impact Analysis for this Project was provided to the City of Dinuba, County of Tulare and Caltrans for their review and comment. On December 1, 2023, the City of Dinuba requested that the year of the counts be used for the base year model, the fitted equation get used for Project trip generation, the intersection of Road 72 at Avenue 416 be included, and the segments of Avenue 412 between Alta Avenue and Road 72 be included. On December 1, 2023, Caltrans responded to the Draft Scope of Work with no comments. On December 4, 2023, the County of Tulare requested that it be verified that the Project is being annexed to the City of Dinuba, whether the land use is consistent with the City of Dinuba *Focused General Plan Amendment* and that the County of Tulare VMT Guidelines be used.

As a result of the comments listed above, the TIA utilizes the base year 2023 model. The TIA analyses the Project trip generation based on the fitted equation. The TIA also includes the intersection of Road 72 at Avenue 416 as well as the segments of Avenue 412 between Road 72 and Alta Avenue and will utilize the County of Tulare VMT Guidelines. It was determined that the Project will be annexed into the City of Dinuba and that the Project has submitted the application for Rezone and Annexation to the City of Dinuba per the City of Dinuba *Focused General Plan Amendment*. The Draft Scope of Work and all relevant comments are included in Appendix A.

Study Facilities

The existing intersection peak hour turning movement and segment volume counts were conducted at the study intersections in November and December 2023 while schools in the vicinity of the Project site were in session. The intersection turning movement counts include pedestrian and bicycle volumes. The traffic counts for the existing study intersections and segments are contained in Appendix B. The existing intersection turning movement volumes, intersection geometrics and traffic controls are illustrated in Figure 2.

Study Intersections

1. Avenue 416 / Road 70
2. Avenue 416 / Road 72
3. Avenue 412 / Road 70
4. Avenue 412 / Road 72
5. Avenue 412 / Monte Vista Drive

Study Segments

1. Avenue 412 between Road 72 and Road 74
2. Avenue 412 between Road 74 and Monte Vista Drive
3. Avenue 412 between Monte Vista Drive and Samantha Way
4. Avenue 412 between Samantha Way and Alta Avenue

Study Scenarios

Existing Traffic Conditions

This scenario evaluates the Existing Traffic Conditions based on existing traffic volumes and roadway conditions from traffic counts and field surveys conducted in November and December 2023.

Existing plus Project Traffic Conditions

This scenario evaluates total traffic volumes and roadway conditions based on the Existing plus Project Traffic Conditions. The Existing plus Project traffic volumes were obtained by adding the Project Only Trips to the Existing Traffic Conditions scenario. The Project Only Trips to the study facilities were developed based on existing travel patterns, the TCAG Project Select Zone, the surrounding roadway network, engineering judgment, knowledge of the study area, existing residential and commercial densities, and the City of Dinuba's *General Plan Policies Statement* Circulation Element in the vicinity of the Project site. The TCAG Project Select Zone is contained in Appendix C.

Near Term plus Project Traffic Conditions

This scenario evaluates total traffic volumes and roadway conditions based on the Near Term plus Project Traffic Conditions. The Near Term plus Project traffic volumes were obtained by adding the near term related trips to the Existing plus Project Traffic Conditions scenario.

Cumulative Year 2046 plus Project Traffic Conditions

This scenario evaluates total traffic volumes and roadways conditions based on the Cumulative Year 2046 plus Project Traffic Conditions. The Cumulative Year 2046 plus Project traffic volumes were obtained by using the TCAG model (Base Year 2023 and Cumulative Year 2046) and existing traffic counts. Under this scenario, the increment method, was utilized to determine the Cumulative Year 2046 traffic volumes. The TCAG model results provided are contained in Appendix C.

LOS Methodology

LOS is a qualitative index of the performance of an element of the transportation system. LOS is a rating scale running from “A” to “F”, with “A” indicating no congestion of any kind and “F” indicating unacceptable congestion and delays. LOS in this study describes the operating conditions for signalized and unsignalized intersections.

The *Highway Capacity Manual* (HCM) 7th Edition is the standard reference published by the Transportation Research Board and contains the specific criteria and methods to be used in assessing LOS. U-turn movements were analyzed using HCM 2000 methodologies and would yield more accurate results for the reason that HCM 6 Edition methodologies do not allow the analysis of U-turns. Lane configurations not reflective of existing conditions are a result of software limitations and thus represent a worst-case scenario. Synchro software was used to define LOS in this study. Details regarding these calculations are included in Appendix D.

While LOS is no longer the criteria of significance for traffic impacts in the state of California, the City of Dinuba continues to apply congestion-related conditions or requirements for land development projects through planning approval processes outside of CEQA Guidelines in order to continue the implementation of the City of Dinuba’s *General Plan Policies Statement*.

LOS Thresholds

Caltrans no longer considers delay as a significant impact to the environment, for land use projects and plans. According to the Caltrans document VMT Focused Transportation Impact Study Guidelines dated May 2020, Caltrans review of land use projects and plans is focused on a VMT metric consistent with CEQA. In this TIA, however, all study intersections fall within the City of Dinuba SOI. Therefore, the City of Dinuba LOS thresholds are utilized.

The Tulare County General Plan has established LOS D as the acceptable level of traffic congestion on county roads and streets that fall entirely outside the Sphere of Influence (SOI) of a city. As all study facilities fall within the SOI of the City of Dinuba, the LOS threshold of the City of Dinuba is used in this Report.

The City of Dinuba *General Plan Policies Statement* has established LOS C as the acceptable level of traffic congestion on local, minor collector, collector and arterial streets in the City of Dinuba. Additionally, LOS D is deemed acceptable for road segments and intersections which have been identified as already operating at that level. The *Dinuba General Plan Update Background Report* has not identified any of the study intersections or segments as already operating at LOS D. As all the study facilities fall within the City of Dinuba and are not identified to operate at LOS D already, LOS C is used to evaluate the potential LOS impacts at all study facilities.

Operational Analysis Assumptions and Defaults

The following operational analysis values, assumptions and defaults were used in this study to ensure a consistent analysis of LOS among the various scenarios.

- The following assumptions are utilized for the timing of intersections.
 - Yellow time consistent with the *California Manual on Uniform Traffic Control Devices* (CA MUTCD) based on approach speeds (Caltrans, 2024).
 - Yellow time of 3.2 seconds for left-turn phases.
 - All-red clearance intervals of 1.0 second for all phases.
 - Walk intervals of 7.0 seconds.
 - Flashing Don't Walk based on 3.5 feet/second walking speed with yellow plus all-red clearance subtracted and 2.0 seconds added.
- At existing intersections, the heavy vehicle factor observed for each intersection, or a minimum of 3 percent, were utilized under all scenarios.
- At future intersections, a heavy vehicle factor of 3 percent was utilized under all scenarios.
- The number of observed pedestrians at existing intersections was utilized under all study scenarios.
- An average of 10 pedestrian calls per hour at signalized intersections.
- At existing intersections, the observed approach Peak Hour Factor (PHF) is utilized in the Existing, Existing plus Project and Near Term plus Project scenarios.
- For the Cumulative Year 2046 scenario, a PHF of 0.88 is utilized in the Cumulative Year 2046 plus Project scenario.

Existing Traffic Conditions

Roadway Network

The Project site and surrounding study area are illustrated in Figure 1. Important roadways serving the Project are discussed below.

Avenue 416 (El Monte Way) is an existing east-west divided arterial in the vicinity of the proposed Project site. In this area, Avenue 416 extends throughout the City of Dinuba SOI. The City of Dinuba *General Plan Policies Statement* designates Avenue 416 as a four-lane arterial through the City of Dinuba SOI.

Avenue 412 (Sierra Way) is an existing east-west two-lane undivided collector adjacent to the proposed Project site. In this area, Avenue 412 extends between Road 64 and Alta Avenue. The City of Dinuba *General Plan Policies Statement* designates Avenue 412 as a two-lane collector throughout the City of Dinuba.

Road 70 is an existing north-south undivided local roadway adjacent to the proposed Project site. In this area, Road 70 extends between Avenue 416 and Kamm Avenue. The City of Dinuba *General Plan Policies Statement* does not have any specific designations for Road 70. Therefore Road 70 would be considered a local street.

Road 72 (Englehart Avenue) is an existing north-south undivided arterial adjacent to the proposed Project site. In this area, Road 72 extends between the City of Dinuba northern limit and Avenue 412. The City of Dinuba *General Plan Policies Statement* designates Road 72 as a four-lane arterial from the City of Dinuba northern limit and Kamm Avenue.

Monte Vista Drive is an existing north-south divided collector in the vicinity of the proposed Project site. In this area, Monte Vista Drive extends between Avenue 416 and Avenue 412. The City of Dinuba *General Plan Policies Statement* designates Monte Vista Drive as a two-lane collector between Avenue 416 and Avenue 412.

Traffic Signal Warrants

The CA MUTCD indicates that an engineering study of traffic conditions, pedestrian characteristics and physical features of an intersection shall be conducted to determine whether the installation of traffic signal controls are justified. The CA MUTCD provides a total of nine (9) warrants to evaluate the need for traffic signal controls. These warrants include 1) Eight-Hour Vehicular Volume, 2) Four-Hour Vehicular Volume, 3) Peak Hour, 4) Pedestrian Volume, 5) School Crossing, 6) Coordinated Signal System, 7) Crash Experience, 8) Roadway Network and 9) Intersection Near a Grade Crossing. Signalization of an intersection may be appropriate if one or more of the signal warrants is satisfied. However, the CA MUTCD also states that “[t]he satisfaction of a signal warrant or warrants shall not in itself require the installation of a traffic control signal” (Caltrans, 2024).

If traffic signal warrants are satisfied when a LOS threshold impact is identified at an unsignalized intersection, then installation of a traffic signal control may serve as an improvement measure. For instances where traffic signal warrants are satisfied, a traffic signal control is not considered to be the default improvement measure. Since the installation of a traffic signal control typically requires the construction of additional lanes, an attempt is made to improve the intersection approach lane geometrics in order to improve its LOS while maintaining the existing intersection controls. If the additional lanes did not result in acceptable LOS at the intersection, then in those cases implementation of a traffic signal control would be considered.

Warrant 3 was prepared for the unsignalized intersections under the Existing Traffic Conditions scenario. These warrants are contained in Appendix I. Warrant 3 is met for the intersection of Road 70 at Avenue 416 during the AM peak period. Based on the traffic signal warrants, operational analysis and engineering judgment, signalization of the intersection of Road 70 at Avenue 416 is not recommended. The CA MUTCD states “satisfaction of a signal warrant or warrants shall not in itself require the installation of a traffic signal.”

Results of Existing Level of Service Analysis

Figure 2 illustrates the Existing Traffic Conditions turning movement volumes, intersection geometrics and traffic controls. LOS worksheets for the Existing Traffic Conditions scenario are provided in Appendix E. Table I presents a summary of the Existing peak hour LOS at the study intersections. Table II presents a summary of the Existing peak hour LOS at the study segments.

At present, the intersection of Road 70 at Avenue 416 exceeds its LOS threshold during the PM peak period. It is recommended that the following improvements be considered for implementation to improve the LOS at this intersection.

- Road 70 / Avenue 416
 - Implement a raised median island along Avenue 416 to prevent left-turn and through movements from Road 70;
 - Modify the northbound left-through-right to a right-turn lane;
 - Modify the southbound left-through-right to a right turn lane; and

- o Furthermore, traffic will need to be rerouted due to the proposed limited access at the intersection of Road 70 at Avenue 416. Traffic volumes at the intersections of Road 72 at Avenue 416, Road 70 at Avenue 412 and Road 72 at Avenue 412 will be altered. As a result, those intersections will appear in the improved Synchro reports. No additional modifications as a result of this shift in traffic patterns were necessary.

Table I: Existing Intersection LOS Results

ID	Intersection	Intersection Control	AM (7 - 9) Peak Hour		PM (4 - 6) Peak Hour	
			Average Delay (sec/veh)	LOS	Average Delay (sec/veh)	LOS
1	Road 70 / Avenue 416	Two-Way Stop	24.5	C	33.6	D
		Two-Way Stop (Improved)	10.6	B	12.2	B
2	Road 72 / Avenue 416	Traffic Signal	19.8	B	23.0	C
		Traffic Signal	20.1	C	23.3	C
3	Road 70 / Avenue 412	Two-Way Stop	10.2	B	9.7	A
		Two-Way Stop	10.2	B	10.2	B
4	Road 72 / Avenue 412	All-Way Stop	8.3	A	8.6	A
		All-Way Stop	8.5	A	8.7	A
5	Monte Vista Drive / Avenue 412	One-Way Stop	12.7	B	13.0	B

Note: LOS = Level of Service based on average delay on signalized intersections and All-Way STOP Controls
 LOS for two-way and one-way STOP controlled intersections are based on the worst approach/movement of the minor street.

At present, all study segments operate at an acceptable LOS.

Table II: Existing Segment LOS Results

ID	Segment	Limits	Lanes	24-hour Volume	AM Peak Volume	AM LOS	PM Peak Volume	PM LOS
1	Avenue 412	Road 72 and Road 74	2	4,293	330	A	410	A
2	Avenue 412	Road 74 and Monte Vista Drive	2	7,275	555	B	706	C
3	Avenue 412	Monte Vista Drive and Samantha Way	2	6,062	464	B	612	B
4	Avenue 412	Samantha Way and Alta Avenue	2	5,902	443	B	549	B

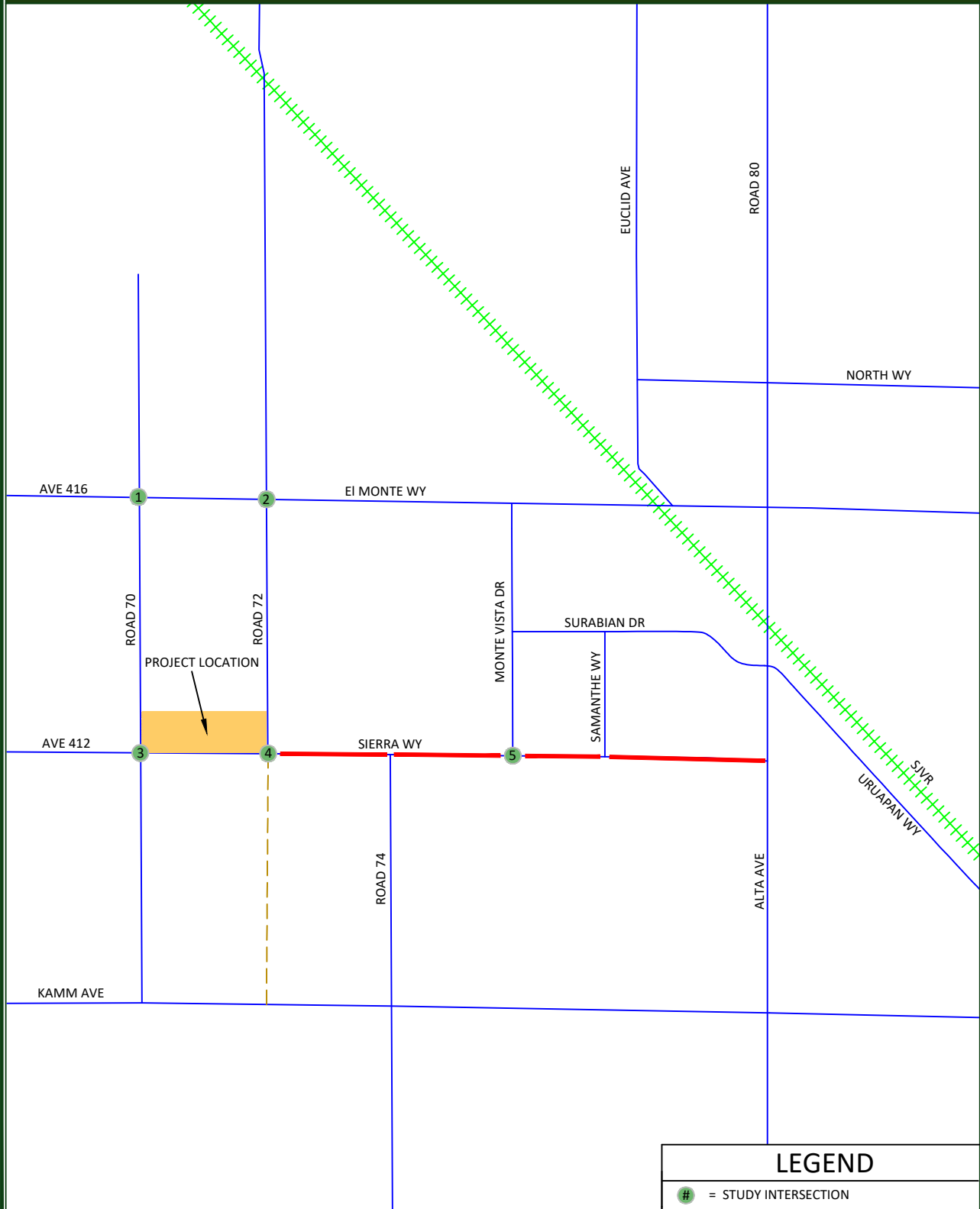

LEGEND

- # = STUDY INTERSECTION
- = FUTURE ROADWAY
- = STUDY SEGMENT



Not To Scale



516 W. Shaw Ave., Ste. 103, Fresno, CA 93704
PHONE: (559) 570-8991, EMAIL: info@JLBtraffic.com, www.JLBtraffic.com

Empire Estates - City of Dinuba Existing - Traffic Volumes, Geometrics and Controls

Figure 2

1.	Rd 70 & Ave 416	2.	Rd 72 & Ave 416	3.	Rd 70 & Ave 412	4.	Rd 72 & Ave 412

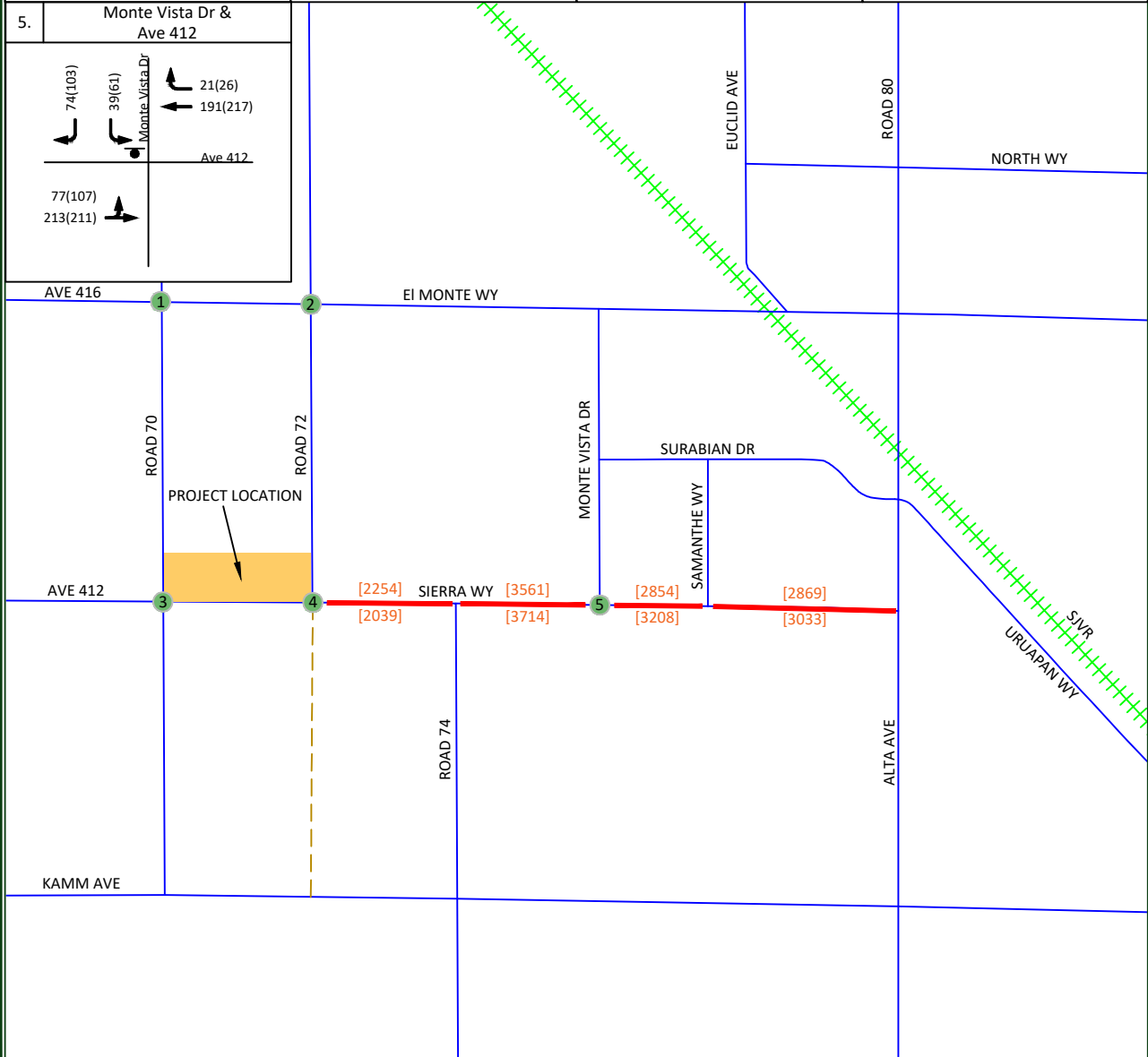

JLB TRAFFIC
ENGINEERING, INC.

516 W. Shaw Ave., Ste. 103, Fresno, CA 93704
PHONE: (559) 570-8991, EMAIL: info@JLBtraffic.com, www.JLBtraffic.com

LEGEND

- # = STUDY INTERSECTION
- - - = FUTURE ROADWAY
- = STUDY SEGMENT
- ⬮ = STOP SIGN
- 🚦 = TRAFFIC SIGNAL
- XX = AM PEAK HOUR TRIPS
- (XX) = PM PEAK HOUR TRIPS
- [XX] = DAILY TRIPS

Not To Scale

Existing plus Project Traffic Conditions

Project Description

The Project proposes to develop 75 dwelling units of single family detached housing on the northwest corner of Avenue 412 and Road 72. Based on information provided to JLB, the Project is consistent with the City of Dinuba *General Plan Policies Statement*. Figure 3 illustrates the latest Project Site Plan.

Project Access

Based on the Project Site Plan, access to and from the Project site will be from two (2) access points at buildout. The first access point will be located along the east side of Road 70 approximately 500 feet north of Avenue 412 and is proposed to be full access. The second access point will be located along the west side of Road 72 approximately 300 feet north of Avenue 412 and is also proposed to be full access.

Project Trip Generation

The trip generation rates for the proposed Project were obtained from the 11th Edition of the Trip Generation Manual published by the Institute of Transportation Engineers (ITE). Table III presents the trip generation for the proposed Project with trip generation rates for 75 dwelling units of Single-Family Detached Housing (210). As requested by the City of Dinuba Consultant Engineer, the fitted curve was used to determine the project's trip generation. As such, the rates contained in Table III are the equivalent rate when one uses the fitted curve and 75 single family dwelling units. At buildout, the proposed Project is estimated to generate approximately 774 daily trips, 57 AM peak hour trips and 76 PM peak hour trips.

Table III: Project Trip Generation

Land Use (ITE Code)	Size	Unit	Daily		AM (7-9) Peak Hour					PM (4-6) Peak Hour						
			Rate	Total	Trip Rate	In	Out	In	Out	Total	Trip Rate	In	Out	In	Out	Total
						%	%									
Single-Family Detached Housing (210)	75	d.u.	10.32	774	0.76	26	74	15	42	57	1.01	63	37	48	28	76
Total Driveway Trips				774				15	42	57				48	28	76

Note: d.u. = Dwelling Units

Trip Distribution

The trip distribution assumptions were developed based on existing travel patterns, the TCAG model Project Select Zone, the existing roadway network, engineering judgment, knowledge of the study area, existing residential and commercial densities and the City of Dinuba Circulation Element in the vicinity of the Project site. The Project's trip generation data was provided to TCAG to conduct a Project-specific Traffic Analysis Zone (TAZ) analysis. The TCAG Project Select Zone results are contained in Appendix C. Figure 4 illustrates the Project Only Trips at the study intersections.

Bikeways

The City of Dinuba *General Plan Policies Statement* does not have a dedicated bicycle plan. In the vicinity of the Project site, a Class II Bikeway exists along Monte Vista Way. Street standards for arterials within the City of Dinuba *General Plan Policies Statement* include parking and/or a bike lane in addition to other features. Therefore, it is recommended that the Project construct a Class II Bikeway along its frontage to Road 72.

Transit

Tulare County Regional Transportation Agency (TCRTA) is the transit operator in the City of Dinuba. At present there are four (4) TCRTA transit routes that operates in the direct vicinity of the proposed Project site. D1 runs throughout the City of Dinuba and operates on approximately hour-long intervals weekdays and weekends. The nearest stop to the Project is located on the east side of Road 72 approximately 300 feet north of Avenue 416. D4 runs throughout the City of Dinuba and operates on approximately hour-long intervals weekdays and weekends. The nearest stop to the Project is located on the east side of Monte vista Drive approximately 400 feet north of Surabian Drive. C50 runs between Dinuba, Delft Colony, London and Traver. This route operates on inconsistent intervals on weekdays and weekends. The nearest stop to the Project is located on the east side of Monte vista Drive approximately 400 feet north of Surabian Drive. DC runs between Reedley and Dinuba and operates on approximately hour-long intervals weekdays and weekends. The nearest stop to the Project is located on the east side of Monte vista Drive approximately 400 feet north of Surabian Drive. Retention of the existing and expansion of future transit routes is dependent on transit ridership demand and available funding. TCRTA is considering expansion to its on-demand micro transit service in the areas of Dinuba and Woodlake at the time that this Report is written.

Roadway Network

The Existing plus Project Traffic Conditions scenario assumes that the existing roadway geometrics and traffic controls will remain in place with the exception of the Project with its access points. Figure 5 illustrates the assumed intersection geometrics and traffic controls for these intersections under this scenario.

Traffic Signal Warrants

Warrant 3 was prepared for the unsignalized study intersections under the Existing plus Project Traffic Conditions scenario. These warrants are contained in Appendix I. Under this scenario, the intersection of Road 70 at Avenue 416 is projected to satisfy the peak hour signal warrant during the AM peak period. Based on the traffic signal warrants, operational analysis and engineering judgment, signalization of the intersection of Road 70 at Avenue 416 is not recommended. The CA MUTCD states "satisfaction of a signal warrant or warrants shall not in itself require the installation of a traffic signal."

Results of Existing plus Project Level of Service Analysis

Figure 5 illustrates the Existing plus Project turning movement volumes, intersection geometrics and traffic controls. LOS worksheets for the Existing plus Project Traffic Conditions scenario are provided in Appendix F. Table IV presents a summary of the Existing plus Project peak hour LOS at the study intersections. Table V presents a summary of the Existing plus Project peak hour LOS at the study segments.

Under this scenario, the intersection of Road 70 at Avenue 416 is projected to exceed its LOS threshold during the PM peak period. It is recommended that the following improvements be considered for implementation to improve the LOS at this intersection.

- Road 70 / Avenue 416
 - Implement a raised median island along Avenue 416 to prevent left-turn and through movements from Road 70;
 - Modify the northbound left-through-right to a right-turn lane;
 - Modify the southbound left-through-right to a right turn lane; and
 - Furthermore, traffic will need to be rerouted due to the proposed limited access at in the intersection of Road 70 at Avenue 416. Traffic volumes at the intersections of Road 72 at Avenue 416, Road 70 at Avenue 412 and Road 72 at Avenue 412 will be altered. As a result, those intersections will appear in the improved Synchro reports. No additional modifications as a result of this shift in traffic patterns were necessary.

Table IV: Existing plus Project Intersection LOS Results

ID	Intersection	Intersection Control	AM (7 - 9) Peak Hour		PM (4 - 6) Peak Hour	
			Average Delay (sec/veh)	LOS	Average Delay (sec/veh)	LOS
1	Road 70 / Avenue 416	Two-Way Stop	24.8	C	35.5	E
		Two-Way Stop (Improved)	10.6	B	12.2	B
2	Road 72 / Avenue 416	Traffic Signal	19.9	B	23.8	C
		Traffic Signal	20.2	C	24.2	C
3	Road 70 / Avenue 412	Two-Way Stop	10.2	B	9.9	A
		Two-Way Stop	10.4	B	10.3	B
4	Road 72 / Avenue 412	All-Way Stop	8.5	A	8.7	A
		All-Way Stop	8.6	A	8.7	A
5	Monte Vista Drive / Avenue 412	One-Way Stop	12.8	B	13.1	B

Note: LOS = Level of Service based on average delay on signalized intersections and All-Way STOP Controls
LOS for two-way and one-way STOP controlled intersections are based on the worst approach/movement of the minor street.

Under this scenario, all study segments are projected to operate at an acceptable LOS.

Table V: Existing plus Project Segment LOS Results

ID	Segment	Limits	Lanes	24-hour Volume	AM Peak Volume	AM LOS	PM Peak Volume	PM LOS
1	Avenue 412	Road 72 and Road 74	2	4,521	347	A	432	A
2	Avenue 412	Road 74 and Monte Vista Drive	2	7,439	568	B	721	C
3	Avenue 412	Monte Vista Drive and Samantha Way	2	6,172	473	B	616	B
4	Avenue 412	Samantha Way and Alta Avenue	2	6,006	452	B	553	B

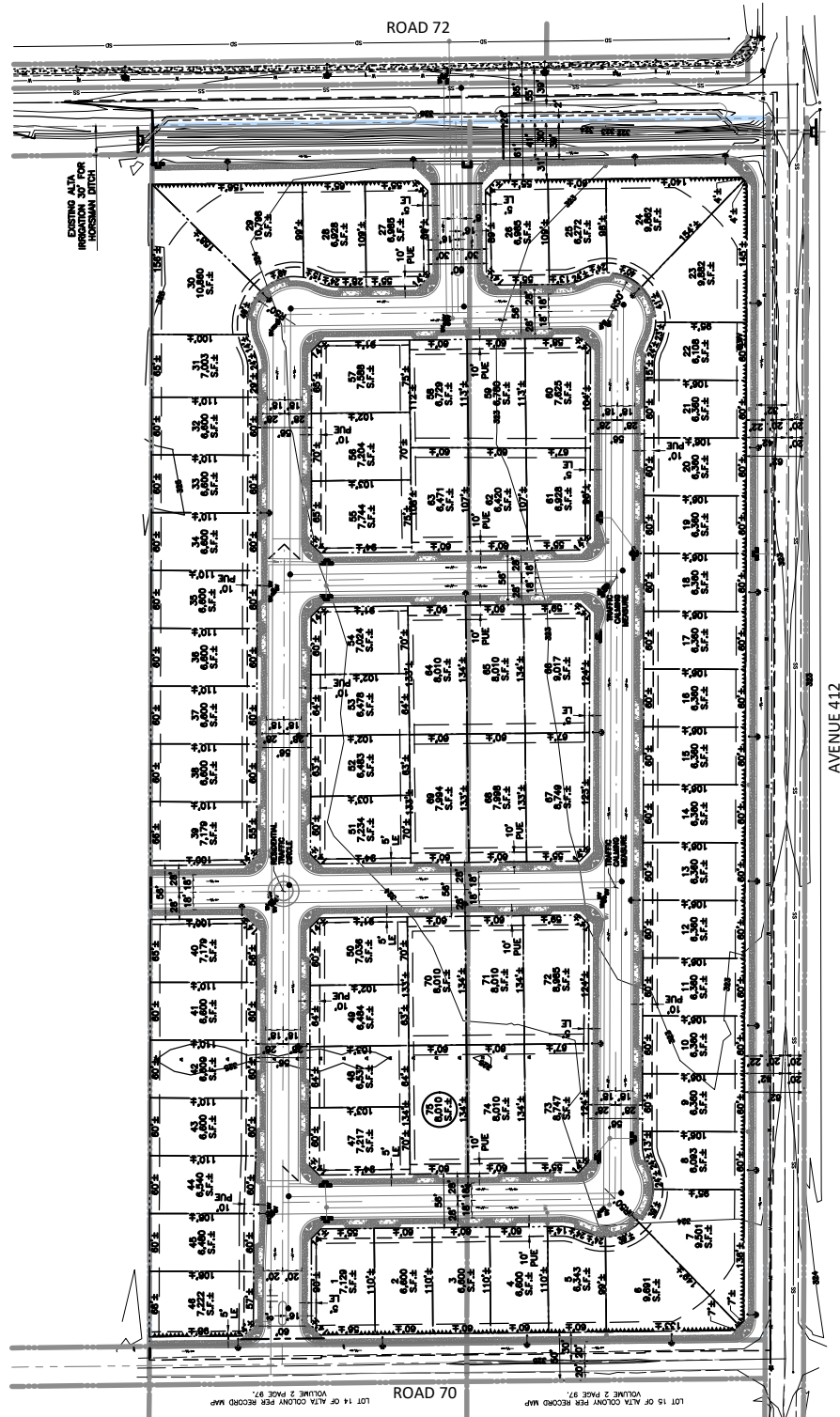

516 W. Shaw Ave., Ste. 103, Fresno, CA 93704
PHONE: (559) 570-8991, EMAIL: info@JLBtraffic.com, www.JLBtraffic.com



Not To Scale

Empire Estates - City of Dinuba Project Only Trips

Figure 4

1.	Rd 70 & Ave 416	2.	Rd 72 & Ave 416	3.	Rd 70 & Ave 412	4.	Rd 72 & Ave 412

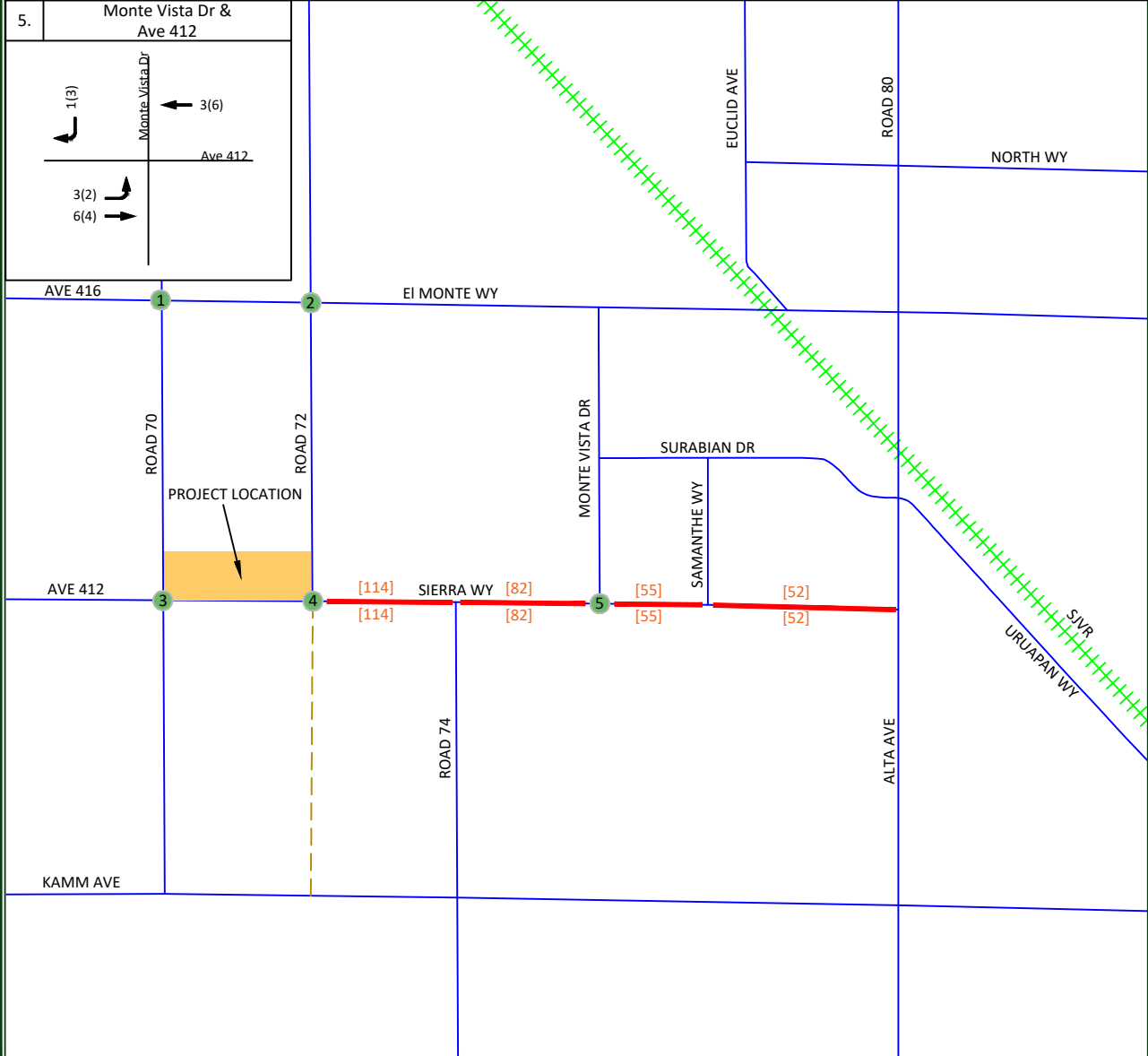

LEGEND

- # = STUDY INTERSECTION
- - - = FUTURE ROADWAY
- = STUDY SEGMENT
- XX = AM PROJECT ONLY TRIPS
- (XX) = PM PROJECT ONLY TRIPS
- [XX] = DAILY PROJECT TRIPS

Not To Scale

516 W. Shaw Ave., Ste. 103, Fresno, CA 93704
 PHONE: (559) 570-8991, EMAIL: info@JLBtraffic.com, www.JLBtraffic.com

Empire Estates - City of Dinuba Existing plus Project - Traffic Volumes, Geometrics and Controls

Figure 5

<p>1. Rd 70 & Ave 416</p> <p>Wilsonia Ave Ave 416 Rd 70</p> <p>0(1) 0(0) 2(1) 1(2) 616(648) 38(27) 0(0) 530(909) 59(40) 52(29) 0(0) 33(27)</p>	<p>2. Rd 72 & Ave 416</p> <p>Rd 72 Ave 416 Rd 70</p> <p>109(66) 94(72) 74(106) 32(104) 406(505) 28(31) 59(127) 418(667) 79(82) 45(76) 60(97) 28(41)</p>	<p>3. Rd 70 & Ave 412</p> <p>Rd 70 Ave 412 Rd 70</p> <p>2(0) 78(38) 18(23) 17(16) 1(1) 39(37) 1(1) 3(0) 1(0) 2(1) 59(53) 28(28)</p>	<p>4. Rd 72 & Ave 412</p> <p>Rd 72 Ave 412 Rd 70</p> <p>12(15) 149(158) 121(168) 42(43) 15(11) 35(32)</p>
--	---	---	---

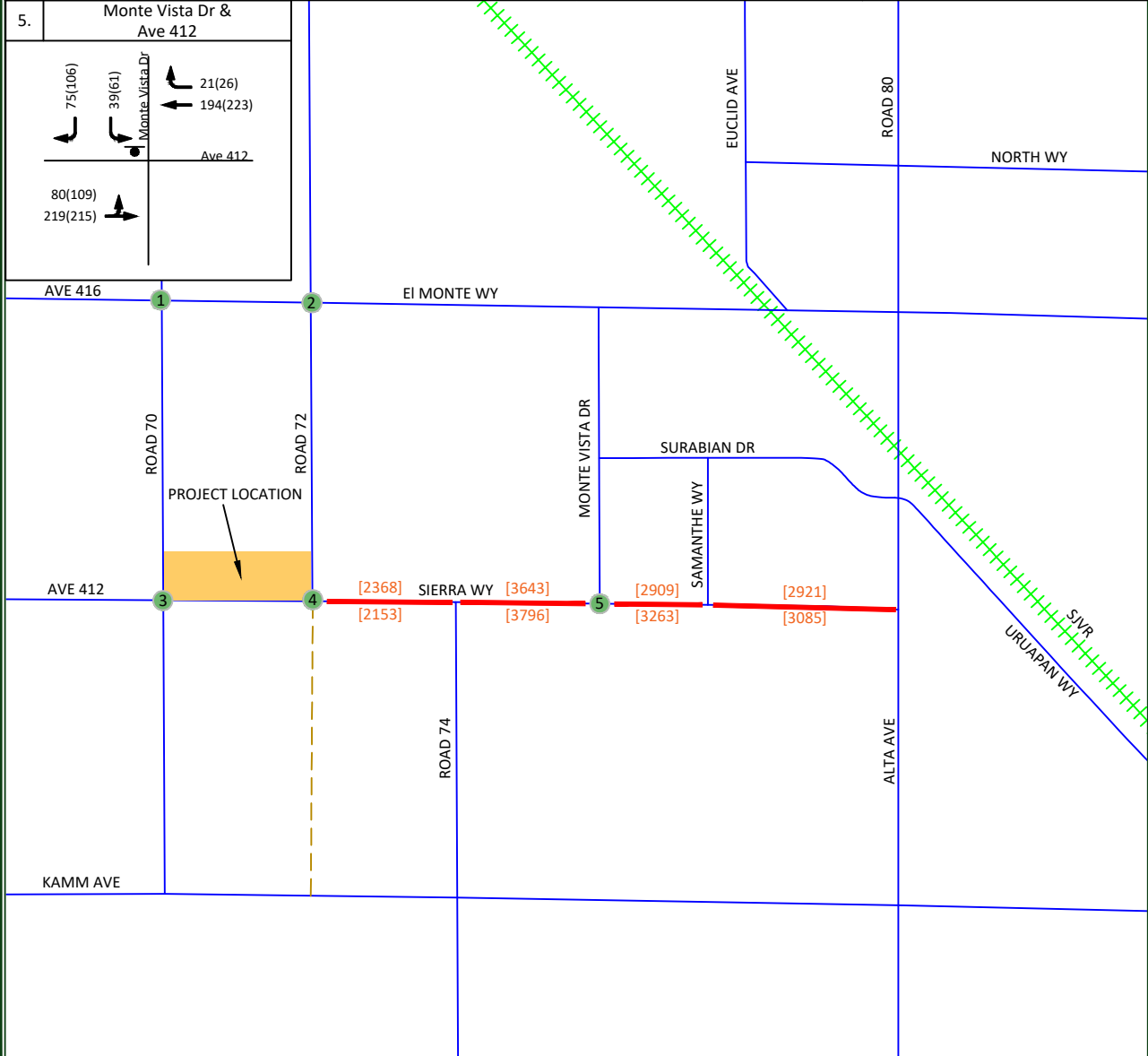

LEGEND

- # = STUDY INTERSECTION
- - - = FUTURE ROADWAY
- = STUDY SEGMENT
- ⬮ = STOP SIGN
- 🚦 = TRAFFIC SIGNAL
- XX = AM PEAK HOUR TRIPS
- (XX) = PM PEAK HOUR TRIPS
- [XX] = DAILY TRIPS

Not To Scale

516 W. Shaw Ave., Ste. 103, Fresno, CA 93704
PHONE: (559) 570-8991, EMAIL: info@JLBtraffic.com, www.JLBtraffic.com

Near Term plus Project Traffic Conditions

Description of Near Term Projects

Near Term Projects consist of developments that are either under construction, built but not fully occupied, are not built but have final site development review (SDR) approval, or for which the lead agency or responsible agencies have knowledge of. The City of Dinuba, County of Tulare and Caltrans staff were consulted throughout the preparation of this TIA regarding Near Term Projects that could potentially impact the study intersections. JLB conducted a reconnaissance of the surrounding area to confirm the Near Term Projects. Therefore, the Near Term Projects listed in Table VI were within proximity of the Project site.

Table VI: Near Term Projects' Trip Generation

<i>Near Term Project ID</i>	<i>Near Term Project Name</i>	<i>Daily Trips</i>	<i>AM Peak Hour</i>	<i>PM Peak Hour</i>
A	DUSD High School ¹	5,130	1,290	870
B	Hanjrah Petroleum Gas Station ¹	4,827	364	420
C	Montebella Subdivision ¹	1,537	113	153
D	Trevino Subdivision ¹	444	33	43
E	Vineyard Estates ¹	660	49	64
Total Near Term Project Trips		12,598	1,849	1,550

Note: 1 = Trip Generation prepared by JLB Traffic Engineering, Inc. based on readily available information

The trip generation listed in Table VI is that which is anticipated to be added to the streets and highways by Near Term Projects. As shown in Table VI, the total trip generation for the Near Term Projects is 12,598 weekday daily trips, 1,849 weekday AM peak hour trips and 1,550 weekday PM peak hour trips. Figure 6 illustrates the location of the Near Term Projects and their combined trip assignment to the study intersections under the Near Term plus Project Traffic Conditions scenario.

Roadway Network

The Near Term plus Project Traffic Conditions scenario assumes that the Existing plus Project Traffic Conditions roadway geometrics and traffic controls will remain in place. Figure 7 illustrates the assumed intersection geometrics and traffic controls for these intersections under this scenario.

Traffic Signal Warrants

Warrant 3 was prepared for the unsignalized intersections under the Near Term plus Project Traffic Conditions scenario. These warrants are contained in Appendix I. Under this scenario, the intersection of Road 70 at Avenue 416 is projected to satisfy the peak hour signal warrant during the AM peak period. Based on the traffic signal warrants, operational analysis and engineering judgment, signalization of the intersection of Road 70 at Avenue 416 is not recommended. The CA MUTCD states "satisfaction of a signal warrant or warrants shall not in itself require the installation of a traffic signal."

Results of Near Term plus Project Level of Service Analysis

Figure 7 illustrates the Near Term plus Project turning movement volumes, intersection geometrics and traffic controls. LOS worksheets for the Near Term plus Project Traffic Conditions scenario are provided in Appendix G. Table VII presents a summary of the Near Term plus Project peak hour LOS at the study

intersections. Table VIII presents a summary of the Near Term plus Project peak hour LOS at the study segments.

Under this scenario, the intersection of Road 70 at Avenue 416 is projected to exceed its LOS threshold during the PM peak period. It is recommended that the following improvements be considered for implementation to improve the LOS at this intersection.

- Road 70 / Avenue 416
 - Implement a raised median island along Avenue 416 to prevent left-turn and through movements from Road 70;
 - Modify the northbound left-through-right to a right-turn lane;
 - Modify the southbound left-through-right to a right turn lane; and
 - Furthermore, traffic will need to be rerouted due to the proposed limited access at in the intersection of Road 70 at Avenue 416. Traffic volumes at the intersections of Road 72 at Avenue 416, Road 70 at Avenue 412 and Road 72 at Avenue 412 will be altered. As a result, those intersections will appear in the improved Synchro reports. No additional modifications as a result of this shift in traffic patterns were necessary.

Table VII: Near Term plus Project Intersection LOS Results

ID	Intersection	Intersection Control	AM (7 - 9) Peak Hour		PM (4 - 6) Peak Hour	
			Average Delay (sec/veh)	LOS	Average Delay (sec/veh)	LOS
1	Road 70 / Avenue 416	Two-Way Stop	30.9	D	47.4	E
		Two-Way Stop (Improved)	10.9	B	12.9	B
2	Road 72 / Avenue 416	Traffic Signal	25.9	C	32.0	C
		Traffic Signal	26.2	C	32.4	C
3	Road 70 / Avenue 412	Two-Way Stop	10.2	B	9.9	A
		Two-Way Stop	10.4	B	10.3	B
4	Road 72 / Avenue 412	All-Way Stop	8.9	A	9.1	A
		All-Way Stop	9.1	A	9.3	A
5	Monte Vista Drive / Avenue 412	One-Way Stop	13.2	B	13.5	B

Note: LOS = Level of Service based on average delay on signalized intersections and All-Way STOP Controls
 LOS for two-way and one-way STOP controlled intersections are based on the worst approach/movement of the minor street.

Under this scenario, all study segments are projected to operate at an acceptable LOS.

Table VIII: Near Term plus Project Segment LOS Results

ID	Segment	Limits	Lanes	24-hour Volume	AM Peak Volume	AM LOS	PM Peak Volume	PM LOS
1	Avenue 412	Road 72 and Road 74	2	5,315	405	A	496	A
2	Avenue 412	Road 74 and Monte Vista Drive	2	7,783	592	B	748	C
3	Avenue 412	Monte Vista Drive and Samantha Way	2	6,516	497	B	630	B
4	Avenue 412	Samantha Way and Alta Avenue	2	6,350	476	B	567	B

Empire Estates - City of Dinuba Near Term plus Project - Traffic Volumes, Geometrics and Controls

Figure 7

1.	Rd 70 & Ave 416	2.	Rd 72 & Ave 416	3.	Rd 70 & Ave 412	4.	Rd 72 & Ave 412

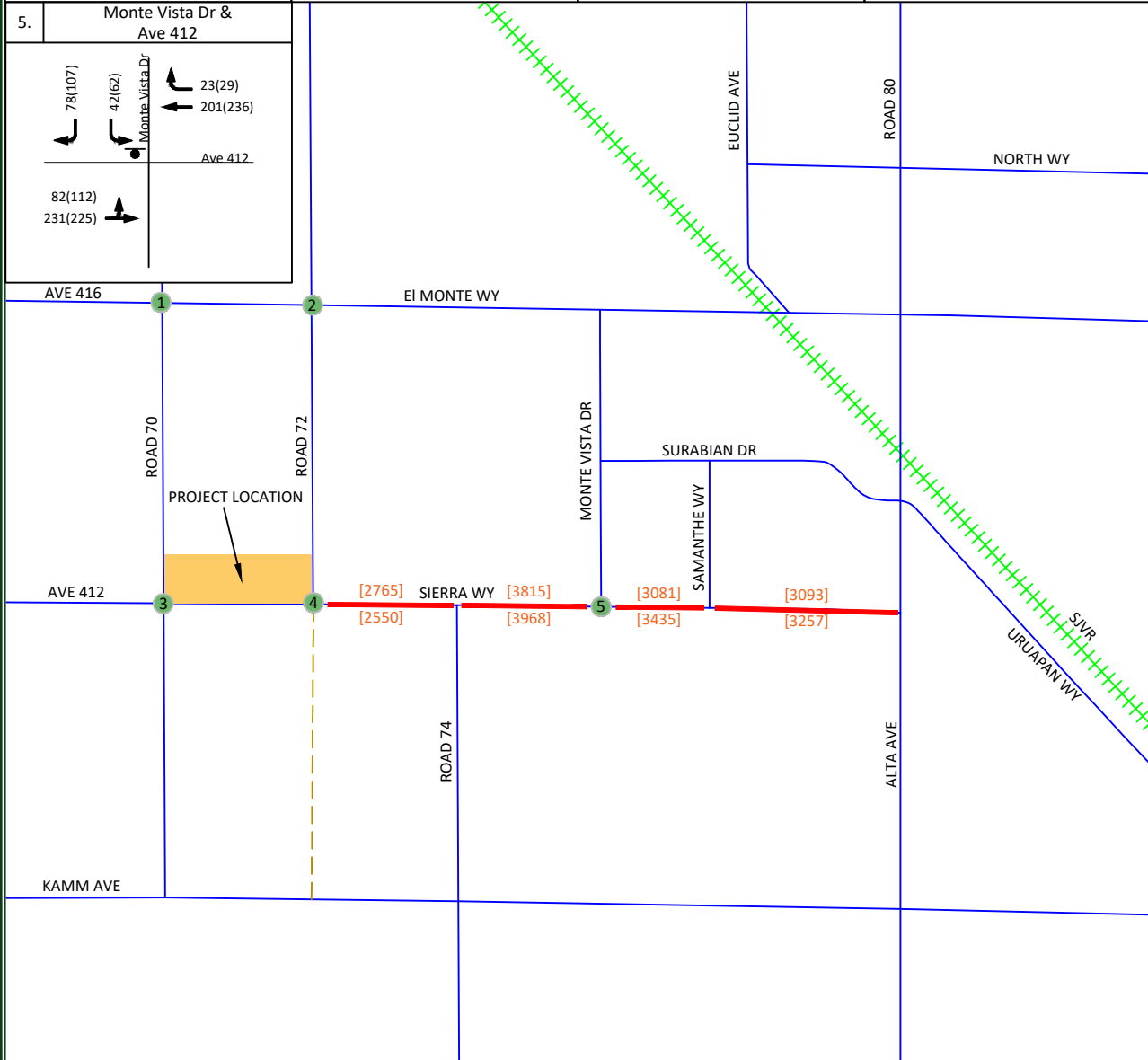

JLB TRAFFIC
ENGINEERING, INC.

516 W. Shaw Ave., Ste. 103, Fresno, CA 93704
PHONE: (559) 570-8991, EMAIL: info@JLBtraffic.com, www.JLBtraffic.com

LEGEND

- # = STUDY INTERSECTION
- - - = FUTURE ROADWAY
- = STUDY SEGMENT
- ⬮ = STOP SIGN
- 🚦 = TRAFFIC SIGNAL
- XX = AM PEAK HOUR TRIPS
- (XX) = PM PEAK HOUR TRIPS
- [XX] = DAILY TRIPS

Not To Scale

Cumulative Year 2046 plus Project Traffic Conditions

Roadway Network

The Cumulative Year 2046 plus Project Traffic Conditions scenario assumes that the Near Term plus Project roadway geometrics and traffic controls will remain in place with one exception. Avenue 72 is projected to be constructed between Avenue 412 and Kamm Avenue by the Cumulative Year 2046 plus Project scenario. Figure 8 illustrates the assumed intersection geometrics and traffic controls for the study intersections under this scenario.

Traffic Signal Warrants

Warrant 3 was prepared for the unsignalized intersections under the Cumulative Year 2046 plus Project Traffic Conditions scenario. These warrants are contained in Appendix I. Under this scenario, the intersections of Road 70 at Avenue 416, Road 72 at Avenue 412 and Monte Vista Drive at Avenue 412 are projected to satisfy the peak hour signal warrant during one of the peak periods. Based on the traffic signal warrants, operational analysis and engineering judgment, signalization of these unsignalized intersections is not recommended. The CA MUTCD states “satisfaction of a signal warrant or warrants shall not in itself require the installation of a traffic signal.”

Results of Cumulative Year 2046 plus Project Level of Service Analysis

Figure 8 illustrates the Cumulative Year 2046 plus Project turning movement volumes, intersection geometrics and traffic controls. LOS worksheets for the Cumulative Year 2046 plus Project Traffic Conditions scenario are provided in Appendix H. Table IX presents a summary of the Cumulative Year 2046 plus Project peak hour LOS at the study intersections. Table X presents a summary of the Cumulative Year 2046 plus Project peak hour LOS at the study segments.

Under this scenario, the intersections of Road 70 at Avenue 416 and Road 72 at Avenue 416 are projected to exceed their LOS threshold during one or both peak periods. It is recommended that the following improvements be considered for implementation to improve the LOS at these intersections.

- Road 70 / Avenue 416
 - Implement a raised median island along Avenue 416 to prevent left-turn and through movements from Road 70;
 - Modify the northbound left-through-right to a right-turn lane;
 - Modify the southbound left-through-right to a right turn lane; and
 - Furthermore, traffic will need to be rerouted due to the proposed limited access at in the intersection of Road 70 at Avenue 416. Traffic volumes at the intersections of Road 72 at Avenue 416, Road 70 at Avenue 412 and Road 72 at Avenue 412 will be altered. As a result, those intersections will appear in the improved Synchro reports. No additional modifications as a result of this shift in traffic patterns were necessary.
- Road 72 / Avenue 416
 - Add a northbound right-turn lane;
 - Modify the northbound through-right lane to a through lane; and
 - Modify the traffic signal to accommodate the added lanes.

Table IX: Cumulative Year 2046 plus Project Intersection LOS Results

ID	Intersection	Intersection Control	AM (7 - 9) Peak Hour		PM (4 - 6) Peak Hour	
			Average Delay (sec/veh)	LOS	Average Delay (sec/veh)	LOS
1	Road 70 / Avenue 416	Two-Way Stop	48.8	E	102.3	F
		Two-Way Stop (Improved)	11.4	B	14.0	B
2	Road 72 / Avenue 416	Traffic Signal	28.7	C	39.0	D
		Traffic Signal (Improved)	27.4	C	34.8	C
3	Road 70 / Avenue 412	Two-Way Stop	10.6	B	10.2	B
		Two-Way Stop	10.8	B	10.6	B
4	Road 72 / Avenue 412	All-Way Stop	10.0	A	11.7	B
		All-Way Stop	10.3	B	12.0	B
5	Monte Vista Drive / Avenue 412	One-Way Stop	13.5	C	16.7	C

Note: LOS = Level of Service based on average delay on signalized intersections and All-Way STOP Controls
 LOS for two-way and one-way STOP controlled intersections are based on the worst approach/movement of the minor street.

Under this scenario, all study segments are projected to operate at an acceptable LOS.

Table X: Cumulative Year 2046 plus Project Segment LOS Results

ID	Segment	Limits	Lanes	24-hour Volume	AM Peak Volume	AM LOS	PM Peak Volume	PM LOS
1	Avenue 412	Road 72 and Road 74	2	5,521	432	A	532	B
2	Avenue 412	Road 74 and Monte Vista Drive	2	9,079	711	B	885	C
3	Avenue 412	Monte Vista Drive and Samantha Way	2	7,362	592	B	696	C
4	Avenue 412	Samantha Way and Alta Avenue	2	7,196	571	B	633	C

<p>1. Rd 70 & Ave 416</p>	<p>2. Rd 72 & Ave 416</p>	<p>3. Rd 70 & Ave 412</p>	<p>4. Rd 72 & Ave 412</p>
-------------------------------	-------------------------------	-------------------------------	-------------------------------

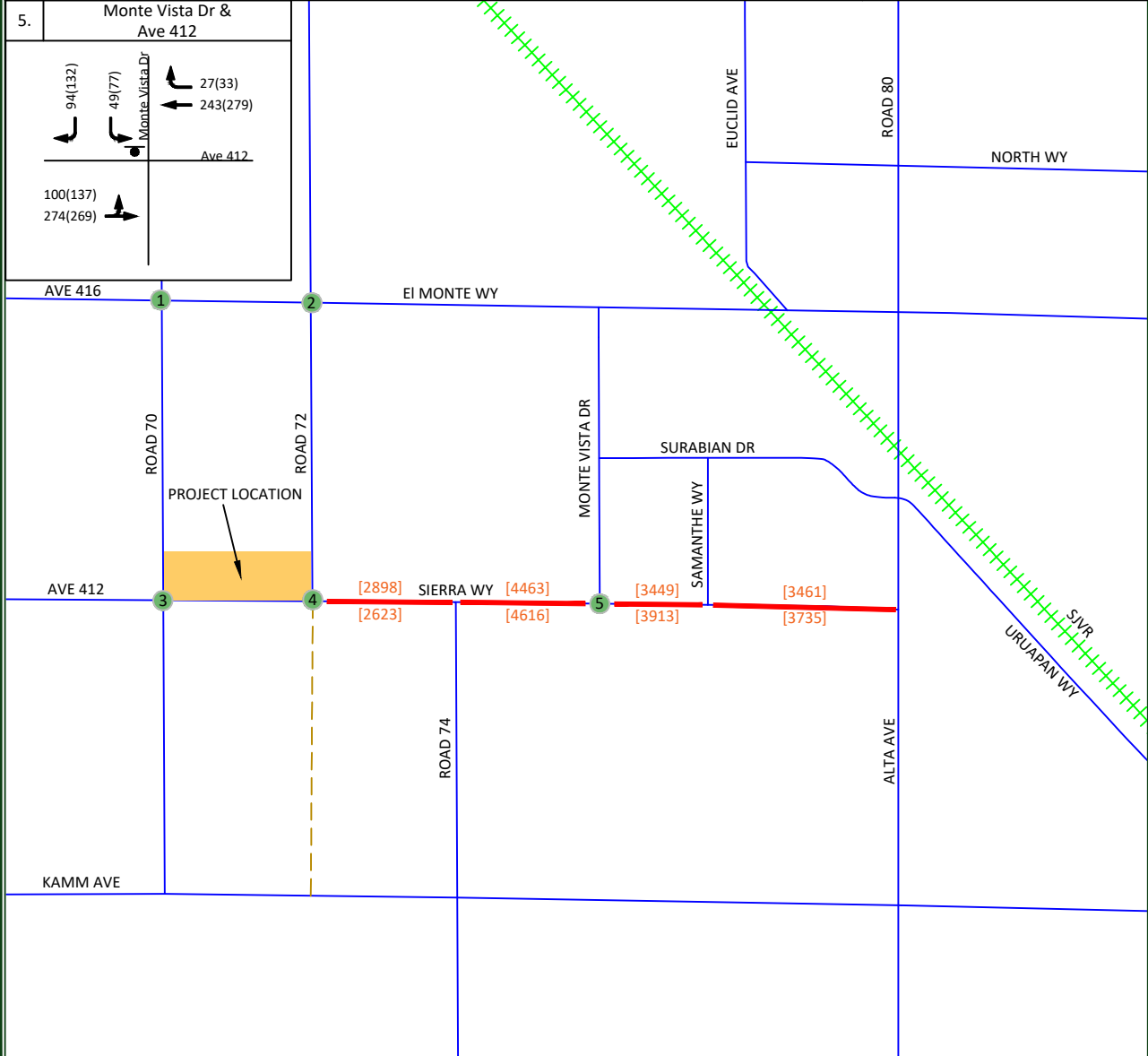

516 W. Shaw Ave., Ste. 103, Fresno, CA 93704
 PHONE: (559) 570-8991, EMAIL: info@JLBtraffic.com, www.JLBtraffic.com

LEGEND

- = STUDY INTERSECTION
- = FUTURE ROADWAY
- = STUDY SEGMENT
- = STOP SIGN
- = TRAFFIC SIGNAL
- XX = AM PEAK HOUR TRIPS
- (XX) = PM PEAK HOUR TRIPS
- [XX] = DAILY TRIPS

Not To Scale

Queuing Analysis

Table XI provides a queue length summary for left-turn and right-turn lanes at the study intersections under all study scenarios. The queuing analyses for the study intersections are contained in the LOS worksheets for the respective scenarios. Appendix D contains the methodologies used to evaluate these intersections. Queuing analyses were completed using SimTraffic output information. Synchro provides both 50th and 95th percentile maximum queue lengths (in feet). According to the *Synchro Studio 11 User Guide*, “the 50th percentile maximum queue is the maximum back of queue on a typical cycle and the 95th percentile queue is the maximum back of queue with 95th percentile volumes” (Cubic ITS, Inc., 2019). The queues shown in Table XI are the 95th percentile queue lengths for the respective lane movements.

The *California Highway Design Manual* (CA HDM) provides guidance for determining deceleration lengths for the left-turn and right-turn lanes based on design speeds. According to the CA HDM, tapers for right-turn lanes are “usually unnecessary since main line traffic need not be shifted laterally to provide space for the right-turn lane. If, in some rare instances, a lateral shift were needed, the approach taper would use the same formula as for a left-turn lane” (Caltrans, 2019). Therefore, a bay taper length pursuant to the CA HDM would need to be added, as necessary, to the recommended storage lengths presented in Table XI.

The storage capacity for the Cumulative Year 2046 plus Project Traffic Conditions shall be based on the SimTraffic output files and engineering judgment. The values in bold presented in Table XI are the projected queue lengths that will likely need to be accommodated by the Cumulative Year 2046 plus Project Traffic Conditions scenario. At the remaining approaches of the study intersections, the existing storage capacity will be sufficient to accommodate the maximum queue.

Table XI: Queuing Analysis

ID	Intersection	Existing Queue Storage Length (ft.)		Existing		Existing plus Project		Near Term plus Project		Cumulative Year 2046 plus Project	
				AM	PM	AM	PM	AM	PM	AM	PM
1	Road 70 / Avenue 416	Eastbound Left	150	0	0	0	0	0	0	0	9
		Eastbound Through	>500	0	0	0	0	0	0	0	0
		Eastbound Through-Right	>500	0	0	0	0	0	0	15	0
		Westbound Left	150	40	36	31	43	34	32	40	40
		Westbound Through	>500	0	0	0	0	0	0	0	0
		Westbound Through-Right	>500	0	0	0	0	0	0	0	0
		Northbound Left-Through-Right	>500	*	*	*	*	*	*	*	*
		Northbound Right	*	38	36	38	34	37	35	43	41
		Southbound Left-Through-Right	>500	*	*	*	*	*	*	*	*
		Southbound Right	*	11	11	11	8	11	14	23	25
2	Road 72 / Avenue 416	Eastbound Left	250	88	130	59	124	103	254	125	299
		Eastbound Through	>500	126	204	142	169	110	222	174	345
		Eastbound Through-Right	>500	147	215	160	180	124	212	202	336
		Westbound Left	190	41	52	44	59	66	87	100	196
		Westbound Through	>500	134	160	137	176	160	237	166	327
		Westbound Through-Right	>500	111	167	123	183	173	245	188	303
		Northbound Left	95	118	102	114	117	101	139	125	155
		Northbound Through-Right	>500	101	103	97	123	93	174	*	*
		Northbound Through	*	*	*	*	*	*	*	94	205
		Northbound Right	*	*	*	*	*	*	*	60	75
		Southbound Left	80	85	112	99	126	151	164	167	168
		Southbound Through	>500	97	95	102	100	201	393	231	357
		Southbound Right	200	55	53	66	53	130	231	81	185
3	Road 70 / Avenue 412	Eastbound Left-Through-Right	>500	15	9	21	14	20	9	12	0
		Westbound Left-Through-Right	>500	47	44	43	45	41	45	43	44
		Northbound Left-Through-Right	>500	0	0	8	0	0	0	0	0
		Southbound Left-Through-Right	>500	0	7	0	0	8	11	8	21

Note: * = Does not exist or is not projected to exist

Table XI: Queuing Analysis (cont.)

ID	Intersection	Existing Queue Storage Length (ft.)		Existing		Existing plus Project		Near Term plus Project		Cumulative Year 2046 plus Project		
				AM	PM	AM	PM	AM	PM	AM	PM	
4	Road 72 / Avenue 412	Eastbound Left-Through	>500	52	54	51	44	43	45	*	*	
		Eastbound Left-Through-Right	*	*	*	*	*	*	*	*	51	45
		Westbound Left-Through	*	*	*	*	*	*	*	*	43	50
		Westbound Through	>500	43	46	41	46	40	47	*	*	
		Westbound Right	>300	66	55	45	57	64	72	59	69	
		Northbound Left-Through-Right	*	*	*	*	*	*	*	*	66	95
		Southbound Left-Through-Right	*	*	*	*	*	*	*	*	71	118
		Southbound Left-Right	>500	52	65	53	54	68	67	*	*	
5	Monte Vista Drive / Avenue 412	Eastbound Left-Through	>500	60	107	41	87	59	55	56	107	
		Westbound Through	>500	0	0	0	0	0	0	0	0	
		Westbound Right	>500	0	7	0	0	0	0	0	0	
		Southbound Left	>500	44	56	44	46	56	39	55	59	
		Southbound Right	100	45	44	33	54	42	57	54	60	

Note: * = Does not exist or is not projected to exist

Project’s Pro-Rata Fair Share of Future Transportation Improvements

The Project’s fair share percentage impact to the study intersection that currently operates below its LOS threshold, and which is not covered by an existing impact fee program, is provided in Table XII. The Project’s fair share percentage impacts were calculated using the Caltrans pro-rata fair share formula. The Project’s pro-rata fair shares were calculated utilizing the Existing, Project Only Trips and Cumulative Year 2046 plus Project volumes. Figure 2 illustrates the Existing traffic volumes, Figure 4 illustrates the Project Only Trips and Figure 8 illustrates the Cumulative Year 2046 plus Project traffic volumes. Since the critical peak period for the study facilities was determined to be during the PM peak period, the PM peak traffic volumes are utilized to determine the Project’s pro-rata fair share.

It is recommended that the Project contribute its equitable fair share as listed in Table XII for the improvements necessary to return the intersection to an acceptable LOS. However, fair share contributions should only be made for those facilities or portion thereof not funded by the responsible agencies roadway impact fee program(s) or grant funding, as appropriate. For those improvements not presently covered by local and regional roadway impact fee programs or grant funding, it is recommended that the Project contribute its equitable fair share. Payment of the Project’s equitable fair share in addition to the local and regional impact fee programs would satisfy the Project’s traffic cumulative traffic impacts.

Table XII: Project’s Fair Share of Future Roadway Improvements

<i>ID</i>	<i>Intersection</i>	<i>Existing Traffic Volumes (PM Peak)</i>	<i>Cumulative Year 2046 Traffic Volumes (PM Peak)</i>	<i>Project Only Trips (PM Peak)</i>	<i>Project Fair Share (%)</i>
1	Road 70 / Avenue 416	1,666	2,132	18	3.86
2	Road 72 / Avenue 416	1,958	2,903	35	3.70

Note: Project Fair Share = ((Project Only Trips) / (Cumulative Year 2046 plus Project Traffic Volumes – Existing Traffic Volumes)) X 100

Conclusions and Recommendations

Conclusions and recommendations regarding the proposed Project are presented below.

Existing Traffic Conditions

- At present, the study intersection of Road 70 at Avenue 416 exceeds its LOS threshold during the PM peak period. It is recommended that the following improvements be considered for implementation to improve the LOS at this intersection.
 - Road 70 / Avenue 416
 - Implement a raised median island along Avenue 416 to prevent left-turn and through movements from Road 70;
 - Modify the northbound left-through-right to a right-turn lane;
 - Modify the southbound left-through-right to a right-turn lane; and
 - Furthermore, traffic will need to be rerouted due to the proposed limited access at the intersection of Road 70 at Avenue 416. Traffic volumes at the intersection of Road 72 at Avenue 416, Road 70 at Avenue 412 and Road 72 at Avenue 412 will be altered. As a result, those intersections will appear in the improved Synchro reports. No additional modifications as a result of this shift in traffic patterns were necessary.
- At present, all study segments operate at an acceptable LOS.

Existing plus Project Traffic Conditions

- Access to and from the Project site will primarily be from two (2) proposed access points. The first access point will be located along the east side of Road 70 approximately 500 feet north of Avenue 412 and is proposed to be full access. The second access point will be located along the west side of Road 72 approximately 300 feet north of Avenue 412 and is also proposed to be full access.
- At buildout, the proposed Project is estimated to generate approximately 774 daily trips, 57 AM peak hour trips and 76 PM peak hour trips.
- It is recommended that the Project construct Class II Bikeways along its frontage to Road 72 and ADA compliant walkways along its frontages to Road 70, Road 72 and Avenue 412.
- Under this scenario, the intersection of Road 70 at Avenue 416 is projected to exceed its LOS threshold during the PM peak period. It is recommended that the following improvements be considered for implementation to improve the LOS at this intersection.
 - Road 70 / Avenue 416
 - Implement a raised median island along Avenue 416 to prevent left-turn and through movements from Road 70;
 - Modify the northbound left-through-right to a right-turn lane;
 - Modify the southbound left-through-right to a right-turn lane; and
 - Furthermore, traffic will need to be rerouted due to the proposed limited access at the intersection of Road 70 at Avenue 416. Traffic volumes at the intersection of Road 72 at Avenue 416, Road 70 at Avenue 412 and Road 72 at Avenue 412 will be altered. As a result, those intersections will appear in the improved Synchro reports. No additional modifications as a result of this shift in traffic patterns were necessary.
- Under this scenario, all study segments are projected to operate at an acceptable LOS.

Near Term plus Project Traffic Conditions

- The total trip generation for the Near Term Projects is 12,598 weekday daily trips, 1,849 weekday AM peak hour trips and 1,550 weekday PM peak hour trips.
- Under this scenario, the intersection of Road 70 at Avenue 416 is projected to exceed its LOS threshold during the PM peak period. It is recommended that the following improvements be considered for implementation to improve the LOS at this intersection.
 - Road 70 / Avenue 416
 - Implement a raised median island along Avenue 416 to prevent left-turn and through movements from Road 70;
 - Modify the northbound left-through-right to a right-turn lane;
 - Modify the southbound left-through-right to a right-turn lane; and
 - Furthermore, traffic will need to be rerouted due to the proposed limited access at the intersection of Road 70 at Avenue 416. Traffic volumes at the intersection of Road 72 at Avenue 416, Road 70 at Avenue 412 and Road 72 at Avenue 412 will be altered. As a result, those intersections will appear in the improved Synchro reports. No additional modifications as a result of this shift in traffic patterns were necessary.
- Under this scenario, all study segments are projected to operate at an acceptable LOS.

Cumulative Year 2046 plus Project Traffic Conditions

- Under this scenario, the intersections of Road 70 at Avenue 416 and Road 72 at Avenue 416 are projected to exceed their LOS thresholds during one or both peak periods. It is recommended that the following improvements be considered for implementation to improve the LOS at this intersection.
 - Road 70 / Avenue 416
 - Implement a raised median island along Avenue 416 to prevent left-turn and through movements from Road 70;
 - Modify the northbound left-through-right to a right-turn lane;
 - Modify the southbound left-through-right to a right-turn lane; and
 - Furthermore, traffic will need to be rerouted due to the proposed limited access at the intersection of Road 70 at Avenue 416. Traffic volumes at the intersection of Road 72 at Avenue 416, Road 70 at Avenue 412 and Road 72 at Avenue 412 will be altered. As a result, those intersections will appear in the improved Synchro reports. No additional modifications as a result of this shift in traffic patterns were necessary.
 - Road 72 / Avenue 416
 - Add northbound right-turn lane;
 - Modify the northbound through-right to a through lane; and
 - Modify the traffic signal to accommodate the added lanes.
- Under this scenario, all study segments are projected to operate at an acceptable LOS.

Queuing Analysis

- It is recommended that the City consider left-turn and right-turn lane storage lengths as indicated in the Queuing Analysis.

Project's Equitable Fair Share

- It is recommended that the Project contribute its equitable Fair Share as presented in Table XII for those future improvements which are not covered by an existing impact fee program or grant funds.

Study Participants

JLB Traffic Engineering, Inc. Personnel:

Jose Luis Benavides, PE, TE	Project Manager
Matthew Arndt, EIT	Engineer I/II
Christian Sanchez, EIT	Engineer I/II
Javier Rios	Engineer I/II
Adrian Benavides	Engineering Aide
Carlos Topete	Engineering Aide
Arjun Dhillon	Engineering Aide

Persons Consulted:

Andres Castrejon	Land Design Consulting
Jose Lemus	Land Design Consulting
Juan Luis Carranco	Land Design Consulting
Jason Watts	City of Dinuba
Emma Laplante	City of Dinuba
Gary Mills	County of Tulare
David Deel	Caltrans, D6
Kasia Poleszczuk	TCAG
Roberto Brady	TCAG

References

- Caltrans. 2019. "Highway Design Manual". Sacramento: State of California.
- Caltrans. 2020. "Vehicle Miles Traveled-Focused Transportation Impact Study Guide". Sacramento: State of California.
- Caltrans. 2024. "California Manual on Uniform Traffic Control Devices". Sacramento: State of California.
- City of Dinuba. 2006. "General Plan Update Background Report". Dinuba: City of Dinuba.
- City of Dinuba. 2008. "General Plan Policies Statement". Dinuba: City of Dinuba.
- County of Tulare. 2012. "2020 Update Tulare County General Plan". Visalia: Tulare County.
- Cubic ITS, Inc. 2019. "Synchro Studio 11 User Guide". Sugar Land: Trafficware, LLC.
- Institute of Transportation Engineers. 2017. "Trip Generation Manual". Washington: Institute of Transportation Engineers.
- National Academies of Sciences, Engineering, and Medicine. 2022. "Highway Capacity Manual 7th Edition: A Guide for Multimodal Mobility Analysis" Washington: The National Academies Press.
- Transportation Research Board. 2016. "Highway Capacity Manual". Washington: The National Academy of Sciences.

Draft Vehicle Miles Traveled Analysis

Empire Estates

Located on the Northwest Corner of Avenue 412
and Road 72

In the City of Dinuba, California

Prepared for:

Jose Lemus, PE
6702 North Cedar Avenue, Suite #201
Fresno, CA 93710

March 1, 2024

Project No. 029-005



Traffic Engineering, Transportation Planning, & Parking Solutions

516 W. Shaw Ave., Ste. 103

Fresno, CA 93704

Phone: (559) 570-8991

www.JLBtraffic.com



Traffic Engineering, Transportation Planning, & Parking Solutions

Draft Vehicle Miles Traveled Analysis

For the Empire Estates located on the Northwest Corner of Avenue 412 and Road 72

In the City of Dinuba, CA

March 1, 2024

This Draft Vehicle Miles Traveled Analysis has been prepared under the direction of a licensed Traffic Engineer. The licensed Traffic Engineer attests to the technical information contained therein and has judged the qualifications of any technical specialists providing engineering data from which recommendations, conclusions and decisions are based.

Prepared by:

Jose Luis Benavides, P.E., T.E.

President



Traffic Engineering, Transportation Planning, & Parking Solutions

516 W. Shaw Ave., Ste. 103
Fresno, CA 93704
Phone: (559) 570-8991
www.JLBtraffic.com

Table of Contents

Plan Description	1
Regulatory Setting, Criteria of Significance and Methodology	1
Regulatory Setting.....	1
Criteria of Significance	2
VMT Calculations	2
VMT Output	2
Conclusions	2
Study Participants	3
References	4

List of Tables

Table I: VMT Output	2
----------------------------------	----------

List of Appendices

Appendix A: Site Plan

Appendix B: VMT Output

Plan Description

This Draft Report describes a **Vehicle Miles Traveled (VMT) Analysis** prepared by **JLB Traffic Engineering, Inc.** (JLB) for Empire Estates (**Project**) to be located on the northwest corner of Avenue 412 and Road 72. The Project proposes to develop 75 dwelling units of single family detached housing. Based on information provided by JLB, the Project is consistent with the City of Dinuba *General Plan Policies Statement*. A Project Site Plan is shown in Exhibit A.

Regulatory Setting, Criteria of Significance and Methodology

Regulatory Setting

Senate Bill (SB) 743 requires that relevant CEQA analysis of transportation impacts be conducted using a metric known as VMT instead of Level of Service (LOS). VMT measures how much actual auto travel (additional miles driven) a proposed project would create on California roads. If the project adds excessive car travel onto the roads, the project may cause a significant transportation impact.

The State CEQA Guidelines were amended to implement SB 743, by adding Section 15064.3. Among its provisions, Section 15064.3 confirms that, except with respect to transportation projects, a project's effect on automobile delay shall not constitute a significant environmental impact. Therefore, LOS measures of impacts on traffic facilities are no longer a relevant CEQA criteria for transportation impacts.

CEQA Guidelines Section 15064.3(b)(4) states that "[a] lead agency has discretion to evaluate a project's vehicle miles traveled, including whether to express the change in absolute terms, per capita, per household or in any other measure. A lead agency may use models to estimate a project's vehicle miles traveled, and may revise those estimates to reflect professional judgment based on substantial evidence. Any assumptions used to estimate vehicle miles traveled and any revision to model outputs should be documented and explained in the environmental document prepared for the project. The standard of adequacy in Section 15151 shall apply to the analysis described in this section."

The City of Dinuba has not yet adopted its own official VMT guidelines but uses the County of Tulare's *SB 743 Guidelines*, referred to in this document as the County of Tulare's VMT Guidelines. The County of Tulare's VMT Guidelines were published on June 8, 2020 and are consistent with the requirements of CEQA Guidelines Sections 15064.3 and 15064.7. The December 2018 Technical Advisory on Evaluating Transportation Impacts in CEQA (Technical Advisory) published by the Governor's Office of Planning and Research (OPR), was utilized as a reference and guidance document in the preparation of the County of Tulare's VMT Guidelines.

Criteria of Significance

The County of Tulare’s VMT Guidelines adopted a screening standard and criteria that can be used to screen out qualified projects that meet the adopted criteria from needing to prepare a detailed VMT analysis. These criteria may be size, location, proximity to transit, of trip making potential. In general development projects that are consistent with the City's General Plan and Zoning and that meet one or more of the following criteria can be screened out from a quantitative VMT analysis.

1. Small Projects (Less than 500 average daily trips)
2. Local-serving Retail and Similar Land Uses
3. Local-Serving Public Facilities
4. Affordable and Farmworker Housing Projects
5. Redevelopment Projects that Result in a Net Reduction of VMT
6. Mixed-Use Projects that Result in a Net Reduction of VMT

For Projects that are not screened out, a quantitative analysis of VMT impacts must be prepared and compared against the adopted VMT threshold of significance. This Project does not meet any of the screening criteria and a quantitative VMT analysis will be conducted. The County of Tulare’s VMT Guidelines document includes thresholds of significance for land development projects, update of the general plan or community plans and transportation projects. These thresholds were developed using the County of Tulare as the applicable region. Residential projects have a significant transportation impact when the VMT per capita equals or exceeds the average VMT per capita for the TAZ in which the project is located. Office projects have a significant transportation impact when the VMT per employee equals or exceeds the average VMT per employee for the TAZ in which the project is located. Regional retail projects have a significant transportation impact when the project results in a net increase in VMT. Industrial projects have a significant transportation impact when the VMT per employee exceeds the average VMT per employee for the TAZ in which the project is located.

VMT Calculations

VMT Output

The TAZ in which the Project is located was determined to be TAZ 2777. Table I displays the VMT per capita for the TAZ in which the Project is located as well as the VMT per capita for the Project. The data for TAZ 2777 is stated in the County of Tulare VMT Guidelines while the Project VMT was output from the Tulare County Association of Governments (TCAG) regional model. As can be seen in Table I, the Project VMT per capita is lower than the VMT per capita in the TAZ in which the Project is located. As a result, the Project results in a less than significant VMT impact.

Table I: VMT Output

VMT Measurement	TAZ 2777 VMT Results ¹	Project (TAZ 193) VMT Results ¹	Significant VMT Impact?
VMT per Capita	10.70	8.50	No

Note: 1 = VMT Results from TCAG Model

Conclusions

- The TAZ in which the Project is located, TAZ 2777, has a VMT per capita of 10.7.
- TCAG analyzed the Project and output a VMT per capita of 8.5.
- As the Project has a VMT per capita that is less than the VMT per capita of the TAZ in which it is located, the Project was determined to have less than significant VMT impacts.



Study Participants

JLB Traffic Engineering, Inc. Personnel

Jose Luis Benavides, PE, TE	Project Manager
Matthew Arndt, EIT	Engineer I/II
Christian Sanchez	Engineer I/II
Adrian Benavides	Engineering Aide
Carlos Topete	Engineering Aide

Persons Consulted:

Jose Lemus	Land Design Consulting
Andres Castrejon	Land Design Consulting
Juan Luis Carranco	Land Design Consulting
Jason Watts	City of Dinuba
Gary Mills	County of Tulare
David Deel	Caltrans
Kasia Poleszczuk	Tulare County Association of Governments
Roberto Brady	Tulare County Association of Governments
Steven Ingoldsby	Tulare County Association of Governments

References

- California Air Pollution Officers Association. 2021. "Handbook for Analyzing Greenhouse Gas Emission Reductions, Assessing Climate Vulnerabilities, and Advancing Health and Equity.". Sacramento: State of California.
- Caltrans. 2020. "Vehicle Miles Traveled-Focused Transportation Impact Study Guide". Sacramento: State of California.
- Caltrans. 2021. "California Manual on Uniform Traffic Control Devices". Sacramento: State of California.
- City of Dinuba. 2008. "General Plan Policies Statement". Dinuba: City of Dinuba.
- Tulare County. 2012. "Tulare County General Plan – 2030 Update". Tulare: Tulare County.
- Tulare County. 2020. "County of Tulare SB 743 Guidelines". Tulare: Tulare County.
- Governor's Office of Planning and Research. 2018. Technical Advisory On Evaluating Transportation Impacts In CEQA. Ebook. Sacramento: State of California, pp.1-34.
- Institute of Transportation Engineers. 2017. "Trip Generation Manual". Washington: Institute of Transportation Engineers.

Appendix A: Site Plan



www.JLBtraffic.com
info@JLBtraffic.com

516 W. Shaw Ave., Ste. 103
Fresno, CA 93704
(559) 570-8991

App | A

TENTATIVE SUBDIVISION MAP EMPIRE ESTATES

A VESTING MAP

A SINGLE-FAMILY RESIDENTIAL SUBDIVISION
IN THE CITY OF DINUBA,
TULARE COUNTY, CALIFORNIA

APN: 012-290-011-000
GROSS AREA: 18.59 ACRES MORE LESS
NET AREA: 16.35 ACRES MORE LESS

APN: 012-290-010-000
LOT 12 OF ALTA COLONY PER RECORD MAP
VOLUME 2 PAGE 97.

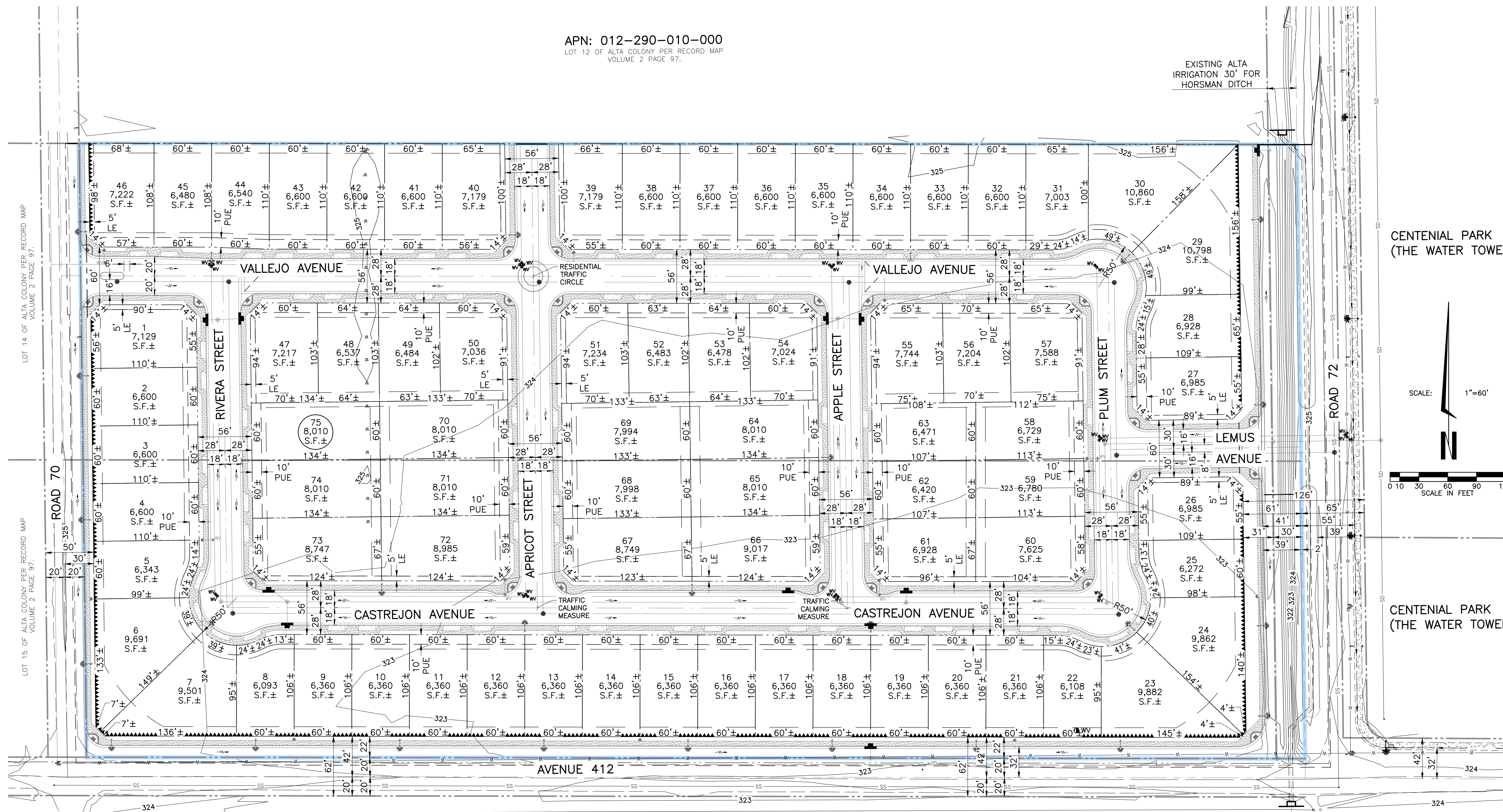

CENTENIAL PARK
(THE WATER TOWER)

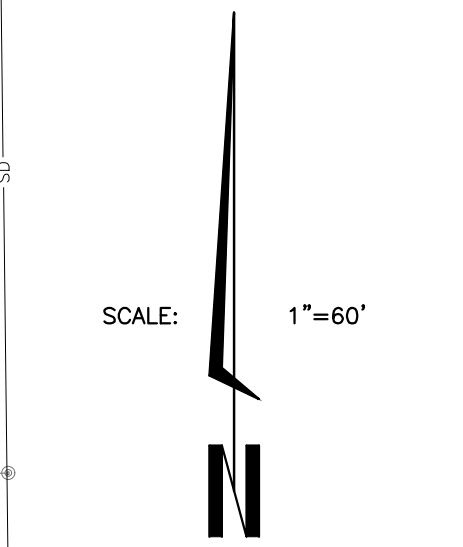

CENTENIAL PARK
(THE WATER TOWER)

LEGAL DESCRIPTION

THE LAND REFERRED TO HEREIN BELOW IS SITUATED IN THE UNINCORPORATED AREA IN COUNTY OF TULARE, STATE OF CALIFORNIA AND IS DESCRIBED AS FOLLOWS:

LOTS 13 AND 16 OF ALTA COLONY, IN THE COUNTY OF TULARE, STATE OF CALIFORNIA, ACCORDING TO THE MAP THEREOF RECORDED IN BOOK 2, PAGE 97 OF MAPS, TULARE COUNTY RECORDS.

IMPROVEMENTS TO BE INSTALLED

- STREETS - CITY OF DINUBA STANDARDS
- WATER - CITY OF DINUBA STANDARDS
- SEWER - CITY OF DINUBA STANDARDS
- IRRIGATION - ALTA IRRIGATION STANDARDS
- CURB & GUTTER - CITY OF DINUBA STANDARDS
- MASONRY BLOCK WALL - CITY OF DINUBA STANDARDS
- 6" WOOD FENCE - CEDAR INCENSE
- SIDEWALK - CITY OF DINUBA STANDARDS
- DRAINAGE - CITY OF DINUBA STANDARDS
- STREET LIGHTS - CITY OF DINUBA STANDARDS
- GAS & ELECTRICITY - PACIFIC GAS & ELECTRIC
- TELEPHONE - AT&T
- CABLEVISION - COMCAST

SITE ADDRESS

APN: 012-290-011-000
41232 ROAD 70, DINUBA, CA. 93618

LEGEND

- | | | | |
|-----|--|---|--------------------------------------|
| --- | EXISTING PROPERTY LINE | ○ | EXISTING SANITARY SEWER MANHOLE |
| --- | PROPOSED PROPERTY LINE | ○ | EXISTING STORM DRAIN MANHOLE |
| --- | PROPOSED PUBLIC UTILITY EASEMENT | ○ | EXISTING POWER POLE |
| --- | PROPOSED LANDSCAPE EASEMENT | ○ | EXISTING STANDPIPE |
| --- | LIMITS OF THE SUBDIVISION | ○ | EXISTING IRRIGATION VALVE |
| --- | EXISTING STORM DRAIN | ○ | EXISTING WATER VALVE |
| --- | EXISTING SANITARY SEWER | ○ | EXISTING FIRE HYDRANT |
| --- | EXISTING WATER MAIN | ○ | EXISTING STREETLIGHT |
| --- | PROPOSED SANITARY SEWER | ○ | PROPOSED FIRE HYDRANT |
| --- | PROPOSED WATER MAIN | ○ | PROPOSED WATER VALVE |
| --- | PROPOSED STORM DRAIN | ○ | PROPOSED STORM DRAIN INLET |
| --- | PROPOSED IRRIGATION | ○ | INDICATES STORM WATER FLOW DIRECTION |
| --- | PROPOSED LANDSCAPE SLEEVE | ○ | PROPOSED STORM DRAIN MANHOLE |
| --- | PROPOSED SAWCUT | ○ | PROPOSED SANITARY SEWER MANHOLE |
| --- | APPROXIMATE CITY LIMITS LOCATION | ○ | PROPOSED STREETLIGHT |
| --- | PROPOSED SIDEWALK | ○ | |
| --- | PROPOSED CURB AND GUTTER | ○ | |
| --- | EXISTING EDGE OF PAVEMENT | ○ | |
| --- | EXISTING CURB AND GUTTER | ○ | |
| --- | INDICATES RELINQUISHMENT OF DIRECT ACCESS RIGHTS | ○ | |

GENERAL NOTES:

- SITE:
NUMBER OF LOTS - 75
AVERAGE LOT SIZE - 7227 SF
MINIMUM LOT SIZE - 6093 SF
- EXISTING FACILITIES: NONE WILL REMAIN.
- EXISTING HOME NEAR THE SOUTHWEST CORNER OF PROPERTY TO BE DEMOLISHED.
- EXISTING IRRIGATION CANAL ON EASTERLY PORTION OF PROPERTY TO BE PIPED AND UNDERGROUND.
- RAILROADS: N/A.
- EXISTING LAND USE: VACANT
- PROPOSED LAND USE: SINGLE FAMILY RESIDENTIAL
- EXISTING ZONING: R-1-7.5, MEDIUM LOW DENSITY RESIDENTIAL (7,500 SF MIN. LOT)
- PROPOSED ZONING: R-1-8, MEDIUM DENSITY RESIDENTIAL (6,000 SF MIN. LOT)
- WET UTILITIES: PROPOSED SEWER & WATER SOURCES TO BE A PART OF CITY OF DINUBA, PER CITY OF DINUBA STANDARDS. STORM DRAIN SOURCE PER CITY OF DINUBA MASTER PLAN, TO DRAIN TO CENTENIAL PARK (THE WATER TOWER).
- DRY UTILITIES: TO BE UNDERGROUND.

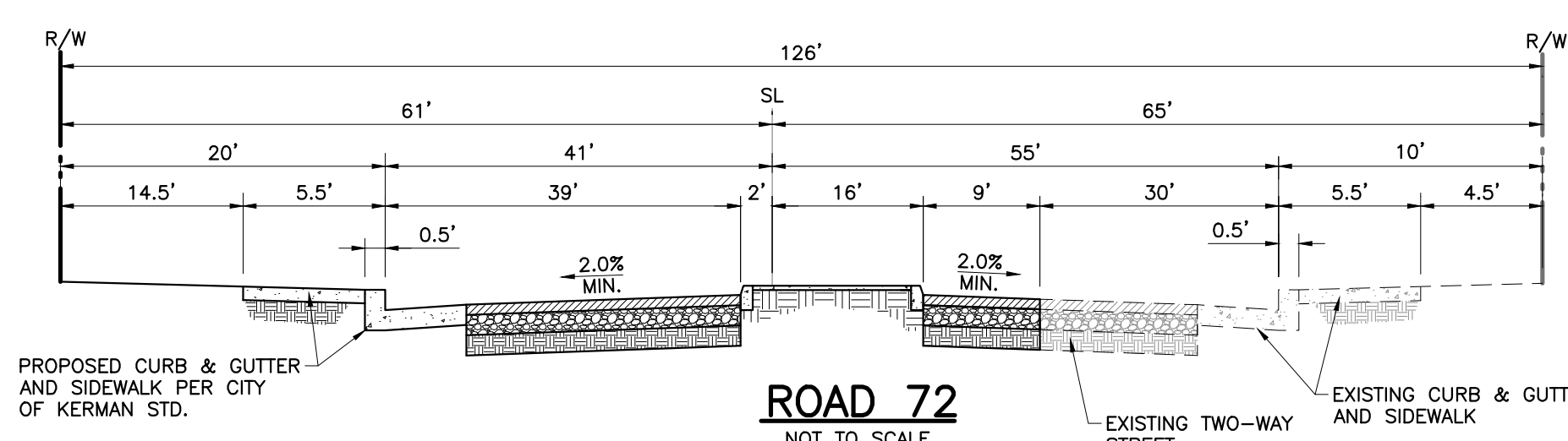
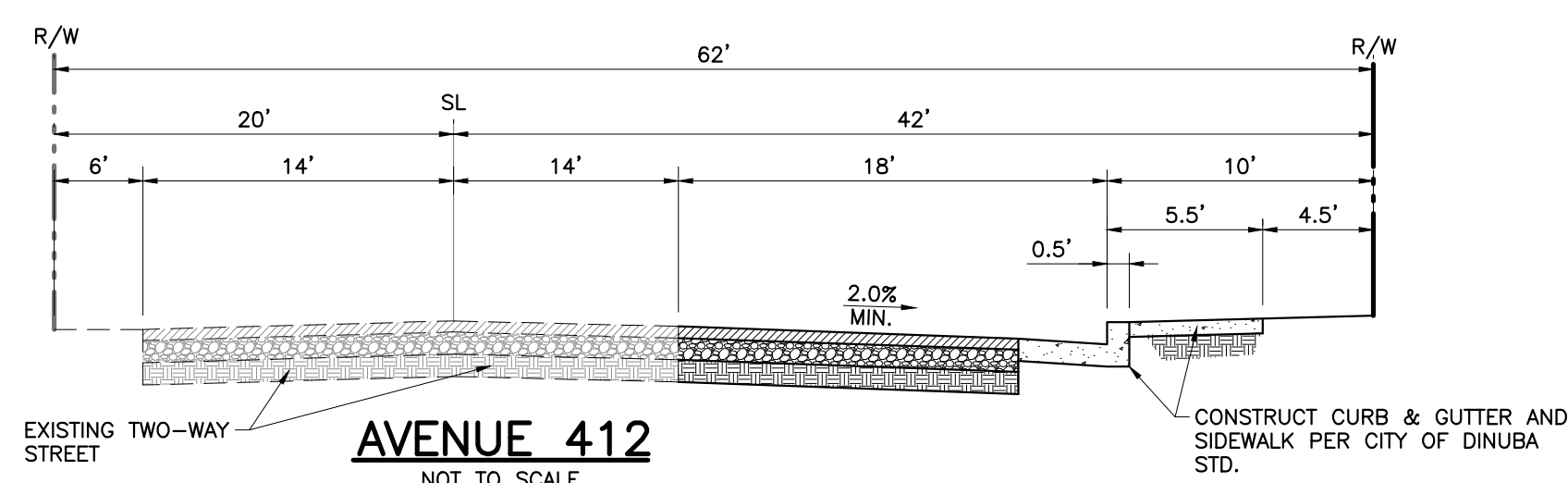
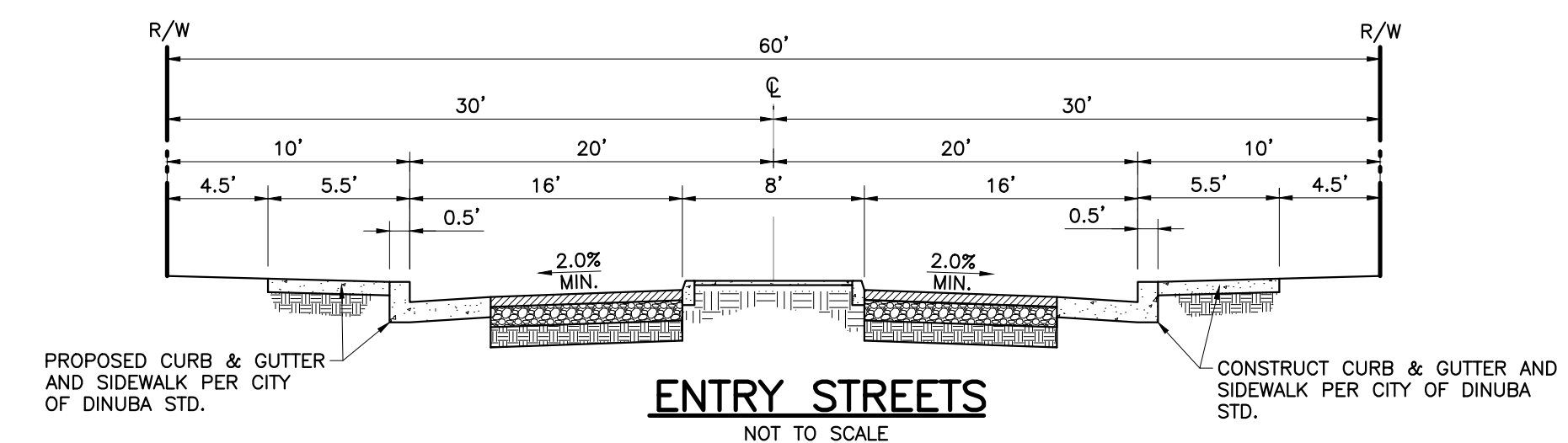
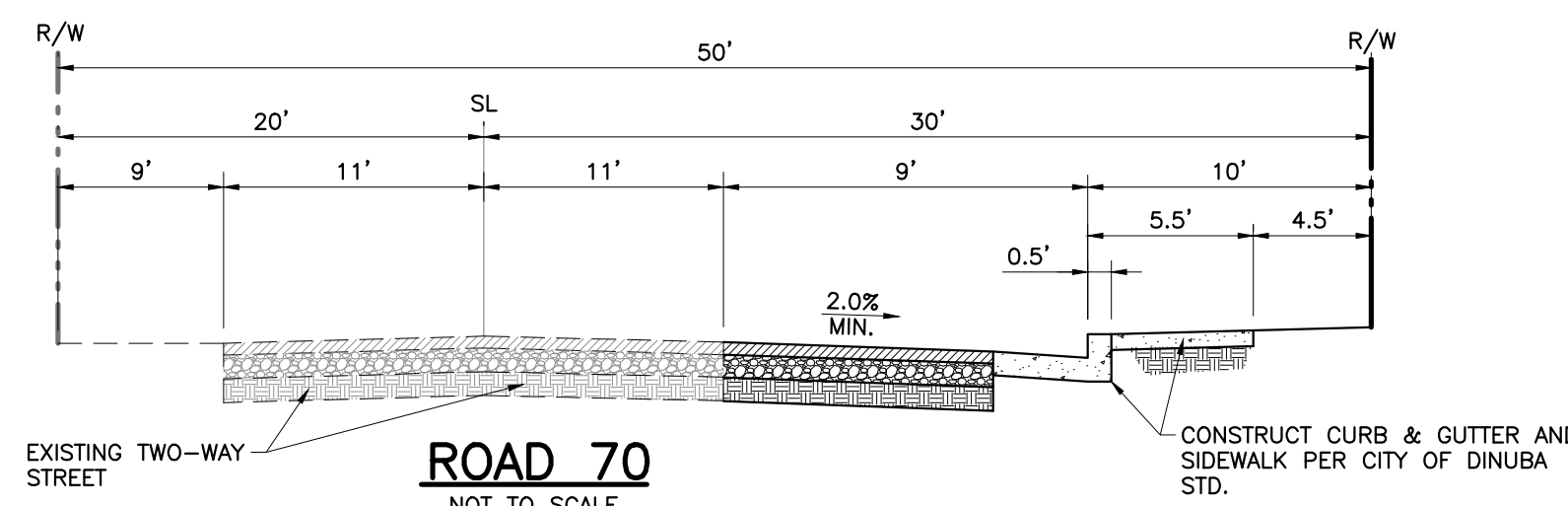
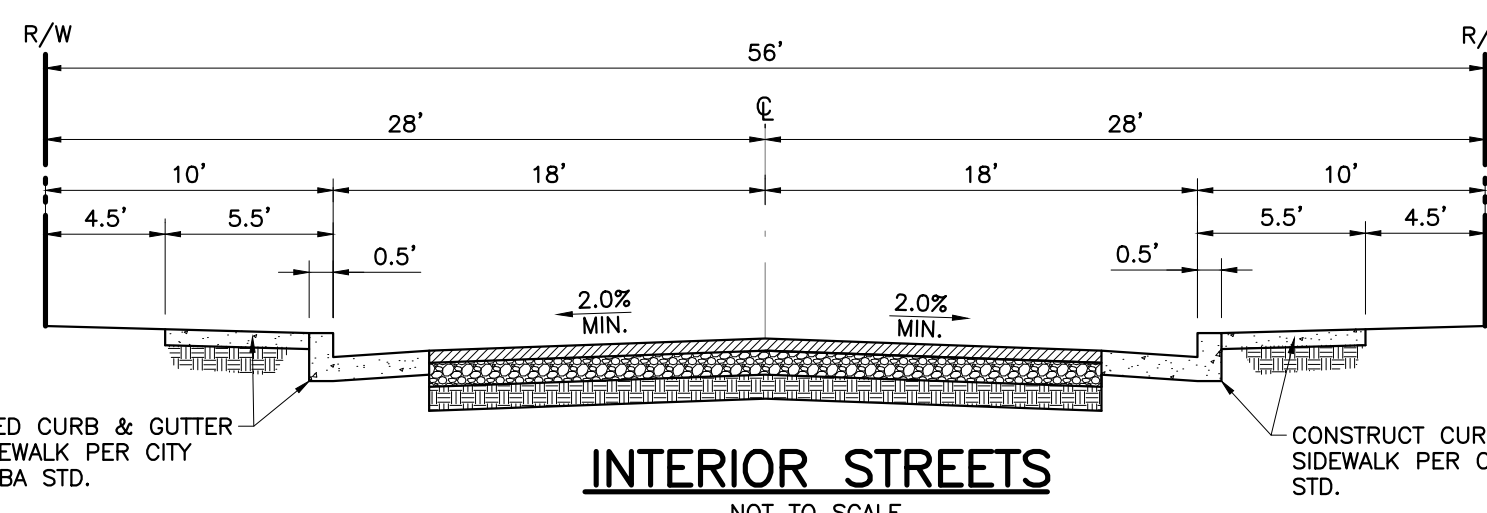

REVISION

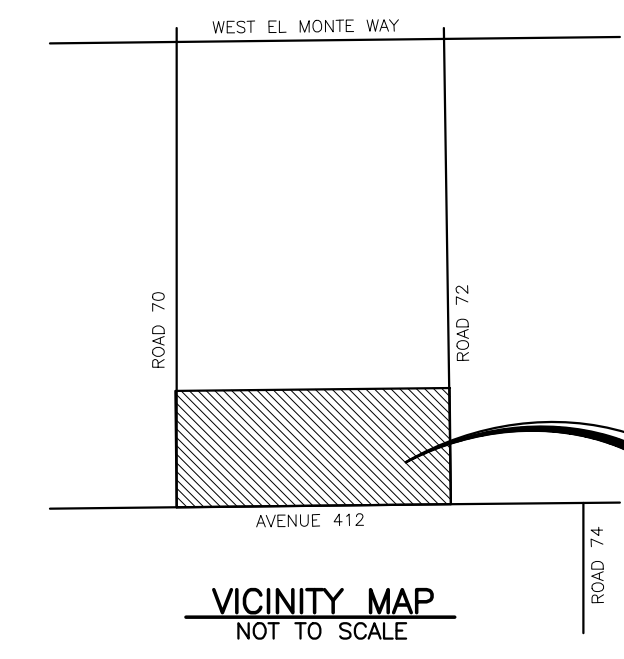

PROJECT SITE

OWNERS:
SUSAN HIRATA AND EDWIN K. HIRATA
41232 ROAD 70,
DINUBA, CA. 93612

PREPARED BY:
JOSE LEMUS, RCE NO. 80458
PREPARED: 11/03/2023

LANDDESIGN
CONSULTING
"Building a World"

6702 N. CEDAR AVE. SUITE 201 FRESNO, CA 93710
TEL (559) 538-3402

Appendix B: TCAG VMT Output



www.JLBtraffic.com
info@JLBtraffic.com

516 W. Shaw Ave., Ste. 103
Fresno, CA 93704
(559) 570-8991

App | B

Matt Arndt

From: Kasia A Poleszczuk <KPoleszczuk@tularecag.ca.gov>
Sent: Tuesday, December 19, 2023 3:02 PM
To: Matt Arndt
Cc: Roberto Brady
Subject: Empire Estates _ VMT per Capita

Hi,

Here you go. Per your request:

County of Tulare Guidance		
2023 Base VMT Thresholds		VMT/per capita
	2010 CSTDM Zone 2777	10.70
	Empire Estates _ Zone 193	8.5

From: Matt Arndt <marndt@jlbtraffic.com>
Sent: Tuesday, December 19, 2023 2:19 PM
To: Kasia A Poleszczuk <KPoleszczuk@tularecag.ca.gov>
Subject: RE: Empire Estates _ VMT question

This Message Is From an External Sender

This message came from outside your organization.

Hello,

Can you give me the Project's VMT per Capita?

Sincerely,

Matthew Arndt